



# RV DN 10÷100

PVC-U

Sediment strainer



# RV DN 10÷100

The RV Sediment strainer limits the passage of any solid particles present in the fluid by means of a strainer.

## SEDIMENT STRAINER

- Connection system for solvent weld, threaded and flanged joints
- **Strainer** mounted on an easily removed **support** that facilitates the cleaning or replacement
- **Valve material compatibility** (PVC-U) with water conveyance, drinking water and other food substances according to **current regulations**
- Can be maintained with the valve body installed

Technical specifications	
<b>Construction</b>	Sediment strainer
<b>Size range</b>	DN 15 ÷ 50
<b>Nominal pressure</b>	<p><b>PVC-U Grey</b>  <b>DN 10÷50:</b> PN 16 with water at 20 °C  <b>DN 65:</b> PN 10 with water at 20 °C  <b>DN 80÷100:</b> PN 6 with water at 20 °C</p> <p><b>PVC-U Transparent</b>  <b>DN 10÷25:</b> PN 16 with water at 20 °C  <b>DN 32÷50:</b> PN 10 with water at 20 °C  <b>DN 65:</b> PN 6 with water at 20 °C  <b>DN 80÷100:</b> PN 4 with water at 20 °C</p>
<b>Temperature range</b>	0 °C ÷ 60 °C
<b>Coupling standards</b>	<p><b>Solvent welding:</b> EN ISO 1452, EN ISO 15493, BS 43461, DIN 8063, NF T54-028, ASTM D 2467, JIS K 6743. Can be coupled to pipes according to EN ISO 1452, EN ISO 15493, DIN 8062, NF T54-016, ASTM D 1785, JIS K 6741</p> <p><b>Thread:</b> UNI ISO 228-1, DIN 2999, ASTM D 2467, JIS B 0203</p> <p><b>Flanging system:</b> ISO 7005-1, EN ISO 1452, EN ISO 15493, EN 558-1 (DN 10÷50), DIN 2501, ANSI B.16.5 cl.150, JIS B 2220</p>
<b>Reference standards</b>	<p><b>Construction criteria:</b> EN ISO 1452, EN ISO 15493</p> <p><b>Test methods and requirements:</b> ISO 9393</p> <p><b>Installation criteria:</b> DVS 2204, DVS 2221, UNI 11242</p>
<b>Valve material</b>	<p><b>Body:</b> PVC-U grey or transparent</p> <p><b>Strainer:</b> PVC-U or STAINLESS steel</p>
<b>Seal material</b>	EPDM, FKM

# TECHNICAL DATA

## PRESSURE VARIATION ACCORDING TO TEMPERATURE

For water and non-hazardous fluids with regard to which the material is classified as CHEMICALLY RESISTANT. In other cases, a reduction of the nominal pressure PN is required (25 years with safety factor).

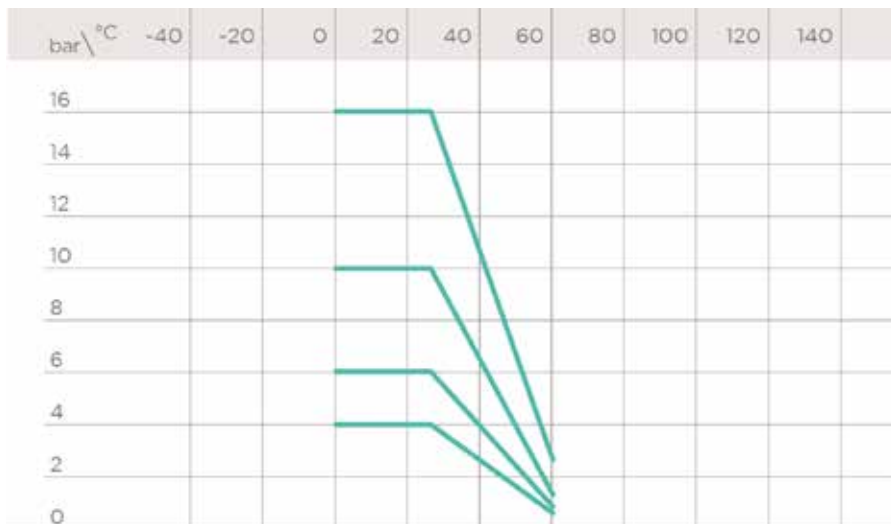

## PRESSURE DROP GRAPH

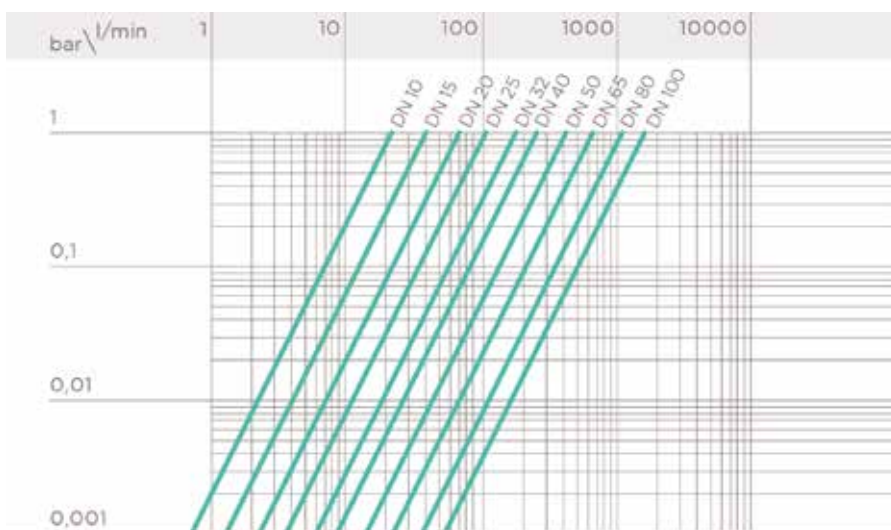

## K<sub>v</sub>100 FLOW COEFFICIENT

The K<sub>v</sub>100 flow coefficient is the Q flow rate of litres per minute of water at a temperature of 20°C that will generate Δp= 1 bar pressure drop at a certain valve position. The Kv100 values shown in the table are calculated with the valve completely clean.

DN	10	15	20	25	32	40	50	65	80	100
Kv100 l/min	22	40	70	103	188	255	410	650	1050	1700

## STRAINER DIMENSIONS

Pitch (mm)	0,7	1,0	1,5	2,0	2,5
number of holes per cm <sup>2</sup>	260	125	67	36	26
ASTM series equivalent in strainer	45	70	40	35	30
ø equivalent hole μm	370	200	420	550	580
strainer material	STAINLESS STEEL	PVC-U	PVC-U	PVC-U	PVC-U

## TOTAL STRAINER AREA A<sub>TOT</sub> (CM<sup>2</sup>)

DN	10	15	20	25	32	40	50	65	80	100
A <sub>tot</sub>	16	16	23,5	36	53	69	101	197	247	396

The information in this leaflet is provided in good faith. No liability will be accepted concerning technical data that is not directly covered by recognised international standards. FIP reserves the right to carry out any modification. Products must be installed and maintained by qualified personnel.

# DIMENSIONS

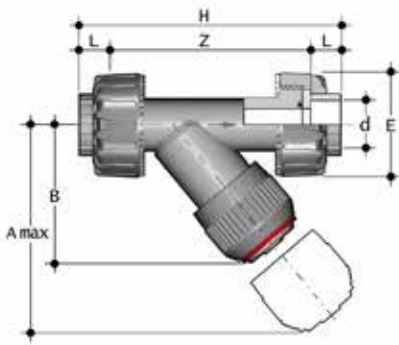

## RVUIV-RVUIT

RVUIV PVC-U rigid - RVUIT PVC-U transparent  
Sediment strainer with female union ends for solvent welding

d	DN	PN RVUIV	PN RVUIT	A max	B	E	H	L	Z	Fig.	g	RVUIV EPDM code	RVUIT EPDM code
16	10	16	16	125	72	55	135	14	107	A	203	RVUIV016E	RVUIT016E
20	15	16	16	125	72	55	135	16	103	A	211	RVUIV020E	RVUIT020E
25	20	16	16	145	84	66	158	19	120	A	358	RVUIV025E	RVUIT025E
32	25	16	16	165	95	75	176	22	132	A	526	RVUIV032E	RVUIT032E
40	32	16	10	190	111	87	207	26	155	A	733	RVUIV040E	RVUIT040E
50	40	16	10	210	120	100	243	31	181	A	1095	RVUIV050E	RVUIT050E
63	50	16	10	240	139	120	298	38	222	A	1843	RVUIV063E	RVUIT063E

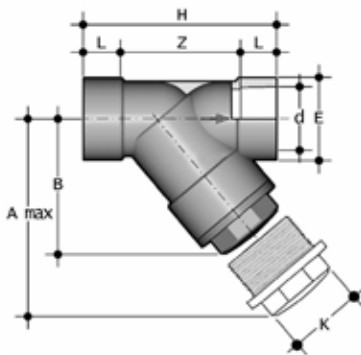

## RVIV-RVIT

RVIV PVC-U rigid - RVIT PVC-U transparent  
Sediment strainer with female ends for solvent welding

d	DN	PN RVIV	PN RVIT	A max	B	E	H	K	L	Z	Fig.	g	RVIV EPDM code	RVIT EPDM code
75	65	10	6	300	179	104	243	96	33	155	B	2385	RVIV075E	RVIT075E
90	80	6	4	325	192	116	262	105	37	160	B	2975	RVIV090E	RVIT090E
110	100	6	4	385	231	138	325	-	61	203	C	4610	RVIV110E	RVIT110E

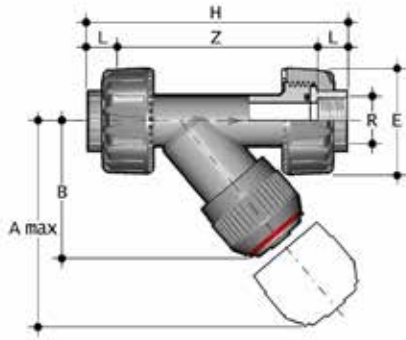

## RVUFV-RVUFT

RVUFV PVC-U rigid - RVUFT PVC-U transparent  
Sediment strainer with BSP threaded female union ends

R	DN	PN RVUFV	PN RVUFT	A max	B	E	H	L	Z	Fig.	g	RVUFV EPDM code	RVUFT EPDM code
3/8"	10	16	16	125	72	55	135	11,4	112,2	A	206	RVUFV038E	RVUFT038E
1/2"	15	16	16	125	72	55	142	15	112	A	210	RVUFV012E	RVUFT012E
3/4"	20	16	16	145	84	66	159	16,3	126,4	A	355	RVUFV034E	RVUFT034E
1"	25	16	16	165	95	75	183	19,1	144,8	A	522	RVUFV100E	RVUFT100E
1" 1/4	32	16	10	190	111	87	214	21,4	171,2	A	742	RVUFV114E	RVUFT114E
1" 1/2	40	16	10	210	120	100	235	21,4	192,2	A	1106	RVUFV112E	RVUFT112E
2"	50	16	10	240	139	120	285	25,7	233,6	A	1873	RVUFV200E	RVUFT200E

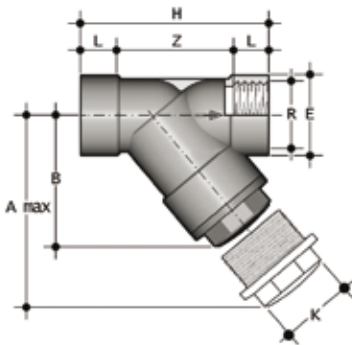

## RVFV-RVFT

RVFV PVC-U rigid - RVFT PVC-U transparent  
Sediment strainer with BSP threaded female ends

R	DN	PN RVFV	PN RVFT	A max	B	E	H	K	L	Z	Fig.	g	RVFV EPDM code	RVFT EPDM code
2" 1/2	65	10	6	300	179	104	243	96	30,2	182,6	B	2385	RVFV212E	RVFT212E
3"	80	6	4	325	192	116	262	105	33,3	195,4	B	2965	RVFV300E	RVFT300E
4"	100	6	4	385	231	138	325	-	39,3	246,4	C	4405	RVFV400E	RVFT400E

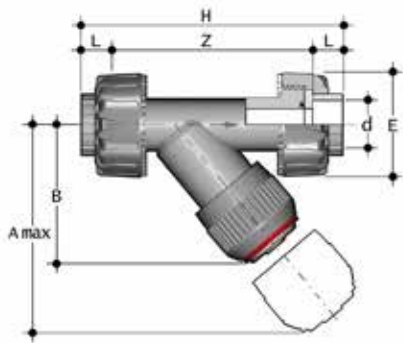

### RVUAT

PVC-U transparent  
Sediment strainer with female union ends for solvent welding, series ASTM

d	DN	PN	A max	B	E	H	L	Z	Fig.	g	EPDM code
3/8"	10	16	125	72	55	149	19,5	110	A	203	RVUAT038E
1/2"	15	16	125	72	55	149	22,5	104	A	211	RVUAT012E
3/4"	20	16	145	84	66	172	25,5	121	A	358	RVUAT034E
1"	25	16	165	95	75	190	28,7	132,6	A	526	RVUAT100E
1" 1/4	32	10	190	111	87	223	32	159	A	733	RVUAT114E
1" 1/2	40	10	210	120	100	251	35	181	A	1095	RVUAT112E
2"	50	10	240	139	120	298	38,2	221,6	A	1843	RVUAT200E

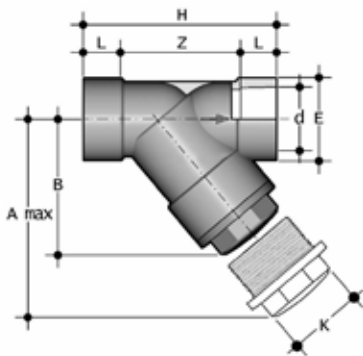

### RVAT

PVC-U transparent  
Sediment strainer with female ends for solvent welding, series ASTM

d	DN	PN	A max	B	E	H	K	L	Z	Fig.	g	EPDM code
3"	80	4	325	192	116	262	105	47,6	166,8	B	2975	RVAT300E
4"	100	4	385	231	138	325	-	57,2	210,6	C	4610	RVAT400E

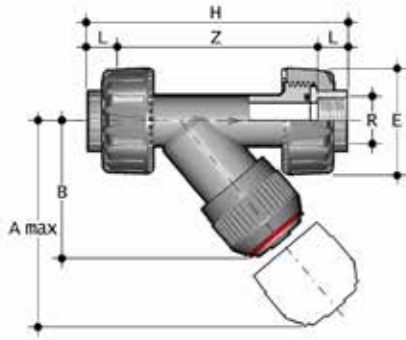

### RVUNT

PVC-U transparent  
Sediment strainer with NPT threaded female union ends

R	DN	PN	A max	B	E	H	L	Z	Fig.	g	EPDM code
3/8"	10	16	125	72	55	135	13,7	107,6	A	206	RVUNT038E
1/2"	15	16	125	72	55	142	17,8	106,4	A	210	RVUNT012E
3/4"	20	16	145	84	66	159	18	123	A	355	RVUNT034E
1"	25	16	165	95	75	183	22,6	137,8	A	522	RVUNT100E
1" 1/4	32	10	190	111	87	214	25,1	163,8	A	742	RVUNT114E
1" 1/2	40	10	210	120	100	235	24,7	185,6	A	1106	RVUNT112E
2"	50	10	240	139	120	285	29,6	225,8	A	1873	RVUNT200E

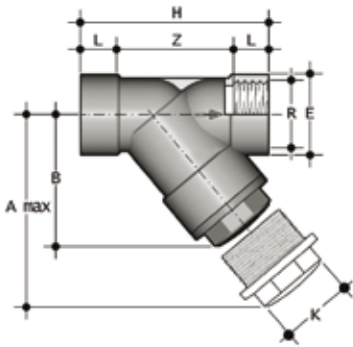

### RVNT

PVC-U transparent  
Sediment strainer with NPT threaded female ends

R	DN	PN	A max	B	E	H	K	L	Z	Fig.	g	EPDM code
3"	80	4	325	192	116	262	105	51	160	B	2965	RVNT300E
4"	100	4	385	231	138	325	-	61	203	C	4405	RVNT400E



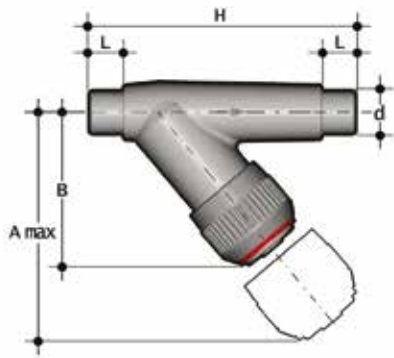

## RVDV-RVDT

RVDV PVC-U rigid - RVDT PVC-U transparent  
Sediment strainer with male ends for solvent welding

d	DN	PN RVDV	PN RVDT	A max	B	H	L	Fig.	g	RVDV EPDM code	RVDT EPDM code
16	10	16	10	125	72	114	14	A	110	RVDV016E	RVDT016E
20	15	16	10	125	72	124	16	A	120	RVDV020E	RVDT020E
25	20	16	10	145	84	144	19	A	190	RVDV025E	RVDT025E
32	25	16	10	165	95	154	22	A	285	RVDV032E	RVDT032E
40	32	16	10	190	111	174	26	A	400	RVDV040E	RVDT040E
50	40	16	10	210	120	194	31	A	600	RVDV050E	RVDT050E
63	50	16	10	240	139	224	38	A	945	RVDV063E	RVDT063E

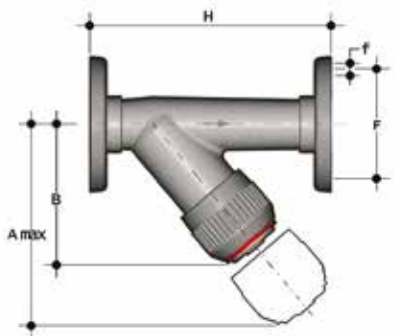

## RVOV-RVOT D 20 ÷ 63

RVOV PVC-U rigid - RVOT PVC-U transparent  
Sediment strainer with fixed flanges, drilled PN10/16

d	DN	PN RVOV	PN RVOT	A max	B	F	f	H	Fig.	g	RVOV EPDM code	RVOT EPDM code
20	15	16	10	125	72	65	14	130	A	260	RVOV020E	RVOT020E
25	20	16	10	145	84	75	14	150	A	395	RVOV025E	RVOT025E
32	25	16	10	165	95	85	14	160	A	560	RVOV032E	RVOT032E
40	32	16	10	190	111	100	18	180	A	850	RVOV040E	RVOT040E
50	40	16	10	210	120	110	18	200	A	1170	RVOV050E	RVOT050E
63	50	16	10	240	139	125	18	230	A	1760	RVOV063E	RVOT063E

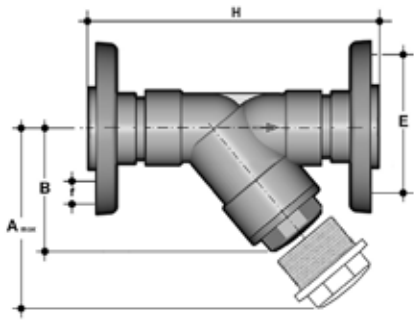

### RVOV-RVOT D 75 ÷ 110

RVOV PVC-U rigid - RVOT PVC-U transparent  
Sediment strainer with PVC-U backing ring, drilled PN10/16

d	DN	PN RVOV	PN RVOT	A max	B	F	f	H	Fig.	g	RVOV EPDM code	RVOT EPDM code
75	65	10	6	300	179	145	17	356	B	3600	RVOV075E	RVOT075E
90	80	6	4	325	192	160	17	404	B	4910	RVOV090E	RVOT090E
110	100	6	4	385	231	180	17	475	C	6790	RVOV110E	RVOT110E

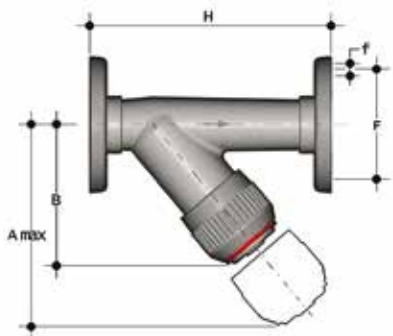

### RVOAV-RVOAT D 20 ÷ 63

RVOAV PVC-U rigid - RVOAT PVC-U transparent  
Sediment strainer with fixed flanges, drilled ANSI B16.5 cl.150 #FF

d	DN	PN RVOAV	PN RVOAT	A max	B	F	f	H	Fig.	g	RVOAV EPDM code	RVOAT EPDM code
1/2"	15	16	10	125	72	60,3	15,9	130	A	260	RVOAV012E	RVOAT012E
3/4"	20	16	10	145	84	69,9	15,9	150	A	395	RVOAV034E	RVOAT034E
1"	25	16	10	165	95	79,4	15,9	160	A	560	RVOAV100E	RVOAT100E
1 1/4"	32	16	10	190	111	88,9	15,9	180	A	850	RVOAV114E	RVOAT114E
1 1/2"	40	16	10	210	120	98,4	15,9	200	A	1170	RVOAV112E	RVOAT112E
2"	50	16	10	240	139	120,7	19,1	230	A	1760	RVOAV200E	RVOAT200E

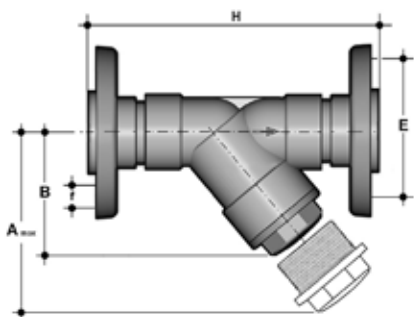

### RVOAV-RVOAT D 75 ÷ 110

RVOAV PVC-U rigid - RVOAT PVC-U transparent  
Sediment strainer with steel core backing ring, PP/FRP coated, drilled ANSI B16.5 cl.150 #FF

d	DN	PN RVOAV	PN RVOAT	A max	B	F	f	H	Fig.	g	RVOAV EPDM code	RVOAT EPDM code
2 1/2"	65	10	6	300	179	139,7	19,1	356	B	3600	RVOAV212E	RVOAT212E
3"	80	6	4	325	192	152,4	19,1	404	B	4910	RVOAV300E	RVOAT300E
4"	100	6	4	385	231	190,5	19,1	475	C	6790	RVOAV400E	RVOAT400E

# COMPONENTS

## EXPLODED VIEW

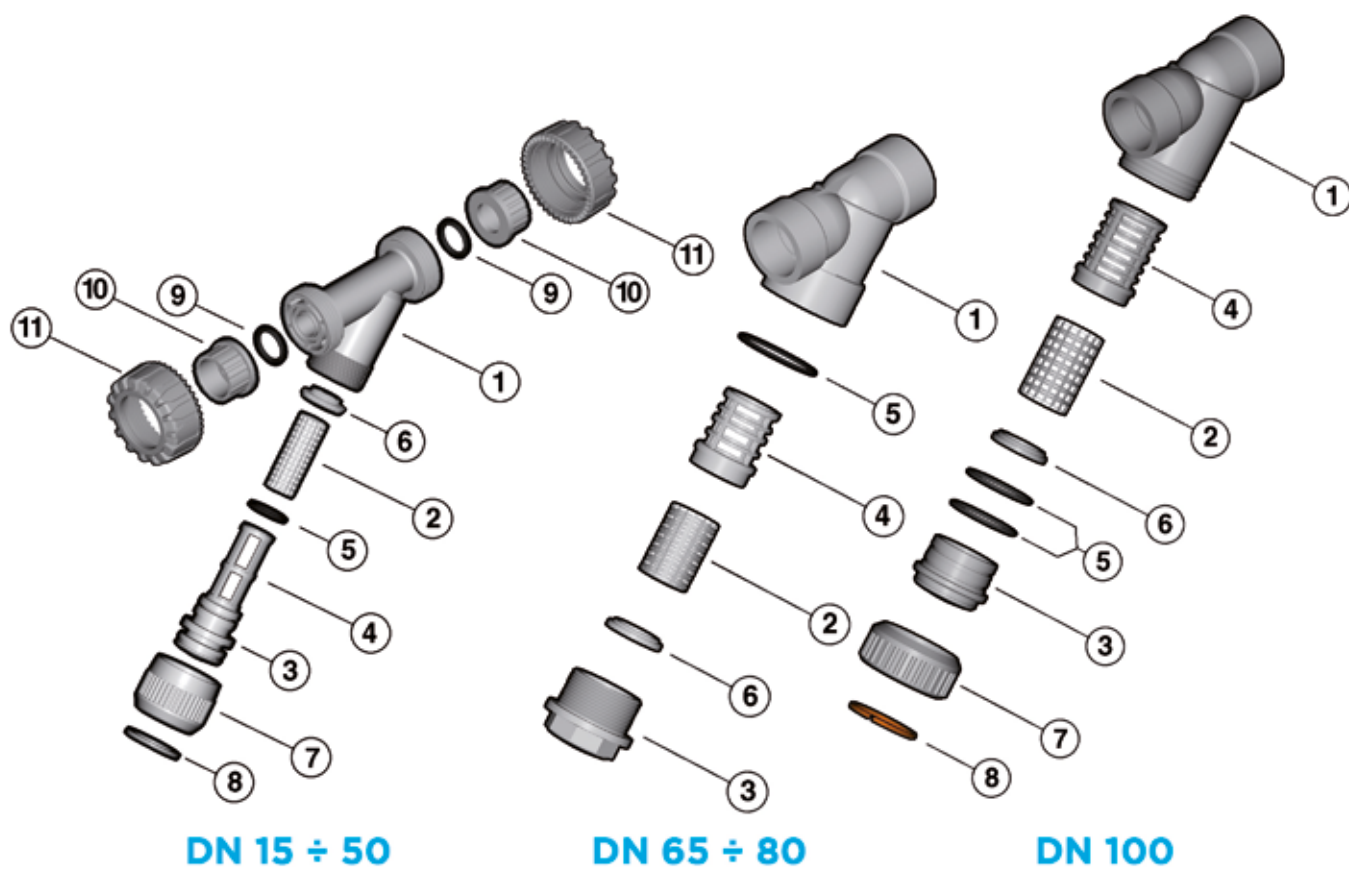

- 1** Body (PVC-U - 1)
- 2** Strainer (PVC-U/STAINLESS steel - 1)\*
- 3** Bonnet (PVC-U - 1)
- 4** Strainer support (PVC-U - 1)

- 5** O-Ring (EPDM-FKM - 1)\*
- 5 A-B** O-Ring (EPDM-FKM - 2)\*
- 5 C** O-Ring (EPDM-FKM - 2)\*
- 6** Washer (PVC-U - 1)
- 7** Union nut (PVC-U - 1)

- 8** Retaining ring (PVC-U - 1)
- 9** Socket seal O-Ring (EPDM-FKM - 2)\*
- 10** End connector (PVC-U - 2)\*
- 11** Union nut (PVC-U - 2)

\* Spare parts  
The material of the component and the quantity supplied are indicated between brackets

## DISASSEMBLY

### DN 15÷50 (FIG. A) - DN 100 (FIG. C)

- 1) Isolate the sediment strainer from the fluid flow and empty the system upstream.
- 2) Unscrew the union nut (7) and separate the bonnet-support (3-4) from the body (1).
- 3) Remove the bottom washer (6) from the bonnet-support (3-4).
- 4) Remove the retaining ring (8) and separate the union nut (7) from the bonnet (3).
- 5) Remove the O-Ring from the bonnet (5).

### DN 65÷80 (FIG. B)

- 1) Isolate the sediment strainer from the fluid flow and empty the system upstream.
- 2) Unscrew the bonnet (3) and separate it from the body (1).
- 3) Remove the support (4) from the bonnet (3).
- 4) Remove the washer (6) from the bonnet (3) and the O-Ring (5) from its seating in the body.

## ASSEMBLY

### DN 15÷50 (FIG. A) - DN 100 (FIG. C)

- 1) Insert the O-Ring (5) in its seating in the bonnet (3).
- 2) Insert the bonnet (3) in union nut (7) and fix the two components using the retaining ring (8).
- 3) Insert the strainer (2) in the bonnet support (3-4) and hold in place with the washer (6).
- 4) Insert the bonnet (3) in the body (1) and tighten the union nut (7).

### DN 65÷80 (FIG. B)

- 1) Insert the O-Ring (5) in the body (1)
- 2) Insert the washer (6) in the bonnet (3)
- 3) Insert the strainer (2) in its support (4)
- 4) Insert the support (4) in the bonnet (3)
- 5) Screw the bonnet (3) in the body (1)



**Note:** maintenance operations can be carried out with the valve body installed. During assembly, it is advisable to lubricate the rubber seals. Mineral oils are not recommended for this task as they react aggressively with EPDM rubber.

Fig. A

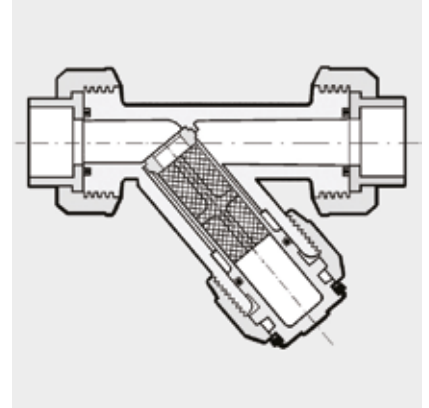

Fig. B

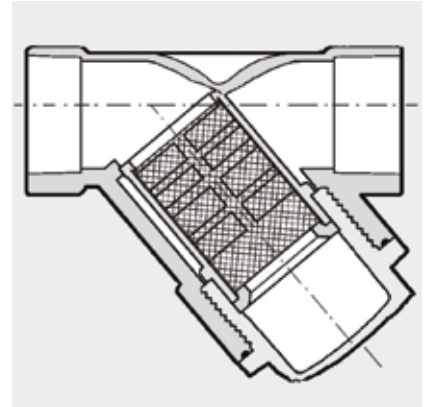
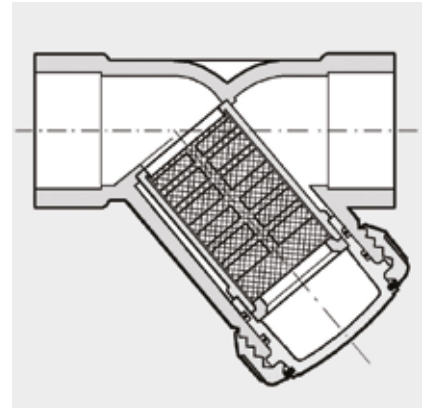

Fig. C



# INSTALLATION

## DN 15÷50 (fig. A)

The sediment strainer can be installed in any position, making sure that the arrow stamped on the body indicates the direction of fluid flow and that the strainer part is facing downwards. To avoid damaging the strainer, appropriate devices must be installed on the line to prevent backflow.

- 1) Unscrew the union nuts (11) and slide them onto the pipe.
- 2) Heat weld the end connectors (10) onto the pipe segments.
- 3) Position the sediment strainer between the end connectors
- 4) Tighten the union nuts.

## DN 65÷80 (fig. B) e DN 100 (fig. C)

The joint must be made by solvent welding the pipe directly into the socket of the valve body.

## WARNINGS

sediment strainers with a transparent body allow the passage of light, thus promoting the internal growth of algae and micro-organisms.

sediment strainers with a transparent body are not protected against solar rays. Use in an open-air system will accelerate the ageing process of the material and reduce its working life.

The sediment strainers with a transparent body located near pumps should be protected against vibrations.

Always check the cleanliness of the strainer elements.

Leave a straight section of pipe of length equal to 5 times the nominal diameter before and after the valve.