



DK DN 15÷65

PVC-C

DIALOCK® 2-WAY DIAPHRAGM VALVE



DK DN 15÷65

The DK DIALOCK® diaphragm valve is particularly suitable for shutting off and regulating abrasive or dirty fluids. The new internal geometry of the body increases flow coefficient, reduce pressure drop and allows a sensitive and precise adjustment along the entire stroke of the shutter. The DK is extremely compact and very light. The innovative handwheel is equipped with a patented immediate and ergonomic operating locking device that allows it to be adjusted and locked in any position.



DIALOCK® 2-WAY DIAPHRAGM VALVE

- Connection system for solvent weld, threaded and flanged joints
- **Optimised fluid dynamic design:** maximum output flow rate thanks to the optimised efficiency of the fluid dynamics that characterise the new internal geometry of the body
- **Internal components in metal, totally isolated from the fluid** and external environment
- **Modularity of the range:** only 2 handwheel and 4 diaphragm and bonnet sizes for 7 different valve sizes
- Non-rising handwheel that stays at the same height during rotation, equipped with a graduated optical indicator protected by a transparent PVC cap with seal O-Ring
- Bonnet fastening screws in stainless steel protected against the external environment by PE plugs. Absence of metal parts exposed to the external environment to prevent any risk of corrosion
- **New flanged bodies:** the new bodies, characterised by a monolithic flanged structure, are available in PVC-U, PVC-C, PP-H and PVDF. This design, free from body and flange joints, greatly reduces mechanical stress and increases system performance.
- **CDSA** (Circular Diaphragm Sealing Angle) system that, thanks to the uniform distribution of shutter pressure on the diaphragm seal, offers the following advantages:
 - reduction in the tightening torque of the screws fixing the actuator to the valve body
 - reduced mechanical stress on all valve components (actuator, body and diaphragm)
 - easy to clean valve interior
 - low risk of the accumulation of deposits, contamination or damage to the diaphragm due to crystallisation
 - operating torque reduction

Technical specifications	
Construction	Diaphragm valve with maximized flow rate and DIALOCK® lockable handwheel
Size range	DN 15 ÷ 65
Nominal pressure	PN 10 with water at 20° C
Temperature range	0 °C ÷ 100 °C
Coupling standards	Solvent welding: EN ISO 15493, ASTM F 439. Can be coupled to pipes according to EN ISO 15493, ASTM F 441. Thread: ISO 228-1, DIN 2999. Flanging system: ISO 7005-1, EN ISO 15493, EN 558-1, DIN 2501, ANSI B.16.5 cl.
Reference standards	Construction criteria: EN ISO 16138, EN ISO 15493 Test methods and requirements: ISO 9393 Installation criteria: DVS 2204, DVS 2221, UNI 11242
Valve material	Body: PVC-C Bonnet and handwheel: PP-GR Position indicator cap: PVC
Seal material	EPDM, FKM, PTFE
Control options	Manual control; pneumatic actuator

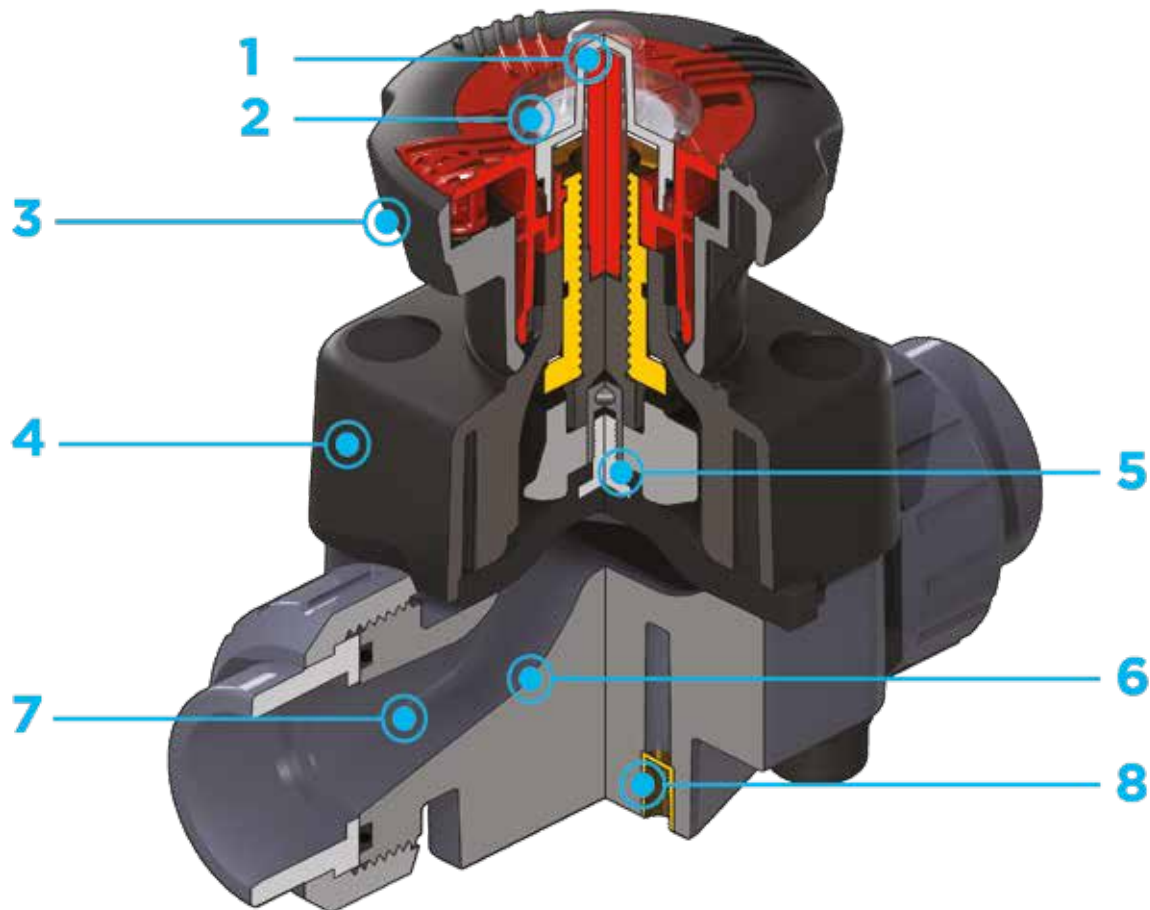

- 1 High visibility graduated optical position indicator** protected by a transparent cap with seal O-Ring
- 2 Customisation plate:** the customisation lets you identify the valve on the system according to specific needs
- 3 DIALOCK® SYSTEM:** innovative handwheel with a patented **immediate and ergonomic operating locking device** that allows it **to be adjusted and locked in over 300 positions**
- 4 Handwheel and bonnet in** high mechanical strength and chemically resistant **PP-GR**, providing full protection by isolating all internal metal parts from contact with external agents
- 5 Floating pin connection** between the control screw and diaphragm to prevent concentrated loads, improve the seal and extend its lifetime
- 6 New design of valve body interior:** **substantially increased flow coefficient** and reduced pressure drop. The degree of efficiency reached has also enabled **the size and weight** of the valve to be **reduced**
- 7 Adjustment linearity:** the internal profiles of the valve also greatly improve its characteristic curve, resulting in **extremely sensitive and precise adjustment** along the entire stroke of the shutter
- 8 Valve anchoring bracket integrated in the body**, with threaded metal inserts allowing **simple panel or wall mounting** using the PMDK mounting plate (supplied as an accessory)

TECHNICAL DATA

PRESSURE VARIATION ACCORDING TO TEMPERATURE

For water and non-hazardous fluids with regard to which the material is classified as CHEMICALLY RESISTANT. In other cases, a reduction of the nominal pressure PN is required (25 years with safety factor).



PRESSURE DROP GRAPH



K_v100 FLOW COEFFICIENT

The K_v100 flow coefficient is the Q flow rate of litres per minute of water at a temperature of 20°C that will generate Δp= 1 bar pressure drop at a certain valve position. The Kv100 values shown in the table are calculated with the valve completely open.

DN	15	20	25	32	40	50	65
Kv100 l/min	112	261	445	550	1087	1648	1600

RELATIVE FLOW COEFFICIENT GRAPH

The relative flow coefficient is the flow rate through the valve as a function of the degree of valve opening.

Horizontal axis: Percentage opening of the valve

Vertical axis: Relative flow coefficient

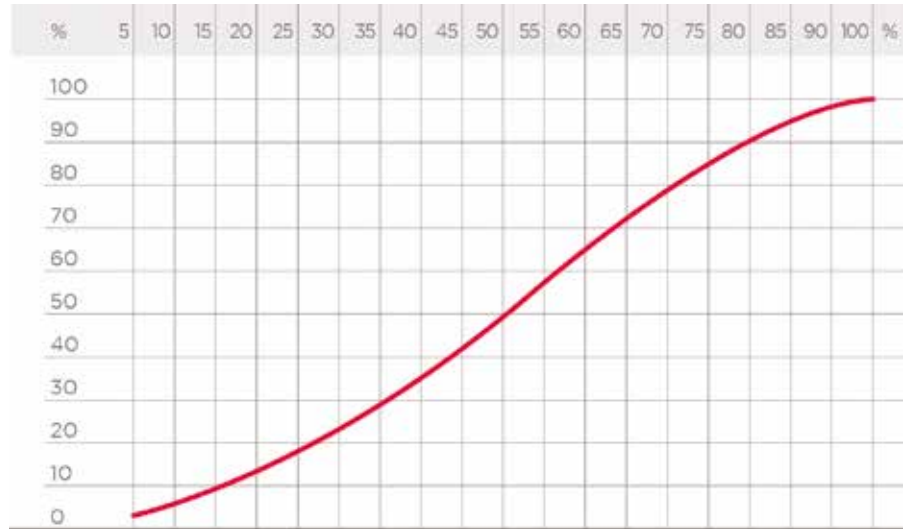

DIMENSIONS

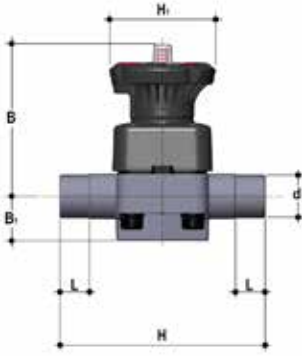

DKDC

DIALOCK® diaphragm valve with male ends for solvent welding, metric series

d	DN	PN	B	B ₁	H	H ₁	L	g	EPDM code	FKM code	PTFE code
20	15	10	102	25	124	80	16	466	DKDC020E	DKDC020F	DKDC020P
25	20	10	105	30	144	80	19	491	DKDC025E	DKDC025F	DKDC025P
32	25	10	114	33	154	80	22	696	DKDC032E	DKDC032F	DKDC032P
40	32	10	119	30	174	80	26	743	DKDC040E	DKDC040F	DKDC040P
50	40	10	149	35	194	120	31	1574	DKDC050E	DKDC050F	DKDC050P
63	50	10	172	46	224	120	38	2310	DKDC063E	DKDC063F	DKDC063P
75	65	10	172	46	284	120	44	2430	DKDC075E	DKDC075F	DKDC075P

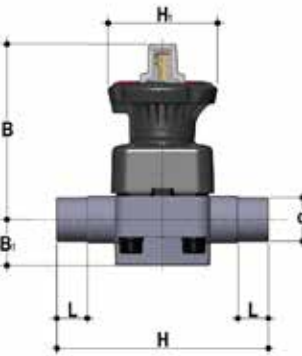

DKLDC

DIALOCK® diaphragm valve with stroke limiter and male ends for solvent welding, metric series

d	DN	PN	B	B ₁	H	H ₁	L	g	EPDM code	FKM code	PTFE code
20	15	10	115	25	124	80	16	496	DKLDC020E	DKLDC020F	DKLDC020P
25	20	10	118	30	144	80	19	521	DKLDC025E	DKLDC025F	DKLDC025P
32	25	10	127	33	154	80	22	726	DKLDC032E	DKLDC032F	DKLDC032P
40	32	10	132	30	174	80	26	773	DKLDC040E	DKLDC040F	DKLDC040P
50	40	10	175	35	194	120	31	1634	DKLDC050E	DKLDC050F	DKLDC050P
63	50	10	200	46	224	120	38	2370	DKLDC063E	DKLDC063F	DKLDC063P
75	65	10	200	46	284	120	44	2490	DKLDC075E	DKLDC075F	DKLDC075P

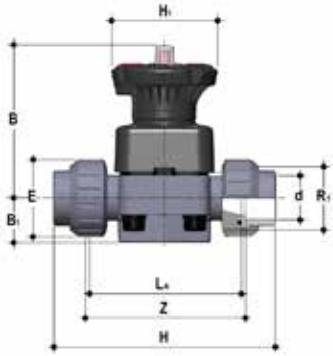

DKUIC

DIALOCK® diaphragm valve with female union ends for solvent welding, metric series

d	DN	PN	B	B ₁	E	H	H ₁	L ₁	R ₁	Z	g	EPDM code	FKM code	PTFE code
20	15	10	102	25	41	129	80	90	1"	100	509	DKUIC020E	DKUIC020F	DKUIC020P
25	20	10	105	30	50	154	80	108	1 1/4"	116	576	DKUIC025E	DKUIC025F	DKUIC025P
32	25	10	114	33	58	168	80	116	1 1/2"	124	812	DKUIC032E	DKUIC032F	DKUIC032P
40	32	10	119	30	72	192	80	134	2"	140	945	DKUIC040E	DKUIC040F	DKUIC040P
50	40	10	149	35	79	222	120	154	2 1/4"	160	1814	DKUIC050E	DKUIC050F	DKUIC050P
63	50	10	172	46	98	266	120	184	2 3/4"	190	2752	DKUIC063E	DKUIC063F	DKUIC063P

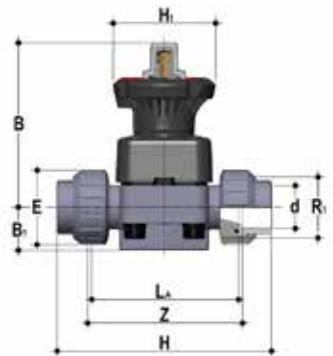

DKLUIC

DIALOCK® diaphragm valve with stroke limiter and female union ends for solvent welding, metric series

d	DN	PN	B	B ₁	E	H	H ₁	L ₁	R ₁	Z	g	EPDM code	FKM code	PTFE code
20	15	10	115	25	41	129	80	90	1"	100	539	DKLUIC020E	DKLUIC020F	DKLUIC020P
25	20	10	118	30	50	154	80	108	1 1/4"	116	606	DKLUIC025E	DKLUIC025F	DKLUIC025P
32	25	10	127	33	58	168	80	116	1 1/2"	124	842	DKLUIC032E	DKLUIC032F	DKLUIC032P
40	32	10	132	30	72	192	80	134	2"	140	975	DKLUIC040E	DKLUIC040F	DKLUIC040P
50	40	10	175	35	79	222	120	154	2 1/4"	160	1874	DKLUIC050E	DKLUIC050F	DKLUIC050P
63	50	10	200	46	98	266	120	184	2 3/4"	190	2812	DKLUIC063E	DKLUIC063F	DKLUIC063P

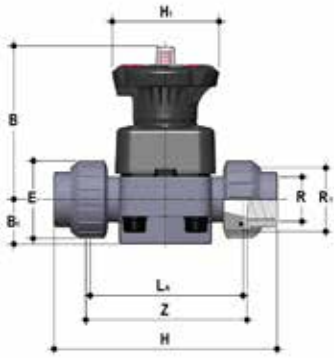

DKUFC

DIALOCK® diaphragm valve with BSP threaded female union ends

R	DN	PN	B	B ₁	E	H	H ₁	L _a	R ₁	Z	g	EPDM code	FKM code	PTFE code
1/2"	15	10	102	25	41	131	80	90	1"	97	509	DKUFC012E	DKUFC012F	DKUFC012P
3/4"	20	10	105	30	50	151	80	108	1 1/4"	118	576	DKUFC034E	DKUFC034F	DKUFC034P
1"	25	10	114	33	58	165	80	116	1 1/2"	127	812	DKUFC100E	DKUFC100F	DKUFC100P
1 1/4"	32	10	119	30	72	188	80	134	2"	145	945	DKUFC114E	DKUFC114F	DKUFC114P
1 1/2"	40	10	149	35	79	208	120	154	2 1/2"	165	1814	DKUFC112E	DKUFC112F	DKUFC112P
2"	50	10	172	46	98	246	120	184	2 3/4"	195	2752	DKUFC200E	DKUFC200F	DKUFC200P

DKLUFC version available on request

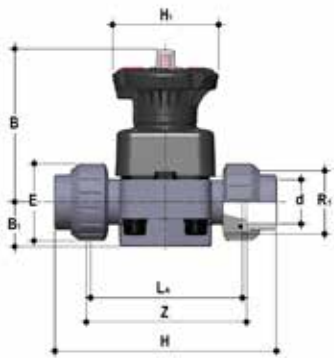

DKUAC

DIALOCK® diaphragm valve with female union ends for solvent welding, ASTM series

d	DN	PN	B	B ₁	E	H	H ₁	L _a	R ₁	Z	g	EPDM code	FKM code	PTFE code
1/2"	15	10	102	25	41	143	80	90	1"	98	509	DKUAC012E	DKUAC012F	DKUAC012P
3/4"	20	10	105	30	50	167	80	108	1 1/4"	115	576	DKUAC034E	DKUAC034F	DKUAC034P
1"	25	10	114	33	58	180	80	116	1 1/2"	122	812	DKUAC100E	DKUAC100F	DKUAC100P
1 1/4"	32	10	119	30	72	208	80	134	2"	144	945	DKUAC114E	DKUAC114F	DKUAC114P
1 1/2"	40	10	149	35	79	234	120	154	2 1/2"	164	1814	DKUAC112E	DKUAC112F	DKUAC112P
2"	50	10	172	46	98	272	120	184	2 3/4"	195	2752	DKUAC200E	DKUAC200F	DKUAC200P

DKLUAC version available on request

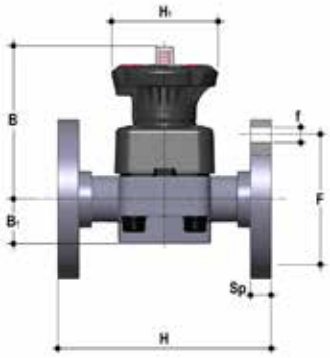

DKOC

DIALOCK® diaphragm valve with flanged monolithic body, drilled PN10/16. Face to face according to EN 558-1

d	DN	PN	B	B ₁	f	F	H	H ₁	Sp	U	g	EPDM code	FKM code	PTFE code
20	15	10	102	25	65	14	130	80	13,5	4	962	DKOC020E	DKOC020F	DKOC020P
25	20	10	105	30	75	14	150	80	13,5	4	1038	DKOC025E	DKOC025F	DKOC025P
32	25	10	114	33	85	14	160	80	13,5	4	1122	DKOC032E	DKOC032F	DKOC032P
40	32	10	119	30	100	18	180	80	14	4	1364	DKOC040E	DKOC040F	DKOC040P
50	40	10	149	35	110	18	200	120	16	4	2299	DKOC050E	DKOC050F	DKOC050P
63	50	10	172	46	125	18	230	120	16	4	3200	DKOC063E	DKOC063F	DKOC063P
75	65	10	172	46	145	18	290	120	21	4	3873	DKOC075E	DKOC075F	DKOC075P

DKLOC version available on request

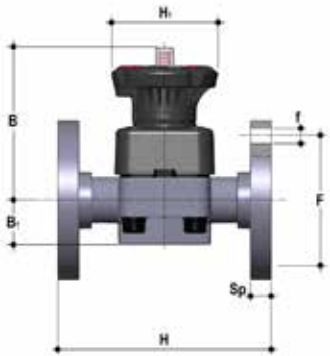

DKOAC

DIALOCK® diaphragm valve with flanged monolithic body, drilled ANSI B16.5 cl. 150 #FF

d	DN	PN	B	B ₁	f	F	H	H ₁	Sp	U	g	EPDM code	FKM code	PTFE code
1/2"	15	10	102	25	60.3	14	108	80	13,5	4	962	DKOAC012E	DKOAC012F	DKOAC012P
3/4"	20	10	105	30	70	15.7	120	80	13,5	4	1038	DKOAC034E	DKOAC034F	DKOAC034P
1"	25	10	114	33	80	15.7	131	80	13,5	4	1122	DKOAC100E	DKOAC100F	DKOAC100P
1" 1/4	32	10	119	30	89	15.7	162	80	14	4	1364	DKOAC114E	DKOAC114F	DKOAC114P
1" 1/2	40	10	149	35	99	15.7	180	120	16	4	2299	DKOAC112E	DKOAC112F	DKOAC112P
2"	50	10	172	46	121	19	210	120	16	4	3200	DKOAC200E	DKOAC200F	DKOAC200P
2" 1/2	65	10	172	46	140	19	250	120	21	4	3873	DKOAC212E	DKOAC212F	DKOAC212P

DKLOAC version available on request
For installation prior to october 2017 please contact Fip Technical Support

ACCESSORIES

Q/BBE-L

Long spigot PE100 end connectors for electrofusion or butt welding

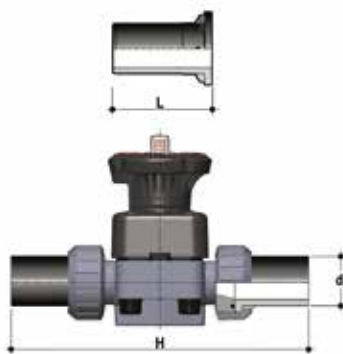

d	DN	PN	L	H	SDR	Code
20	15	16	95	280	11	QBBEL11020
25	20	16	95	298	11	QBBEL11025
32	25	16	95	306	11	QBBEL11032
40	32	16	95	324	11	QBBEL11040
50	40	16	95	344	11	QBBEL11050
63	50	16	95	374	11	QBBEL11063

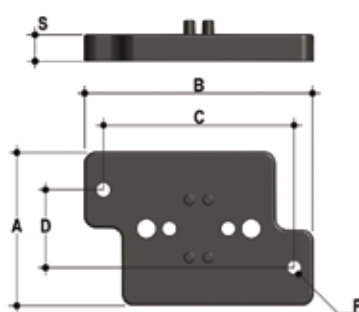

PMDK

Wall mounting plate

d	DN	A	B	C	D	F	S	Code
20	15	65	97	81	33	5,5	11	PMDK1
25	20	65	97	81	33	5,5	11	PMDK1
32	25	65	97	81	33	5,5	11	PMDK1
40	32	65	97	81	33	5,5	11	PMDK2
50	40	65	144	130	33	6,5	11	PMDK2
63	50	65	144	130	33	6,5	11	PMDK2
75	65	65	144	130	33	6,5	11	PMDK2

FASTENING AND SUPPORTING



All valves, whether manual or actuated, must be adequately supported in many applications.

The DK valve series is therefore provided with an integrated bracket that permits direct anchoring of the valve body without the need of other components.

For wall or panel installation, dedicated PMDK mounting plates which are available as accessories can be used. These plates should be fastened to the valve before wall installation.

PMDK plates also allow DK valve alignment with FIP ZIKM pipe clips.

d	DN	h	l	j
20	15	10	25	M6
25	20	10	25	M6
32	25	10	25	M6
40	32	10	25	M6
50	40	13	44,5	M8
63	50	13	44,5	M8
75	65	13	44,5	M8

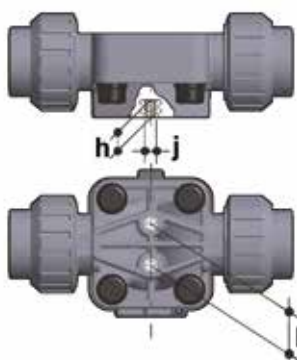

CUSTOMISATION

Fig. 1



Fig. 2



Fig. 3



The DIALOCK® DK DN 15÷65 valve can be customised using a customisation plate in white PVC.

The customisation plate (B), housed in the transparent protection cap (A), can be removed and, once overturned, used for indicating identification serial numbers or service indications on the valves such as, for example, the valve function in the system, the conveyed fluid, but also specific information for customer service, such as the customer name or installation date or location on the valves. The waterproof transparent protection cap with seal O-Ring protects the customisation plate against deterioration.

To access the customisation plate, make sure the handwheel is in the unlock position and proceed as follows:

- 1) Turn the transparent protection cap anti-clockwise to limit stop (fig. 1) and remove it by pulling it upwards and, if necessary, by inserting a screwdriver into the slot (C) to facilitate operation (fig. 2).
- 2) Remove the plate inside the transparent protection cap and customise it as required (fig. 3).
- 3) Re-assemble, making sure that the seal O-Ring of the transparent protection cap remains in its seating (fig. 4).

Fig. 4



COMPONENTS

EXPLODED VIEW

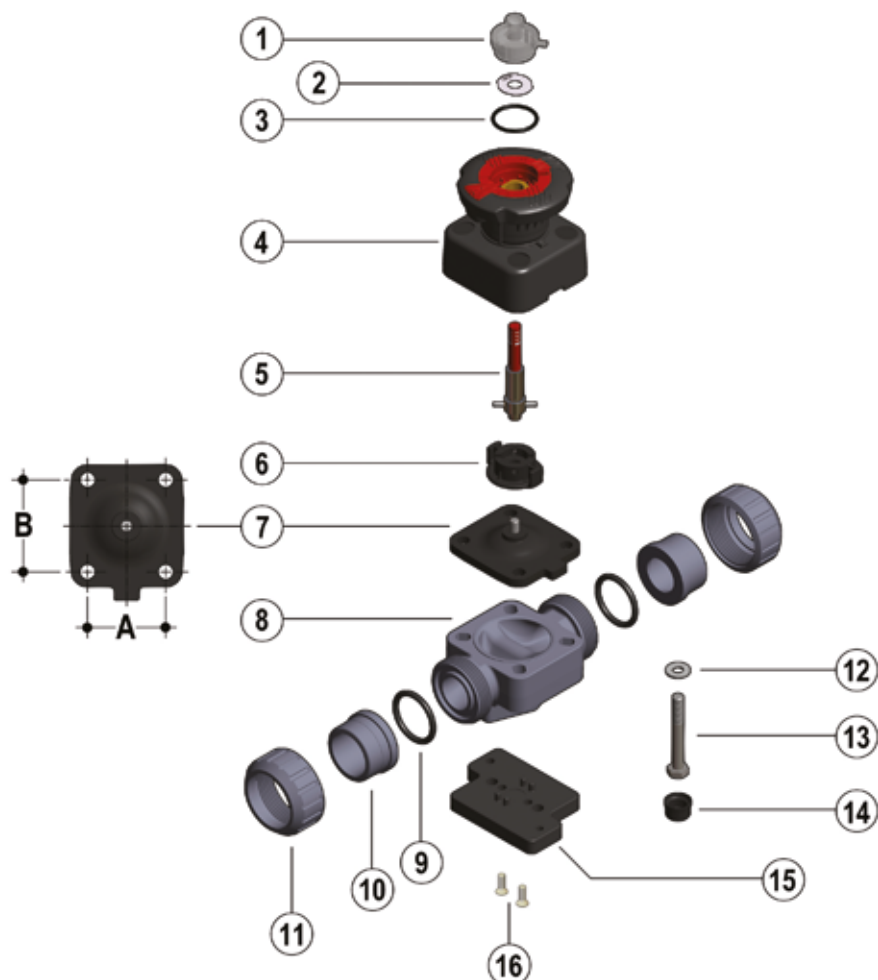

DN	15	20	25	32	40	50	65
A	40	40	46	46	65	78	78
B	44	44	54	54	70	82	82

- | | | |
|--|--|---|
| 1 Transparent protection cap (PVC - 1)* | 6 Compressor (PA-GR IXEF® - 1) | 11 Union nut (PVC-C - 2)* |
| 2 Customisation plate (PVC-U - 1) | 7 Diaphragm seal (EPDM, FKM, PTFE - 1)* | 12 Washer (STAINLESS steel - 4) |
| 3 O-Ring (EPDM - 1) | 8 Valve body (PVC-C - 1)* | 13 Bolt (STAINLESS steel - 4) |
| 4 Operating mechanism (PP-GR / PVDF - 1) | 9 Socket seal O-Ring (EPDM-FKM - 2)* | 14 Protection plug (PE - 4) |
| 5 Threaded stem – Indicator (STAINLESS steel - 1) | 10 End connector (PVC-C - 2)* | 15 Distance plate (PP-GR - 1)** |
| | | 16 Screw (STAINLESS steel - 2)** |

* Spare parts

** Accessories

The material of the component and the quantity supplied are indicated in brackets

DISASSEMBLY

- 1) Isolate the valve from the line (release the pressure and empty the pipeline).
- 2) Unlock the handwheel if necessary by pushing it downwards (fig.5), and open the valve completely by turning it counter-clockwise.
- 3) Unscrew the union nuts (11) and extract the valve.
- 4) Remove the protection plugs (14) and remove the bolts (13) with the relative washers (12).
- 5) Separate the valve body (8) from the operating mechanism (4).
- 6) Rotate the handwheel clockwise until the threaded stem (5), the compressor (6) and the diaphragm (7) are released.
- 7) Unscrew the diaphragm (7) and remove the shutter (6).

ASSEMBLY

- 1) Insert the compressor (6) onto the threaded stem (5), aligning it correctly with the stem pin.
- 2) Screw the diaphragm (7) onto the threaded stem (5).
- 3) Lubricate the threaded stem (5) and insert it into the operating mechanism (4), then turn the handwheel counter-clockwise until the stem is fully screwed in (5). Make sure that the compressor (6) and the diaphragm are properly aligned with the respective slots in the operating mechanism (4) (fig. 7).
- 4) Assemble the operating mechanism (4) on the body of the valve (8) and tighten the bolts (13) with the relative washers (12).
- 5) Tighten the bolts (13) evenly (diagonally) to the tightening torque suggested on the relative instruction sheet.
- 6) Replace the protection plugs (14).
- 7) Position the valve body between the end connectors (10) and tighten the union nuts (11), making sure that the socket seal O-rings (9) do not exit their seats.
- 8) If necessary, lock the handwheel by gripping it and pulling it upwards (fig.6).



Note: during assembly operations, it is advisable to lubricate the threaded stem Mineral oils are not recommended for this task as they react aggressively with EPDM rubber.

Fig. 5



Fig. 6



Fig. 7



INSTALLATION

Before proceeding with installation, please follow these instructions carefully: (instructions refer to versions with union ends). The valve can be installed in any position and in any direction.

- 1) Check that the pipes to be connected to the valve are aligned in order to avoid mechanical stress on the threaded joints.
- 2) Unscrew the union nuts (11) and insert them on the pipe segments.
- 3) Solvent weld or screw the end connectors (10) onto the pipe ends.
- 4) Position the valve body between the end connectors making sure the socket seal O-Rings (9) do not exit the seats.
- 5) Fully tighten the union nuts (11).
- 6) If necessary, support the pipework with FIP pipe clips or by means of the carrier built into the valve itself (see paragraph "Fastening and supporting").

Note: Before putting the valve into service, check that the bolts on the valve body (13) are tightened correctly at the suggested torque.

LOCKING DEVICE

The DK valve is equipped with a DIALOCK® handwheel locking system that prevents the valve from being operated.

The system can be used simply by lifting the handwheel once it reaches the desired position (fig. 8).

To unlock, simply move the handwheel back to the previous position by pressing downwards (fig. 6).

When the system is in a locked position, it is also possible to install a lock to protect the system against tampering (fig. 9).

The diameter of the hole to put the padlock in is 4,5 mm for the dimensions between DN 15 and DN 32 and 6,5 mm for the dimensions between DN 40 and DN 65.

STROKE LIMITER

The DKL version of the diaphragm valve is equipped with a handwheel stroke control system which allows the minimum and maximum flows to be preset and preserves the diaphragm from excessive compression during closing operations. The system allows the valve stroke to be modified using the two independent adjusting screws, which determine the mechanical limits of the valve during opening and closing. The valve is sold with the stroke limiters positioned so as not to limit the stroke both during closing and opening.

To access and set the adjusting screws, remove the transparent protection cap (A) as previously described (see chapter "Customisation").

Travel stop adjustment. Minimum flow rate or valve closed.

- 1) Turn the handwheel clockwise until the desired minimum flow rate or the closed position is reached.
- 2) Fully screw the nut (D) to limit stop, and lock it in this position by tightening the locknut (E). If you want to exclude the stroke limiting function during closing, unscrew the nuts (D and E) completely. In this way, the valve will close completely.
- 3) Re-assemble the transparent protection cap making sure that the seal O-Ring remains in its seating.

Stroke limiter adjustment. Maximum flow rate

- 1) Turn the handwheel counter-clockwise until the desired maximum flow rate is reached.
- 2) Turn the knob (F) counter-clockwise to limit stop. The plate shows the direction of rotation of the wheel to obtain a smaller or greater maximum flow rate. If it is not necessary to limit the opening stroke, turn the knob (F) clockwise several times. In this way, the valve will open completely.
- 3) Re-assemble the transparent protection cap making sure that the seal O-Ring remains in its seating.

Fig. 9

