

Technical catalogue



Butterfly actuated valves
in PVC-U, PVC-C, PP-H, PVDF
Solenoid valves in PVC-U



Pressure piping fluids conveying



Contents

PVC-U - PVC-C - PP-H - PVDF

General characteristics PVC-U	4
Main properties PVC-U	6
General characteristics PVC-C	7
Main properties PVC-C	9
General characteristics PP-H	10
Main properties PP-H	12
General characteristics PVDF	13
Main properties PVDF	15
Reference standards	18
Approvals and quality marks	20

FE/CE-FE/CP DN 40÷200

Electrically or pneumatically actuated butterfly valve	24
--	----

FK/CE-FK/CP DN 40÷400

Electrically or pneumatically actuated butterfly valve	46
--	----

S1-S2 DN 4÷15

2-way radial dismounting solenoid valve	145
---	-----

ACCESSORIES

Electrically actuated valves accessories	158
Pneumatically actuated valves accessories	165

LEGEND

171



GENERAL CHARACTERISTICS AND MATERIAL PROPERTIES

PVC-U / PVC-C / PP-H / PVDF



PVC-U

General characteristics

Developed in 1930 in Germany, PVC-U (rigid polyvinyl chloride- unplasticized) is obtained through the polymerization of a vinyl chloride monomer.

The presence of chlorine in the PVC-U molecule results in a high performance resin, in terms of thermal stability and chemical and mechanical resistance, up to temperatures of 60° C.

The different formulations obtained by adding suitable additives and stabilizers render the PVC-U the most versatile of all plastic materials, allowing it to be adapted to many applications involving fluids under pressure.

PVC-U represents one of the more economic solutions in the field of thermoplastic and metal materials for resolving problems in the transport of corrosive chemical fluids, and in the distribution and treatment of water in general.

The main reasons for this preference are the unique characteristics of the resin, which include:

- **Good chemical resistance:** PVC-U resins have excellent chemical resistance to most acids and alkalis, paraffin/aliphatic hydrocarbons and saline solutions. It is not recommended for the transport of polar organic compounds, including some types of chlorinated and aromatic solvents.

PVC-U resins are also fully compatible with the transport of foodstuffs, demineralised water, potable water and unconditioned water, as provided for by current national and international standards.

PVC-U resins are also characterised by their low permeability to oxygen and reduced water absorption (0.1% at 23 °C according to ASTM D 570).

- **Good thermal stability:** PVC-U resins have good thermal stability in the temperature range between 20 °C and 50 °C and are typically used in industrial and water supply applications, guaranteeing excellent mechanical strength, sufficient rigidity for the purpose, reduced thermal expansion coefficients and high factors of safety in service.

PVC-U compounds are also resistant to combustion with a flash point of 399 °C.

The flame, in fact, only persists if the oxygen concentration is twice that of atmospheric or in the presence of a flame from an external source. Flash point: 399° C. Oxygen index: 45%. UL 94 class: V0. Thanks to the reduced coefficient of thermal conductivity ($\lambda = 0.15 \text{ W/m } ^\circ\text{C}$ according to ASTM C177) the use of PVC-U resin for transporting hot fluids reduces heat loss and virtually eliminates condensation problems.









- **Good mechanical strength:** The thermal stability of the material leads to good impact resistance and the capacity to support service pressures of 4 – 6 – 10 – 16 bar at 20°C.

- **Resistance to ageing:** PVC-U resins have a high circumferential breaking strength (Minimum Required Strength MRS $\geq 25.0 \text{ MPa}$ at 20°C) and allow long installation lifetimes without showing any signs of significant physical-mechanical deterioration.

Density	
Test method	ISO 1183 - ASTM D792
Unit of measurement	g/cm ³
Value	1.38
Modulus of elasticity	
Test method	ISO 527
Unit of measurement	MPa = N/mm ²
Value	3200
IZOD notched impact strength at 23°C	
Test method	ASTM D256
Unit of measurement	J/m
Value	50
Ultimate elongation	
Test method	ISO 527
Unit of measurement	%
Value	50
Shore hardness	
Test method	ISO 868
Unit of measurement	Shore D
Value	80
Tensile strength	
Test method	ISO 527
Unit of measurement	MPa = N/mm ²
Value	50
VICAT softening point (B/50)	
Test method	ISO 306
Unit of measurement	°C
Value	76
Heat distortion temperature HDT (0.46 N/mm²)	
Test method	ASTM D648
Unit of measurement	°C
Value	86
Thermal conductivity at 23° C	
Test method	DIN 52612-1 - ASTM C177
Unit of measurement	W/(m °C)
Value	0.16
Coefficient of linear thermal expansion	
Test method	DIN 53752 - ASTM D696
Unit of measurement	m/(m °C)
Value	8 x 10 ⁻⁵
Limiting Oxygen Index	
Test method	ISO 4859-1 - ASTM D2863
Unit of measurement	%
Value	45

Main properties

PVC-U

Properties of PVC-U		Benefits
Thermal resistance		<ul style="list-style-type: none"> • Service range 0–60 °C (see pressure/temperature regression curve)
Low surface roughness		<ul style="list-style-type: none"> • High flow coefficients (extremely smooth internal walls) • Pressure drop constant over time • Low risk of stoppages due to scaling • Reduced transfer of material to the transported fluid
Chemical resistance		<ul style="list-style-type: none"> • Good chemical resistance for conveying acids and alkalis, paraffin/aliphatic hydrocarbons and saline solutions.
Abrasion resistance		<ul style="list-style-type: none"> • Extremely low operating costs due to its long service life
Insulating		<ul style="list-style-type: none"> • Non-conductive (immune to galvanic corrosion) • No condensation problems • Minimum heat loss
Linear thermal expansion coefficients		<ul style="list-style-type: none"> • Reduced need for supports and expansion joints, resulting in considerable advantages in terms of plant design
Easy to join (solvent weld sockets)		<ul style="list-style-type: none"> • Reduced installation costs thanks to the "solvent weld" joint effected using a suitable solvent cement
Fire behaviour		<ul style="list-style-type: none"> • Good resistance to combustion also due to the presence of self-extinguishing chlorine
Good mechanical resistance		<ul style="list-style-type: none"> • PVC-U satisfies the need to provide adequate mechanical strength and complies with the requirements of industrial plant design

PVC-C

General characteristics

Developed in 1958 by the company BF Goodrich, now LUBRIZOL, PVC-C (post-chlorinated polyvinyl chloride) is obtained by chlorinating the PVC resin in suspension. During the transformation, alternate hydrogen atom monomers in the PVC molecular chain are replaced by Chlorine atoms. The process produces a high performance resin with excellent thermal stability and chemical and mechanical strength up to temperatures of 100°C.

In 1986, FIP was the first European Company to produce an integrated system of valves, fittings and pipes called **TemperFIP100®**.

The result was the creation of an entire series of products for industrial plants. Given the twenty-year old partnership with LUBRIZOL EUROPE, now the Temper FIP line uses **PVC-C CORZAN™** resins specifically formulated for industrial applications to produce pipes, fittings and valves made by extrusion and injection moulding. PVC-C resins are fully compatible for use in transporting water to treatment plants, as well as for conveying demineralised and spa water.

The PVC-C TemperFIP100® system represents one of the more economical solutions in the field of thermoplastic materials and metals, able to resolve the difficulties encountered in process and service lines transporting hot corrosive fluids in the industrial sector, as well as in domestic hot and cold water distribution systems.









The main reasons for this preference are the unique chemical and physical characteristics of the resin, which include:

- **High chemical resistance:** the use of CORZAN™ resin, obtained through the chlorination of homopolymer PVC, can guarantee high chemical resistance, in particular against strong inorganic acids, saline and alkaline solutions and paraffin hydrocarbons. It is not recommended for the transport of polar organic compounds, including some types of chlorinated and aromatic solvents. Its electrochemical corrosion resistance guarantees excellent reliability for conveying domestic hot water in conventional and solar panel systems.
- **Optimum thermal and mechanical properties:** TemperFIP100® PVC-C is typically used in temperatures between 20°C and 85°C and has extremely low thermal expansion coefficients, thus guaranteeing excellent mechanical strength able to withstand service pressures of around 10-16 bar at 20°C. Its excellent thermal stability (VICAT value according to EN ISO 15493) together with its optimum creep behaviour (circumferential breaking strength according to ASTM D 2837 equal to 1000 PSI 82 °C, 100,000 hours) allows it to be used at temperatures up to around 95 °C for special applications and to satisfy particular performance requirements. The reduced coefficient of thermal conductivity ($\lambda = 0.16 \text{ W/m } ^\circ\text{C}$ according to ASTM C177) virtually eliminates condensation problems and reduces heat loss when transporting hot fluids.
- **Physical characteristics:** PVC-U resins are characterised by their low permeability to oxygen and reduced water absorption (0.07% at 23 °C according to ASTM D 570). The physical properties of the material render it highly resistant to ageing and aggression by atmospheric agents (UV radiation) thanks to the presence of Titanium dioxide in the compound.
- **Fire resistance:** PVC-U resins also have excellent fire resistance with a flash point of 482 °C. The flame, in fact, only persists if the oxygen concentration is three times that of atmospheric or in the presence of a flame from an external source. PVC-C CORZAN™ resins are also classified VO, 5VB and 5VA according to UL94.

Density		
Test method	ISO 1183	ASTM D792
Unit of measurement	g/cm ³	g/(10 min)
Value	Valves/fittings: 1.50 Pipes: 1.50	Valves/fittings: 1.50 Pipes: 1.50
Modulus of elasticity		
Test method	ISO 178	ASTM D790
Unit of measurement	MPa = N/mm ²	MPa = N/mm ²
Value	Valves/fittings: 2800 Pipes: 2420	Valves/fittings: 2992 Pipes: 2689
IZOD notched impact strength at 23°C		
Test method	ASTM D256	
Unit of measurement	ftlbs/in	
Value	Valves/fittings: 1.8 - Pipes: 1.6	
Ultimate elongation		
Test method	ISO 527-1, ISO 527-2	
Unit of measurement	%	
Value	Valves/fittings: 16 - Pipes: 5	
Rockwell hardness		
Test method	ASTM D 785	
Unit of measurement	R	
Value	Valves/fittings: 120 - Pipes: 116	
Tensile strength		
Test method	ISO 527-1, ISO 527-2	
Unit of measurement	MPa = N/mm ²	
Value	Valves/fittings: 54 - Pipes: 54	
VICAT softening point (1 kg)		
Test method	EN ISO 15493	
Unit of measurement	°C	
Value	Valves/fittings: ≥ 103 - Pipes: ≤ 110	
Heat distortion temperature HDT (0.46 N/mm²)		
Test method	ASTM D648	
Unit of measurement	°C	
Value	Valves/fittings: 110 - Pipes: 113	
Thermal conductivity at 23° C		
Test method	DIN 52612-1	ASTM C 177
Unit of measurement	W/(m °C)	W/(m °C)
Value	Valves/fittings: 0.16 Pipes: 0.16	Valves/fittings: 0.16 Pipes: 0.16
Coefficient of linear thermal expansion		
Test method	DIN 53752 -	ASTM D696
Unit of measurement	m/(m °C)	m/(m °C)
Value	Valves/fittings: 5.6 x 10 ⁻⁵ Pipes: 6.6 x 10 ⁻⁵	Valves/fittings: 5.6 x 10 ⁻⁵ Pipes: 6.6 x 10 ⁻⁵
Limiting Oxygen Index		
Test method	ISO 4859-1	ASTM D2863
Unit of measurement	%	%
Value	Valves/fittings: 60 Pipes: 60	Valves/fittings: 60 Pipes: 60

Main properties

PVC-C

Properties of PVC-U		Benefits
Thermal resistance		<ul style="list-style-type: none"> • Service range 0–100 °C (see pressure/temperature regression curve)
Low surface roughness		<ul style="list-style-type: none"> • High flow coefficients (extremely smooth internal walls) • Pressure drop constant over time • Low risk of stoppages due to scaling • Reduced transfer of material to the transported fluid
Chemical resistance		<ul style="list-style-type: none"> • Excellent chemical resistance for conveying corrosive fluids (generally inert to inorganic acids and bases, aromatic and aliphatic hydrocarbons, organic acids, alcohols and halogenated solvents)
Abrasion resistance		<ul style="list-style-type: none"> • Extremely low operating costs due to its long service life
Insulating		<ul style="list-style-type: none"> • Non-conductive (immune to galvanic corrosion) • No condensation problems • Minimum heat loss
Linear thermal expansion coefficients		<ul style="list-style-type: none"> • Reduced need for supports and expansion joints, resulting in considerable advantages in terms of plant design
Easy to join (solvent weld sockets)		<ul style="list-style-type: none"> • Reduced installation costs thanks to the “solvent weld” joint effected using a suitable solvent cement
Fire behaviour		<ul style="list-style-type: none"> • More resistant to combustion than the more commonly used thermoplastics, also due to the presence of self-extinguishing chlorine
Good mechanical resistance		<ul style="list-style-type: none"> • PVC-C satisfies the need to provide adequate mechanical strength and complies with the requirements of industrial plant design

PP-H

General characteristics

Polypropylene is a thermoplastic and partially crystalline resin belonging to the family of polyolefins. PP is obtained through the polymerization of propylene (C₃H₆) with the aid of catalysts. For use in piping systems, the latest-generation Polypropylene Homopolymer variant, or PP-H, offers excellent performance at working temperatures of up to 100° C and a high resistance to chemicals due to the excellent physical and thermal characteristics of the resin.

The PP-H line in latest-generation Polypropylene Homopolymer consists of a comprehensive range of pipes, fittings and valves for use in the construction of process and service lines for conveying pressurised industrial fluids and for maximum operating temperatures of up to 100° C.

The entire line is made of Polypropylene Homopolymer resins MRS 100 (PP-H 100) according to the classification DIN 8077-8078, DIN 16962 and approved by DIBt - Deutsches Institut für Bautechnik for use in industrial processes.









The main properties of the latest-generation Homopolymer resins are:

- **High chemical resistance:** In addition to ensuring excellent chemical resistance, especially against halogens and alkaline solutions, the use of PP-H resins with special additives also ensures excellent mechanical properties when conveying detergents and similar chemicals. PP-H resins are also fully compatible with the transport of drinking, unconditioned, demineralised and spa water for therapeutic and kinotherapeutic uses.
- **Excellent thermal stability:** Particularly in the intermediate temperature range between 10° C and 80° C typical of industrial applications, PP-H ensures excellent mechanical strength and impact resistance with high safety factors.
- **Resistance to ageing:** PP-H resins have a high circumferential breaking strength (Minimum Required Strength MRS \geq 10.0 MPa at 20°C) and allow long installation lifetimes without showing any signs of significant physical-mechanical deterioration.

Density	
Test method	ISO 1183
Unit of measurement	g/cm ³
Value	Valves/fittings/pipes: 0.9
Fluidity index (MFI 190° C, 5 kg)	
Test method	ISO 1133
Unit of measurement	g/(10 min)
Value	Valves/fittings/pipes: 0.5
Modulus of elasticity	
Test method	ASTM D 790
Unit of measurement	MPa = N/mm ²
Value	Valves/fittings/pipes: 1300
IZOD notched impact strength at 23°C	
Test method	ASTM D256
Unit of measurement	J/m
Value	Valves/fittings/pipes: 150
Ultimate elongation	
Test method	ISO 527
Unit of measurement	%
Value	Valves/fittings/pipes: >50
Rockwell hardness	
Test method	ASTM D 785
Unit of measurement	R
Value	Valves/fittings/pipes: 100
Tensile strength	
Test method	ISO 527
Unit of measurement	MPa = N/mm ²
Value	Valves/fittings/pipes: 30
Heat distortion temperature HDT (0.46 N/mm²)	
Test method	ASTM D648
Unit of measurement	°C
Value	Valves/fittings/pipes: 96
Thermal conductivity at 20° C	
Test method	DIN 5216
Unit of measurement	W/(m °C)
Value	Valves/fittings/pipes: 0.22
Coefficient of linear thermal expansion	
Test method	DIN 53752
Unit of measurement	m/(m °C)
Value	Valves/fittings/pipes: 16 x 10 ⁻⁵
Limiting Oxygen Index	
Test method	ASTM D2863
Unit of measurement	%
Value	Valves/fittings/pipes: 17.5
Surface electrical resistivity	
Test method	ASTM D257
Unit of measurement	ohm
Value	Valves/fittings/pipes: >10 ¹³
Flammability	
Test method	UL94
Value	94-HB

Main properties

PP-H

Properties of PP-H		Benefits
Thermal resistance		<ul style="list-style-type: none"> • Service range 0–100 °C (see pressure/temperature regression curves)
Low surface roughness		<ul style="list-style-type: none"> • High flow coefficients (extremely smooth internal walls) • Pressure drop constant over time • Low risk of stoppages due to scaling • Reduced transfer of material to the transported fluid
Chemical resistance		<ul style="list-style-type: none"> • Suitable for conveying chemicals (excellent results with salts and highly alkaline solutions)
Abrasion resistance		<ul style="list-style-type: none"> • Extremely low operating costs due to its long service life
Insulating		<ul style="list-style-type: none"> • Non-conductive (immune to galvanic corrosion) • No condensation problems • Minimum heat loss
Non-toxic		<ul style="list-style-type: none"> • Physiologically safe • Environmental compatibility
Easy jointing (hot socket, butt and electrofusion welding, flanging and threading)		<ul style="list-style-type: none"> • Low installation costs • Wide range of connection possibilities with Accessories and equipment
Low specific weight		<ul style="list-style-type: none"> • Low transport costs • Ease of handling and installation

PVDF

General characteristics

PVDF (polyvinylidene difluoride) is a semi-crystalline fluorinated technopolymer and 59% of its weight is Fluorine.

This material is obtained through the polymerization of vinylidene fluoride. It boasts exceptional mechanical, physical and chemical resistance, guaranteeing excellent performance in terms of thermal stability up to temperatures of 140°C.

The FIP PVDF line uses Solef® PVDF resins (manufactured by SOLVAY) especially formulated for industrial applications, for the production of pipes, fittings and valves made by extrusion and injection moulding.

The entire line is made using Solef® resins by SOLVAY S.A. classified according to ASTM D 3222 and complying with the requirements of ISO 10931.

Thanks to its high purity and exceptional performance, PVDF is the best alternative to metal materials, and is extensively used in industrial applications (chemical, oil, pharmaceutical, pulp and paper, electronic, etc.), whether in process systems or otherwise.

Among the most important properties and advantages of Solef® PVDF, the following are particularly worthy of note:

- **Excellent thermal stability:** the use of Solef® resin, a vinylidene fluoride polymer, ensures excellent resistance to corrosion and abrasion when conveying highly aggressive chemicals. PVDF is basically inert to most inorganic acids and bases, organic acids, aromatic and aliphatic hydrocarbons, alcohols and halogenated solvents. However, it is not recommended for use with fluorine, amines, ketones and oleum (sulfuric acid with sulfur trioxide).

- **Excellent thermal stability:** PVDF maintains its characteristics unchanged in a temperature range between -40° C and +140° C. PVDF pipes are particularly suitable in all applications requiring high operating temperatures, very low levels of fluid contamination and high resistance to ageing due to atmospheric agents and UV radiation.

The material's excellent mechanical properties are retained even at high temperatures.

- **Fire resistance:** Solef® resins guarantee excellent fire resistance without the need for flame retardants (Limit Oxygen Index, LOI = 44%).

In case of combustion, smoke emissions are moderated.

Solef® PVDF resins are classified UL-94, class V-O.

- **Purity:** Solef® PVDF resin is an extremely pure polymer that does not contain stabilizers, plasticizers, lubricants or flame retardants.







As a result, it is the ideal material for conveying ultra-pure water and chemicals, ensuring the non-contamination of the conveyed fluid. As it is physiologically non-toxic, it is suitable for conveying fluids and food products.

- **High abrasion resistance:** according to the Taber Abrasion Test (in which the weight loss of a material is measured after being exposed to an abrasive wheel for 1000 cycles), PVDF is the most resistant thermoplastic material (CS-10 Load 1kg - Weight Loss / 1000 cycles = 5-10 mg.)

Density		
Test method	ISO 1183	
Unit of measurement	g/cm ³	
Value	Valves/fittings: 1.78 - Pipes: 1.78	
Fluidity index (MFI 230° C, 5 kg)		
Test method	ISO 1133	ASTM D1238
Unit of measurement	g/(10 min)	g/(10 min)
Value	Valves/fittings: 6 - Pipes: 6	Valves/fittings: 24 - Pipes: 24
Modulus of elasticity		
Test method	ISO 527	ASTM D1238
Unit of measurement	MPa = N/mm ²	MPa = N/mm ²
Value	Valves/fittings: 2100 - Pipes: 2100	Valves/fittings: 2200 - Pipes: 2100
IZOD notched impact strength at 23°C		
Test method	ASTM D256	
Unit of measurement	J/m	
Value	Valves/fittings: 55 - Pipes: 110	
Ultimate elongation		
Test method	ISO 527-2	ASTM D 638
Unit of measurement	%	%
Value	Valves/fittings: 80 - Pipes: 80	Valves/fittings: 5-10 - Pipes: 20-50
Rockwell hardness		
Test method	ASTM D 785	
Unit of measurement	R	
Value	Valves/fittings: 110 - Pipes: 110	
Tensile strength		
Test method	ISO 527	ASTM D 638
Unit of measurement	MPa = N/mm ²	MPa = N/mm ²
Value	Valves/fittings: 50 - Pipes: 50	Valves/fittings: 53-57 - Pipes: 53-57
Heat distortion temperature HDT (0.46 N/mm²)		
Test method	ISO 75	ASTM D 648
Unit of measurement	°C	°C
Value	Valves/fittings: 145 - Pipes: 145	Valves/fittings: 148 - Pipes: 147
Thermal conductivity at 23° C		
Test method	DIN 52612-1	ASTM C 177
Unit of measurement	W/(m K)	W/(m K)
Value	Valves/fittings: 0.20 - Pipes: 0.20	Valves/fittings: 0.20 - Pipes: 0.20
Coefficient of linear thermal expansion		
Test method	DIN 53752	ASTM D 696
Unit of measurement	m/(m °C)	m/(m °C)
Value	Valves/fittings: 12x10 ⁻⁵ Pipes: 12x10 ⁻⁵	Valves/fittings: 12x10 ⁻⁵ Pipes: 12x10 ⁻⁵
Limiting Oxygen Index		
Test method	ISO 4859-1	ASTM D 2863
Unit of measurement	%	%
Value	Valves/fittings: 44 - Pipes: 44	Valves/fittings: 44 - Pipes: 44
Surface electrical resistivity		
Test method	ASTM D257	
Unit of measurement	ohm	
Value	Valves/fittings: >10 ¹⁴ - Pipes: >10 ¹⁴	
Flammability		
Test method	UL94	
Value	V-0	

Main properties

PVDF

Properties of PVDF		Benefits
Thermal resistance		<ul style="list-style-type: none"> • Operating range: – 40 +140°C (see pressure/temperature regression curves)
Low surface roughness		<ul style="list-style-type: none"> • High flow coefficients (extremely smooth internal walls)
Chemical resistance		<ul style="list-style-type: none"> • Excellent chemical resistance for conveying corrosive fluids (generally inert to inorganic acids and bases, aromatic and aliphatic hydrocarbons, organic acids, alcohols and halogenated solvents)
Abrasion resistance		<ul style="list-style-type: none"> • Extremely low operating costs due to its long service life
Fully recyclable and non-toxic		<ul style="list-style-type: none"> • Physiologically safe
Easy jointing (hot socket, butt and electrofusion welding, flanging and threading)		<ul style="list-style-type: none"> • Low installation costs
Excellent mechanical properties		<ul style="list-style-type: none"> • PVDF responds to the need to provide suitable mechanical resistance meeting the design requirements of industrial plants

REFERENCE STANDARDS, APPROVALS, AND QUALITY MARKS

ACTUATED VALVES



Reference standards

Production of the FIP valves is carried out according to the highest quality standards and in full compliance with the environmental restrictions set by the applicable laws in force and in accordance with **ISO 14001**.

All products are made in accordance with the quality guarantee system in compliance with **ISO 9001**.

- **ANSI B16.5**
Pipe flanges and flanged fittings–NPS 1/2 to NPS 24 mm / inch
- **ASTM D 1784 cl. 23548B**
Rigid PVC and PVC-C compounds (for industrial applications)
- **ASTM D 2464**
Standard Specification for Threaded Poly Vinyl Chloride (PVC) Plastic Pipe Fittings
- **ASTM D 2467**
Standard Specification for Poly Vinyl Chloride (PVC) Plastic Pipe Fittings, Schedule 80
- **ASTM D 3222**
PVDF, material for extrusion moulding and coating
- **ASTM D 4101-06**
Polypropylene compound according to the classification PP0110B56000
- **ASTM F437**
PVC-C threaded pipe fittings, sch. 80
- **ASTM F439**
PVC-C pipe fittings
- **BS 10**
Specification for flanges and bolts for pipes, valves and fittings
- **BS 1560**
Flanges for pipes, valves and fittings (Class designated). Flange in Steel, cast iron and copper alloy. Specification for steel flanges
- **BS 4504**
Flanges for pipes, valves and fittings (PN designated).
- **DIN 2501**
Flanges, dimensions
- **DIN 2999**
Whitworth thread for threaded pipes and fittings
- **DIN 3202**
Overall valve dimensions
- **DIN 3441-2**
Dimensions of PVC-U ball valves
- **DIN 8063**
Dimensions of PVC-U and PVC-C fittings
- **DIN 16962**
PVC-C, PP-H and PVDF fittings for socket and butt welding
- **DIN 16963**
Pipe joints and pipe components for pressurised fluids in HDPE
- **DVS 2202-1**
Imperfections of PP-H and PVDF welded joints, characteristics, descriptions and evaluations
- **DVS 2204 - 2221**
Solvent welding of thermoplastic materials
- **DVS 2207-11**
Socket and butt welding of PP-H components
- **DVS 2207-15**
Welding of components in PVDF
- **DVS 2208-1**
Machinery and equipment for thermocouple welding pipes, pipe parts and panels.
- **EN 558**
Industrial valves - Overall dimensions of metal valves for use in flanged pipe systems - PN designated valves
- **EN 1092-1**
Flanges and their joints - Circular flanges for pipes, fittings, valves and accessories - Part 1: Steel flanges, PN designated

- **EN 60529**
Casing protection classes
- **EN ISO 1452**
Characteristics of fittings and pipes in PVC-U for piping systems intended for water supply
- **EN ISO 10931**
Specifications for components (Pipes, Fittings and Valves) in PVDF for industrial applications
- **EN ISO 15493**
Specifications for components and the system (Pipes, Fittings and Valves) in ABS, PVC-U, PVC-C for industrial applications
- **EN ISO 15494**
Specifications for components (Pipes, Fittings and Valves) in PP-H for industrial applications
- **EN ISO 16135**
Industrial valves - Ball valves of thermoplastic material
- **EN ISO 16136**
Industrial valves - Butterfly valves of thermoplastic material
- **EN ISO 16137**
Industrial valves - Check valves of thermoplastic material
- **EN ISO 16138**
Industrial valves - Diaphragm valves of thermoplastic material
- **ISO 7**
PVC-U fittings with threaded connections for pressure-tight threaded joints
- **ISO 161-1**
Dimensions of PVC-U pipes and fittings - metric series
- **ISO 228-1**
PVC-U and PVC-C fittings with threaded connections
- **ISO 727**
PVC-U pipes and fittings Dimensions and tolerances, metric series
- **ISO 5211**
Part-turn actuator couplings
- **ISO 5752**
Metal valves for use in flanged pipe systems; overall dimensions
- **ISO 7005-1**
Metal flanges; part 1: steel flanges
- **ISO 9393**
Thermoplastics valves - pressure test methods and requirements
- **JIS B 2220**
Flanges for metal pipes
- **JIS K 6743**
Polyvinyl chloride (PVC-U) pipe fittings for water supply
- **UNI 11242**
Solvent welding of PVC-U pipes, fittings and valves
- **UNI 11318**
Socket welding of PP-H components
- **UNI 11397**
Butt welding of PP-H components
- **VDI/VDE 3845 (NAMUR)**

Approvals and quality marks



- **ACS**

FIP PVC-U and PVC-C ball and butterfly valves are certified as suitable for coming into contact with water intended for human consumption according to the Attestation de conformité sanitaire (ACS)



- **DIBt**

VKD FIP PP-H and PVDF valves have been tested and certified by DIBt (Deutsches Institut für Bautechnik)



- **EAC**

FIP PVC-U valves are EAC certified in accordance with Russian regulations on Safety, Hygiene and Quality



- **NSF**

Ball, butterfly and SXE valves (where applicable) in PVC-U, PVC-C and PP-H are listed according to the NSF/ANSI Standard 61 - Drinking Water System Components - Health Effects.



- **UKR SEPRO**

FIP valves are certified in accordance with Ukrainian regulations on Safety and Quality



- **WRAS**

Resins used for FIP PVC-U and PVC-C valves are recognised by the WRAS (Water Regulation Advisory Scheme - UK)

- **KTW-W270**

The resin used for PVC-U valves is certified as suitable to come into contact with water intended for human consumption as per Deutscher Verein des Gas und Wasserfaches



- **NIZP**

FIP valves (in PVC-U and PP-H) are recognised as suitable for drinking water conveyance by the NIZP (National Institute of Public Health - Poland)



- **FDA**

Suitability of resins used for valves in PP-H and PVDF for food contact. Resins used for PVC-U and PVC-C valves considered "prior sanction" by the FDA.



FE/CE - FE/CP DN 40÷200

PVC-U

ELECTRICALLY OR PNEUMATICALLY ACTUATED
BUTTERFLY VALVE



FE/CE – FE/CP DN 40÷200

The FE is a butterfly valve for shutting off or regulating flow, specifically designed for water conveyance applications.

ELECTRICALLY OR PNEUMATICALLY ACTUATED BUTTERFLY VALVE

- Disk in PVC-U with through shaft
- **Zinc plated square section steel stem completely isolated from the fluid** complying with standard ISO 5211:
 - DN 40 ÷ 65: 11 mm
 - DN 80 ÷ 100: 14 mm
 - DN 125 ÷ 150: 17 mm
 - DN 200: 22 mm
- Can also be installed as an end line valve, bottom discharge valve or tank dump valve
- **Valve material compatibility** (PVC-U) with water conveyance, drinking water and other food substances according to **current regulations**
- Possibility of directly installing pneumatic and/or electric actuators with a standard drilling pattern according to standard ISO 5211 F05, F07, F10

Technical specifications - FE

Construction	Bi-directional centric butterfly valve
Size range	DN 40 ÷ 200
Nominal pressure	DN 40 ÷ 50: PN16 with water at 20° C DN 65÷200: PN 10 with water at 20° C
Temperature range	0 °C ÷ 60 °C
Coupling standards	Flanging system: EN ISO 1452, EN ISO 15493, DIN 2501, ISO 7005-1, EN 1092-1, ASTM B16.5 Cl.150, JIS B2220
Reference standards	Construction criteria: EN ISO 16136, EN ISO 1452, EN ISO 15493 Test methods and requirements: ISO 9393 Actuator couplings: ISO 5211
Valve material	Body: PVC-U Disk: PVC-U Stem: Zinc plated carbon steel (C45). On request STAINLESS steel AISI 316
Seal material	Liner: EPDM, FKM
Control options	Pneumatic actuator, electric actuator

In addition to the manually actuated version, FE is also available in FE/ CE electrically actuated and FE/CP pneumatically actuated configurations.

FE/CD and FE/CP are constructed with actuators meeting current regulations and selected by FIP according to their quality and reliability requirements. The efficiency of these valves, tested according to the company's quality standards, is guaranteed by the expertise and know-how that FIP dedicates to manufacturing its products.

Technical specifications - Electric actuator	
Reference standards	Construction criteria: Electromagnetic compatibility EMC 2004/108/CE. Low voltage directive 2006/95/CE. Machinery directive 2006/42/CE. R.O.H.S. directive 2011/65/CE Coupling for valves: ISO 5211; DIN 3337
Actuator material	Plastic parts: PA6,6 30% and Nylon. Metallic parts: 304L stainless steel or steel + zinc plating (DN40-100); Aluminium + EPOXY paint (DN125-200)
Supply Voltage	12V DC* - 24V AC/DC - 90-240V AC - 400V three phase* *voltages available upon request
Temperature range	From -10 °C to +55 °C
Standard equipment	<ul style="list-style-type: none"> • Manual safety override • Visual position indicator • Two auxiliary limit switches (5A) adjustable FC1, FC2 • Torque limiter • Anti-condensation heating element (IP66-IP67) (DN125-200)
Accessories	<ul style="list-style-type: none"> • Positioner board 4-20 mA or 0-10V DC • Fail Safe unit • Anti-condensation heating element (DN40-100) • Feedback potentiometer 100 - 1000 - 5000 - 10000 Ohm • 4-20 mA position transmitter • Kit with additional pair of auxiliary limit switches
Special versions upon request	<ul style="list-style-type: none"> • CEI34 50% service • Protection class IP68 or ATEX II 2 GD EEx d IIB T6 • Different operating times
Electrical connection	<ul style="list-style-type: none"> • Power supply: connector DIN 43650 3P + GND (DN 40-100); cable gland ISO M20 (DN 125-200) • Limit switch: Cable gland ISO M20

Technical specifications - Pneumatic actuator	
Reference standards	Construction criteria: Machinery directive 2006/42/CE R.O.H.S. directive 2011/65/CE EN 15714-3 Coupling for valves: ISO 5211, DIN 3337 Compressed air connections: NAMUR VDI/VDE-3845 Top connections for accessories: NAMUR VDI/VDE-3845
Actuator material	Body: hard coat anodised extruded aluminium. IP67 Bonnet: polyester powder painted aluminium alloy Pinion: nickel-plated carbon steel Other materials available upon request
Control air pressure	From 5 to 8 bar. Pmax= 10 bar Reduced control pressure executions available upon request
Power supply	Dry or lubricated filtered compressed air. If using other fluids, contact the FIP service centre
Temperature range	From -20 °C to +80 °C
Accessories	<ul style="list-style-type: none"> • Optical position indicator • LSQT electromechanical and PNP inductive limit switch boxes (Namur upon request) • Electric-pneumatic positioner 4-20 mA • 3-5/2 way pilot solenoid valves
Available options	Body and bonnet with PTFE, AISI 316 or AISI 316 coating with mirror polishing. 304 or 316 stainless steel pinion.

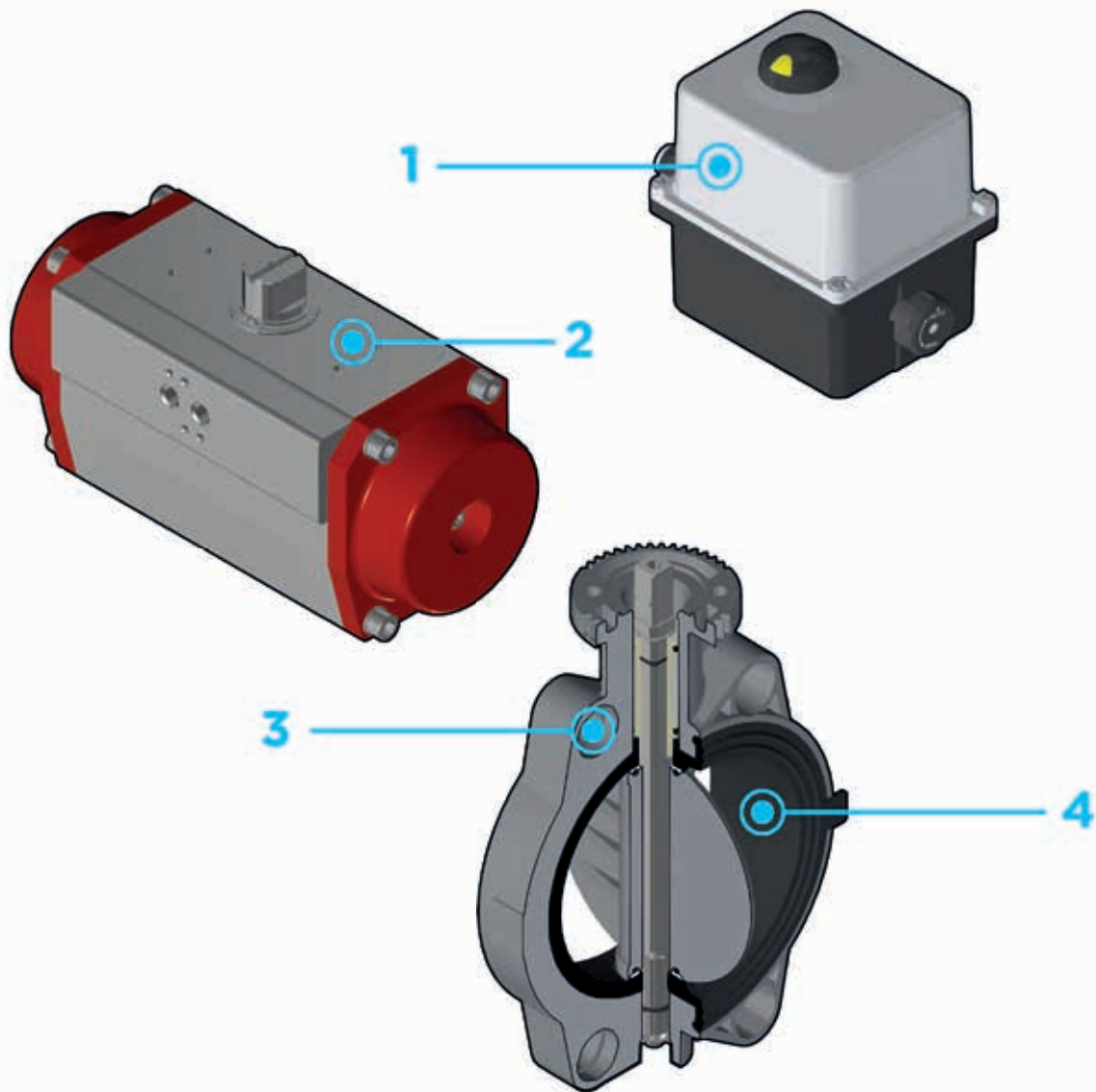

1 Electric actuator constructed according to FIP specifications; with plastic shell and standard emergency override. Available with voltages from 12 to 240V.

2 Rack & pinion type pneumatic actuator constructed according to FIP specifications: fully protected

against weather corrosion available in double-acting (DA) or simple-acting normally closed (NC) or normally open (NO) versions.

3 **Drilling pattern with oval slots** that allow coupling to flanges according to numerous international standards.

4 **Interchangeable liner** with the dual function of forming a hydraulic seal and isolating the body from the fluid.

TECHNICAL DATA

PRESSURE VARIATION ACCORDING TO TEMPERATURE

PVC-U BODY

For water and non-hazardous fluids with regard to which the material is classified as CHEMICALLY RESISTANT. In other cases, a reduction of the nominal pressure PN is required (25 years with safety factor).

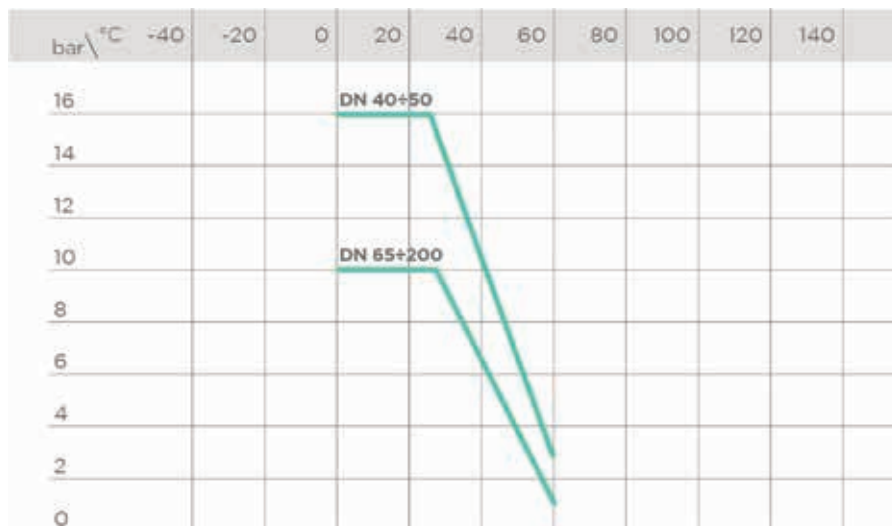

PRESSURE DROP GRAPH

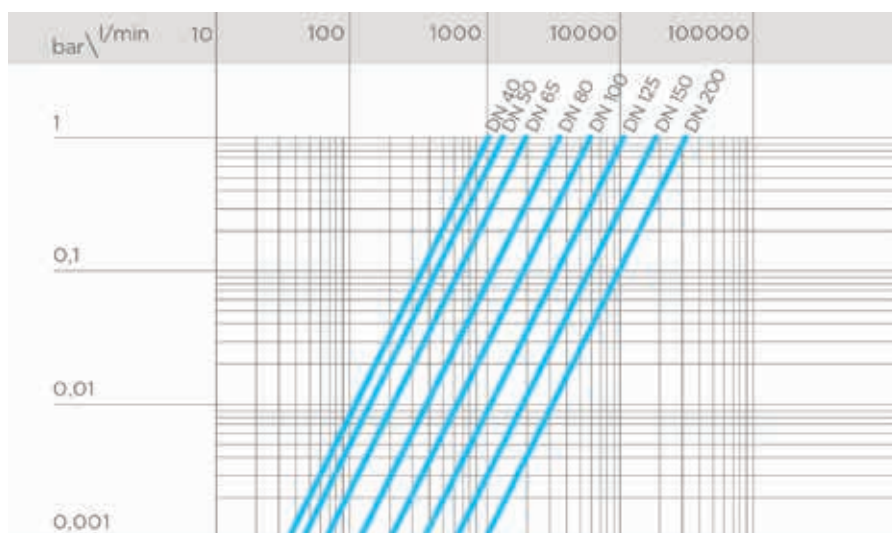

K_v100 FLOW COEFFICIENT

The K_v100 flow coefficient is the Q flow of litres per minute of water at a temperature of 20°C that will generate Δp= 1 bar pressure drop at a certain valve position.

The K_v100 values shown in the table are calculated with the valve completely open.

DN	40	50	65	80	100	125	150	200
Kv100 l/min	1000	1285	1700	3550	5900	9850	18700	30500

RELATIVE FLOW COEFFICIENT GRAPH

The relative flow coefficient is the flow rate through the valve as a function of the degree of valve opening.

X axis: Percentage opening of the disk

Y axis: Relative flow coefficient

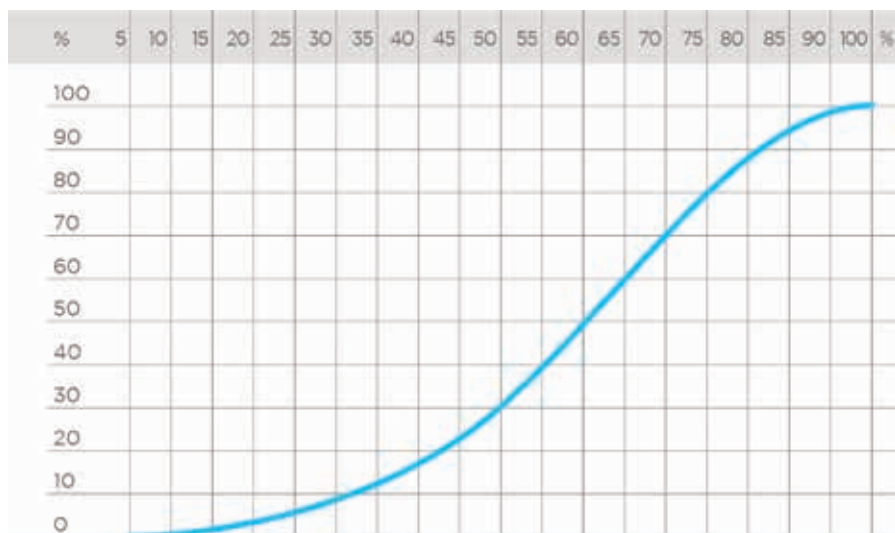

ELECTRIC ACTUATOR DATA

DN40÷65 FUNCTIONAL CHARACTERISTICS

Characteristics	DC	AC/DC	AC
Power supply	*12V	24V	90÷240V
Power	15W	15W	15W
Max operating time	11 s	12 s	13 s
IEC34 service	50%	30%	30%
Protection class	IP66	IP65	IP65
Frequency	-	50/60 Hz	50/60 Hz

DN80÷100

Characteristics	DC	AC/DC	AC
Power supply	*12V	24V	90÷240V
Power	45W	45W	45W
Max operating time	12 s	13 s	15 s
IEC34 service	50%	30%	30%
Protection class	IP66	IP65	IP65
Frequency	-	50/60 Hz	50/60 Hz

DN125÷150

Characteristics	AC/DC	AC
Power supply	24V	90÷240V
Power	85W	85W
Max operating time	30 s	30 s
IEC34 service	50%	50%
Protection class	IP67	IP67
Frequency	50/60 Hz	50/60 Hz

DN200

Characteristics	AC/DC	AC
Power supply	24V	90÷240V
Power	85W	85W
Max operating time	50 s	50 s
IEC34 service	50%	50%
Protection class	IP67	IP67
Frequency	50/60 Hz	50/60 Hz

DN 40-100 POWER CONNECTION DIAGRAM

- 1 Shared
- 2 Open
- 3 Closed

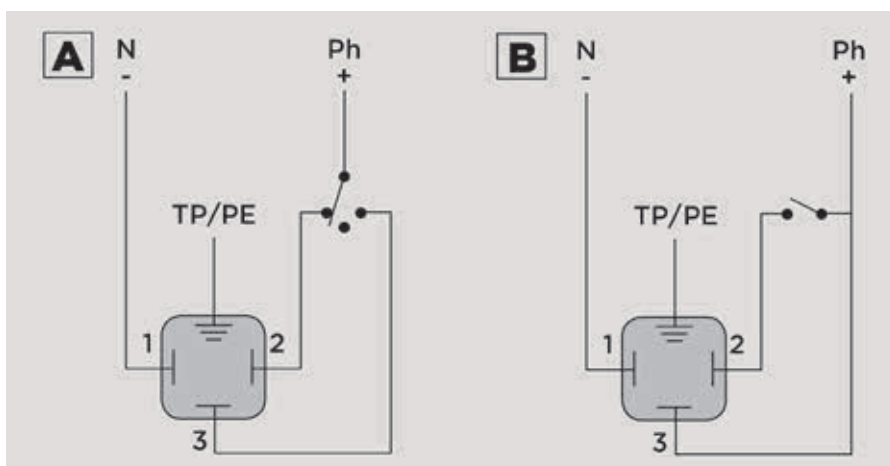

DN 125-200 POWER CONNECTION DIAGRAM

- 1 Shared
- 2 Open
- 3 Closed

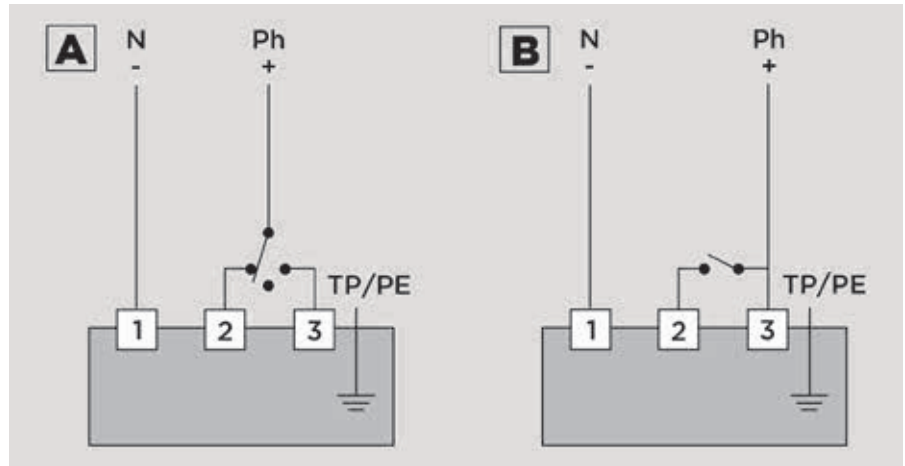

DN40-200 AUXILIARY LIMIT SWITCH CONNECTION DIAGRAM

- FC1 Open auxiliary limit switch
- FC2 Close auxiliary limit switch

- 4 Shared FC1
- 5 Open FC1
- 6 Shared FC2
- 7 Open FC2
- 8 Close FC1
- 9 Close FC2

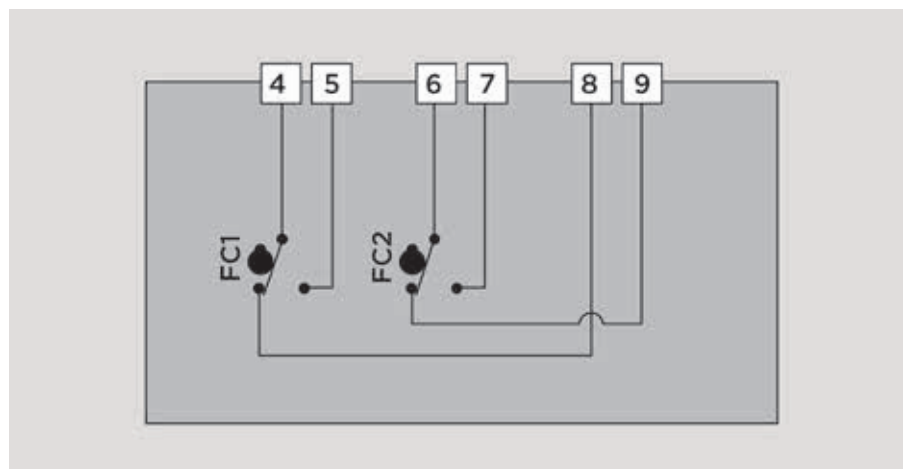

PNEUMATIC ACTUATOR DATA

FUNCTIONAL CHARACTERISTICS

Function type	double-acting	Normally closed (NC)	Normally Open (NO)
Valve opening	air	air	spring
Valve closing	air	spring	air

ACTUATOR CAPACITY

L: litre, equivalent to 10^{-3} m^3

Air consumption in normal litres (or normal cubic metres) per operating cycle can be calculated by correcting according to operating conditions such as control air pressure.

DN	40	50	65	80	100	125	150	200
DA	0.45 L	0.45 L	0.45 L	0.61 L	0.98 L	0.98 L	1.8 L	2.8 L
SA (NC-NO)	0.18 L	0.244 L	0.244 L	0.302 L	0.72 L	1.12 L	1.12 L	3.2 L

COMPRESSED AIR CONNECTIONS

Function type	Double-acting (DA)	Normally closed (NC)	Normally Open (NO)
Valve opening	Inlet A	Inlet A	-
Valve closing	Inlet B	-	Inlet A

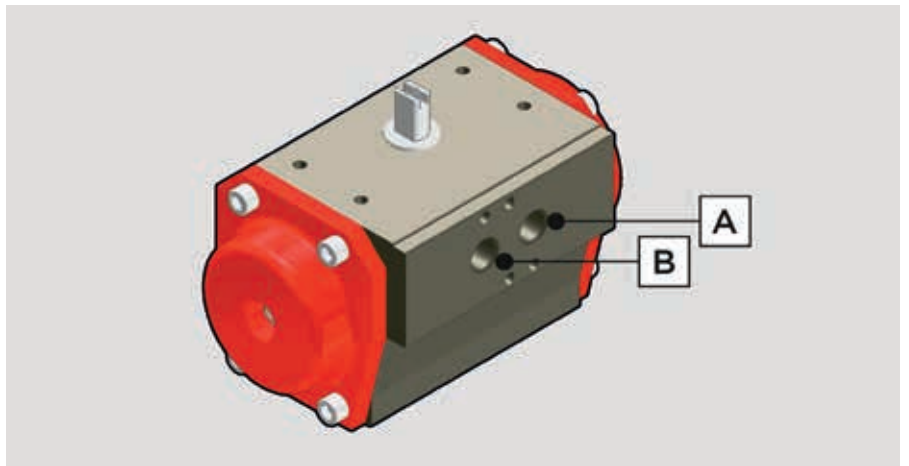

DIMENSIONS

FE/CE DN 40÷200 PVC-U

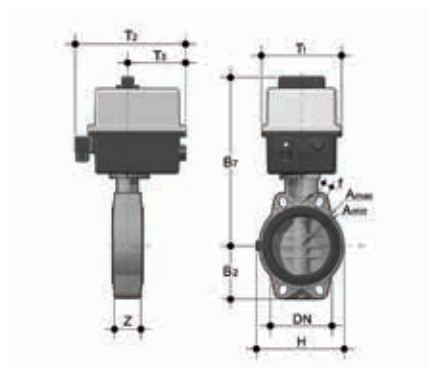

FEOV/CE 90-240V AC DN 40-100

Butterfly valve with multi-volt electric actuator 90-240 V AC 50-60 Hz

d	DN	PN	B ₂	H	Z	A _{min}	A _{max}	f	U	B ₇	T ₁	T ₂	T ₃	g	EPDM Code	FKM Code
50-1 1/2"	40	16	60	132	33	93.5	109	19	4	253	92	187	91	2074	FEOVEM050E	FEOVEM050F
63-2"	50	16	70	147	43	108	124	19	4	259	92	187	91	2254	FEOVEM063E	FEOVEM063F
75-2 1/2"	65	10	80	165	46	128	144	19	4	266	92	187	91	2480	FEOVEM075E	FEOVEM075F
90-3"	80	10	90	130	49	145	159	19	4	308	128	202	95.5	4000	FEOVEM090E	FEOVEM090F
110-4"	100	10	105	150	56	165	190	19	4	322	128	202	95.5	4350	FEOVEM110E	FEOVEM110F



FEOV/CE 90-240V AC DN 125-150

Butterfly valve with multi-volt electric actuator 90-240 V AC 50-60 Hz

d	DN	PN	B ₂	H	Z	A _{min}	A _{max}	f	U	B ₇	g	EPDM Code	FKM Code
*125/140-5"	125	10	121	185	64	204	215	23	4	425	8100	FEOVEM140E	FEOVEM140F
160-6"	150	10	132	210	70	230	242	23	4	438	8800	FEOVEM160E	FEOVEM160F

*FEOV d140 with special adapter collars d125

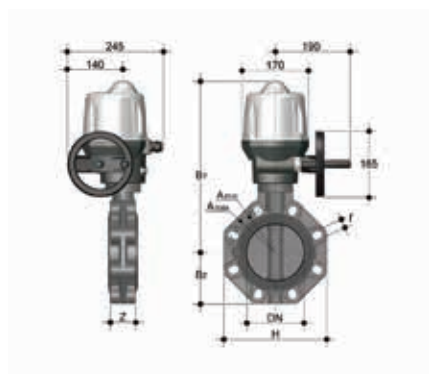

FEOV/CE 90-240V AC DN 200

Butterfly valve with multi-volt electric actuator 90-240 V AC 50-60 Hz

d	DN	PN	B ₂	H	Z	A _{min}	A _{max}	f	U	B ₇	g	EPDM Code	FKM Code
**200/225-8"	200	10	161	325	71	280	298	23	8	485	11560	FEOVEM225E	FEOVEM225F

**FEOV d225 with special adapter collars d200

DIMENSIONS

FE/CE DN 40÷200 PVC-U

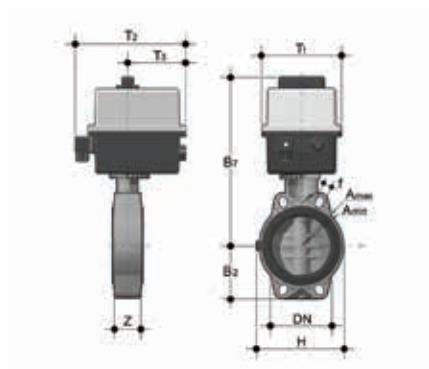

FEOV/CE 24V AC/DC DN 40-100

Butterfly valve with electric actuator 24 V AC/DC

d	DN	PN	B ₂	H	Z	A _{min}	A _{max}	f	U	B ₇	T ₁	T ₂	T ₃	g	EPDM Code	FKM Code
50-1 1/2"	40	16	60	132	33	93.5	109	19	4	253	92	187	91	2074	FEOVEL050E	FEOVEL050F
63-2"	50	16	70	147	43	108	124	19	4	259	92	187	91	2254	FEOVEL063E	FEOVEL063F
75-2 1/2"	65	10	80	165	46	128	144	19	4	266	92	187	91	2480	FEOVEL075E	FEOVEL075F
90-3"	80	10	90	130	49	145	159	19	4	308	128	202	95.5	4000	FEOVEL090E	FEOVEL090F
110-4"	100	10	105	150	56	165	190	19	4	322	128	202	95.5	4350	FEOVEL110E	FEOVEL110F



FEOV/CE 24V AC/DC DN 125-150

Butterfly valve with electric actuator 24 V AC/DC

d	DN	PN	B ₂	H	Z	A _{min}	A _{max}	f	U	B ₇	g	EPDM Code	FKM Code
*125/140-5"	125	10	121	185	64	204	215	23	4	425	8100	FEOVEL140E	FEOVEL140F
160-6"	150	10	132	210	70	230	242	23	4	438	8800	FEOVEL160E	FEOVEL160F

*FEOV d140 with special adapter collars d125

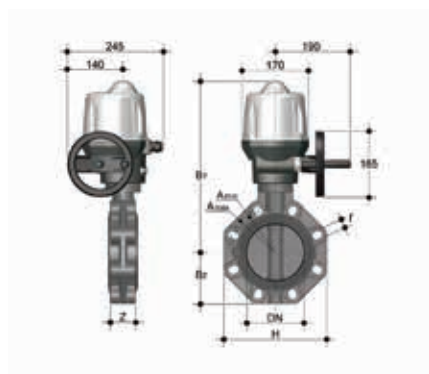

FEOV/CE 24V AC/DC DN 200

Butterfly valve with electric actuator 24 V AC/DC

d	DN	PN	B ₂	H	Z	A _{min}	A _{max}	f	U	B ₇	g	EPDM Code	FKM Code
**200/225-8"	200	10	161	325	71	280	298	23	8	485	11560	FEOVEL225E	FEOVEL225F

*FEOV d225 with special adapter collars d200

DIMENSIONS

FE/CP DN 40÷200 PVC-U

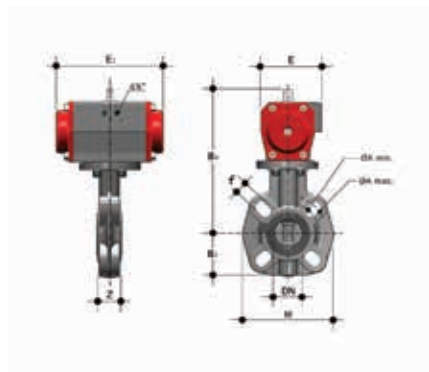

FE/CP DA DN 40-65

Butterfly valve with pneumatic actuator, Double-Acting function

d	DN	PN	B ₂	H	Z	A _{min}	A _{max}	f	U	B ₄	E	E ₁	g	EPDM Code	FKM Code
50-1 1/2"	40	16	60	132	33	93.5	109	19	4	209	86	155	2170	FEOVDA050E	FEOVDA050F
63-2"	50	16	70	147	43	108	124	19	4	215	86	155	2350	FEOVDA063E	FEOVDA063F
75-2 1/2"	65	10	80	165	46	128	144	19	4	222	86	155	2580	FEOVDA075E	FEOVDA075F

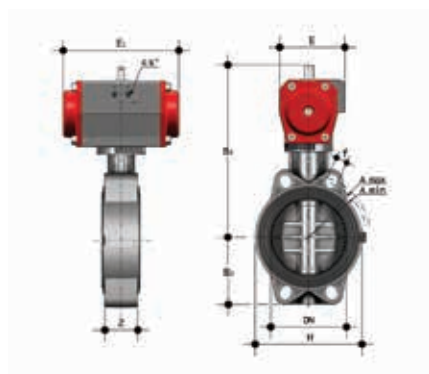

FE/CP DA DN 80-150

Butterfly valve with pneumatic actuator, Double-Acting function

d	DN	PN	B ₂	H	Z	A _{min}	A _{max}	f	U	B ₄	E	E ₁	g	EPDM Code	FKM Code
90-3"	80	10	90	130	49	145	159	19	4	253	94	210	4100	FEOVDA090E	FEOVDA090F
110-4"	100	10	105	150	56	165	190	19	4	277	104	228	5750	FEOVDA110E	FEOVDA110F
*125/140-5"	125	10	121	185	64	204	215	23	4	297	104	228	6700	FEOVDA140E	FEOVDA140F
160-6"	150	10	132	210	70	230	242	23	4	325	120	280	9000	FEOVDA160E	FEOVDA160F

*FEOV d140 with special adapter collars d125

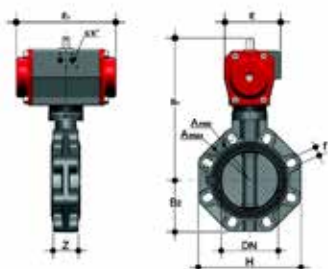

FE/CP DA DN 200

Butterfly valve with pneumatic actuator, Double-Acting function

d	DN	PN	B ₂	H	Z	A _{min}	A _{max}	f	U	B ₄	E	E ₁	g	EPDM Code	FKM Code
**200/225-8"	200	10	161	325	71	280	298	23	8	399	134	310	15150	FEOVDA225E	FEOVDA225F

* FEOV d225 with special adapter collars d200

DIMENSIONS

FE/CP DN 40÷200 PVC-U

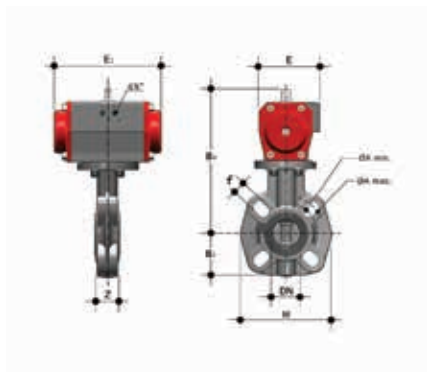

FE/CP NC DN 40-65

Butterfly valve with pneumatic actuator, Normally Closed function

d	DN	PN	B ₂	H	Z	A _{min}	A _{max}	f	U	B ₄	E	E ₁	g	EPDM Code	FKM Code
50-1 1/2"	40	16	60	132	33	93.5	109	19	4	209	86	155	2370	FEOVNC050E	FEOVNC050F
63-2"	50	16	70	147	43	108	124	19	4	232	94	210	4120	FEOVNC063E	FEOVNC063F
75-2 1/2"	65	10	80	165	46	128	144	19	4	239	94	210	4380	FEOVNC075E	FEOVNC075F

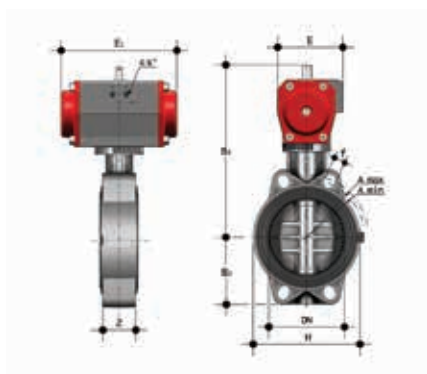

FE/CP NC DN 80-150

Butterfly valve with pneumatic actuator, Normally Closed function

d	DN	PN	B ₂	H	Z	A _{min}	A _{max}	f	U	B ₄	E	E ₁	g	EPDM Code	FKM Code
90-3"	80	10	90	130	49	145	159	19	4	263	104	228	6000	FEOVNC090E	FEOVNC090F
110-4"	100	10	105	150	56	165	190	19	4	292	120	280	8350	FEOVNC110E	FEOVNC110F
*125/140-5"	125	10	121	185	64	204	215	23	4	339	134	310	12800	FEOVNC140E	FEOVNC140F
160-6"	150	10	132	210	70	230	242	23	4	352	134	310	13500	FEOVNC160E	FEOVNC160F

*FEOV d140 with special adapter collars d125

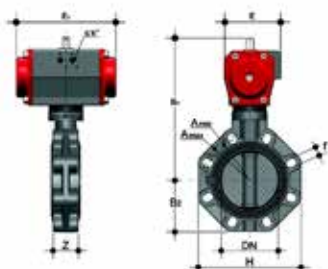

FE/CP NC DN 200

Butterfly valve with pneumatic actuator, Normally Closed function

d	DN	PN	B ₂	H	Z	A _{min}	A _{max}	f	U	B ₄	E	E ₁	g	EPDM Code	FKM Code
**200/225-8"	200	10	161	325	71	280	298	23	8	473	176	462	35250	FEOVNC225E	FEOVNC225F

* FEOV d225 with special adapter collars d200

DIMENSIONS

FE/CP DN 40÷200 PVC-U

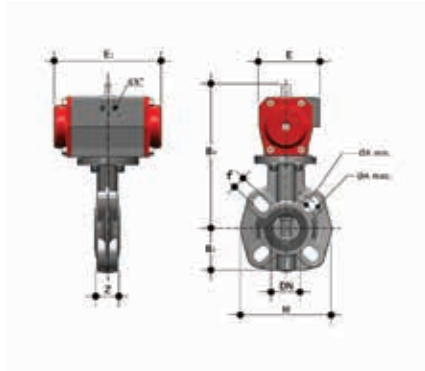

FEOV/CP NO DN 40-65

Butterfly valve with pneumatic actuator, Normally Open function

d	DN	PN	B ₂	H	Z	A _{min}	A _{max}	f	U	B ₄	E	E ₁	g	EPDM Code	FKM Code
50-1 1/2"	40	16	60	132	33	93.5	109	19	4	209	86	155	2370	FEOVNO050E	FEOVNO050F
63-2"	50	16	70	147	43	108	124	19	4	232	94	210	4120	FEOVNO063E	FEOVNO063F
75-2 1/2"	65	10	80	165	46	128	144	19	4	239	94	210	4380	FEOVNO075E	FEOVNO075F

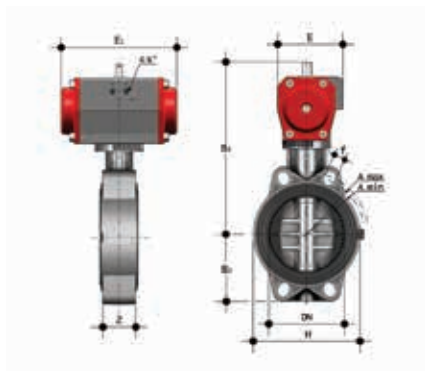

FEOV/CP NO DN 80-150

Butterfly valve with pneumatic actuator, Normally Open function

d	DN	PN	B ₂	H	Z	A _{min}	A _{max}	f	U	B ₄	E	E ₁	g	EPDM Code	FKM Code
90-3"	80	10	90	130	49	145	159	19	4	263	104	228	6000	FEOVNO090E	FEOVNO090F
110-4"	100	10	105	150	56	165	190	19	4	292	120	280	8350	FEOVNO110E	FEOVNO110F
*125/140-5"	125	10	121	185	64	204	215	23	4	339	134	310	12800	FEOVNO140E	FEOVNO140F
160-6"	150	10	132	210	70	230	242	23	4	352	134	310	13500	FEOVNO160E	FEOVNO160F

*FEOV d140 with special adapter collars d125

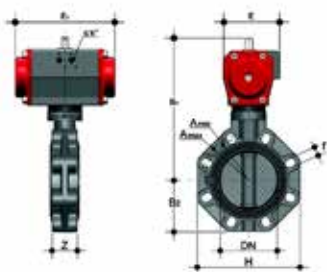

FEOV/CP NO DN 200

Butterfly valve with pneumatic actuator, Normally Open function

d	DN	PN	B ₂	H	Z	A _{min}	A _{max}	f	U	B ₄	E	E ₁	g	EPDM Code	FKM Code
**200/225-8"	200	10	161	325	71	280	298	23	8	473	176	462	35250	FEOVNO225E	FEOVNO225F

* FEOV d225 with special adapter collars d200

COMPONENTS

EXPLODED VIEW DN 40÷65

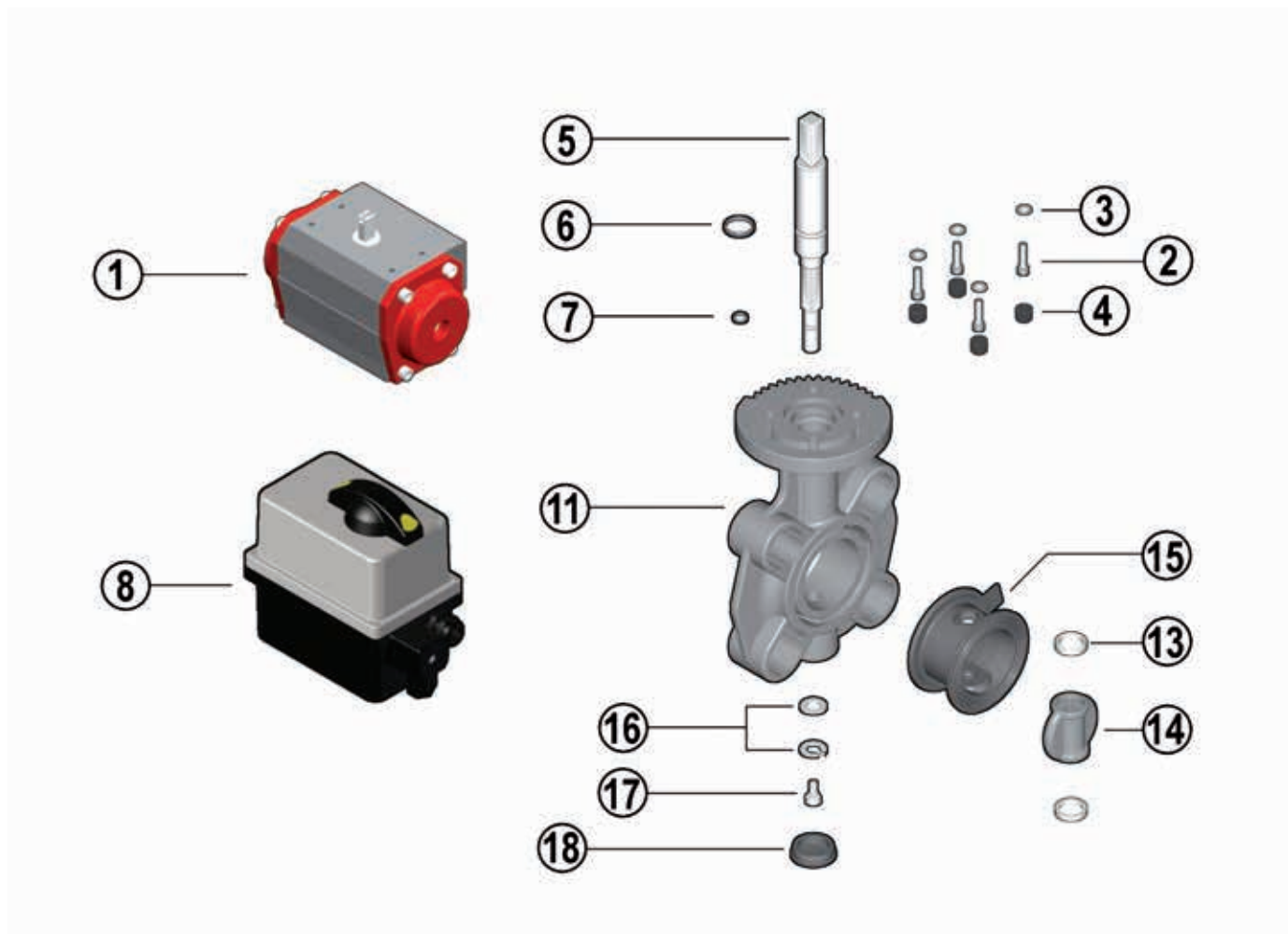

- 1** Pneumatic actuator (Finished aluminium - 1)
- 8** Electric actuator (PA6-Nylon - 1)
- 2** Screw (STAINLESS steel - 4)*
- 3** Washer (STAINLESS steel - 4)*
- 4** Protection plug (PE - 4)*

- 5** Stem (Zinc plated steel - 1)*
- 6** Stem O-Ring (EPDM or FKM - 1)*
- 7** Stem O-Ring (EPDM or FKM - 1)*
- 11** Body (PVC-U - 1)
- 13** Anti-friction ring (PTFE - 2)*
- 14** Disk (PVC-U - 1)*

- 15** Primary gasket (EPDM or FKM - 1)*
- 16** Washer (Steel- 1)
- 17** Screw (STAINLESS steel - 1)
- 18** Protection plug (PE - 1)

* Spare parts

The material the component is made of and the quantity supplied are shown in brackets

EXPLODED VIEW DN 80÷200

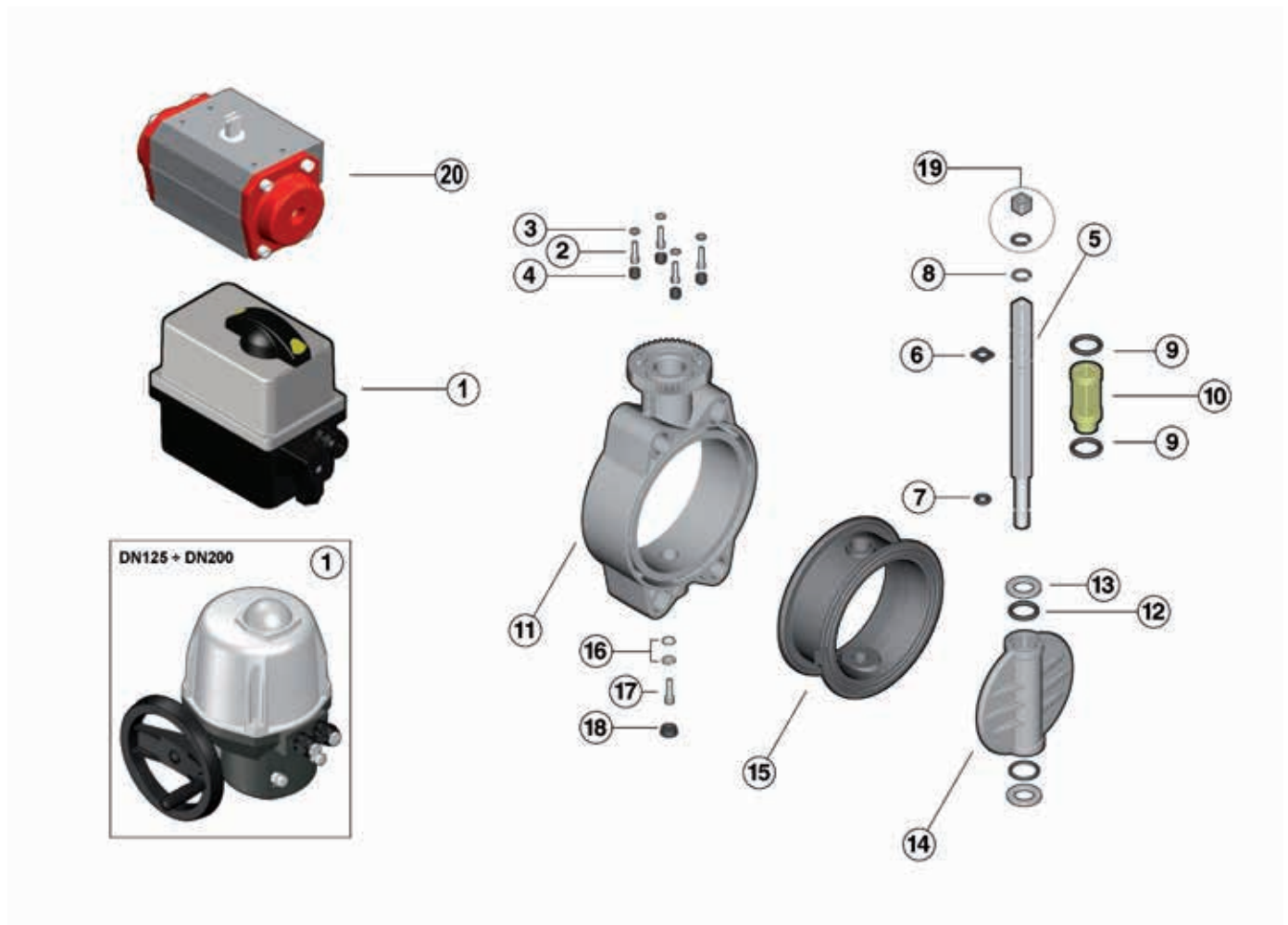

- | | | | | | |
|-----------|--|-----------|-----------------------------------|-----------|--|
| 1 | Electric actuator (PA6-Nylon** - 1)* | 7 | Stem O-Ring (EPDM or FKM - 1)* | 15 | Primary gasket (EPDM or FKM - 1)* |
| 20 | Pneumatic actuator (Finished aluminium - 1)* | 8 | Seeger ring (STAINLESS steel - 2) | 16 | Washer (Acciaio INOX - 4) |
| 2 | Screw (STAINLESS steel - 4)* | 9 | Bush O-Ring (EPDM or FKM - 2)* | 17 | Screw (STAINLESS steel - 4) |
| 3 | Washer (STAINLESS steel - 4)* | 10 | Bush (Nylon - 1) | 18 | Protection plug (PE - 1) |
| 4 | Protection plug (PE - 4)* | 11 | Body (PVC-U - 1) | 19 | Square reduction (STAINLESS steel - 1) |
| 5 | Stem (Zinc plated steel - 1)* | 12 | Disk O-Ring (EPDM or FKM - 2)* | | |
| 6 | Stem O-Ring (EPDM or FKM - 1)* | 13 | Anti-friction ring (PTFE - 2)* | | |
| | | 14 | Disk (PVC-U - 1)* | | |

* Spare parts

**DN125÷200: PA6-Nylon + aluminium

The material the component is made of and the quantity supplied are shown in brackets

DISASSEMBLY

- 1) Isolate the valve from the line (release the pressure and empty the pipeline).
- 2) Disconnect the actuator from the compressed air supply and/or power mains.
- 3) Remove the protection plug (4) and screws (2) with the washers (3).
- 4) Remove the actuator (1/20).
- 5) Remove the protection plug (18) and screw (17) with the washer (16).
- 6) Extract the stem (5) and disk (14).
- 7) Remove the anti-friction rings (13) and seals (12).
- 8) Remove the seal (15) from the body (11).
- 9) Remove the Seeger ring (8) and guide bush (10).
- 10) Remove seals (6) and (7).

ASSEMBLY

- 1) Place the liner (15) on the body (11).
- 2) Insert seals (6 and 7) on the stem (5).
- 3) Insert the gaskets (9) on the guide bush (10) and the bush on the stem (4). Lock the bush using the Seeger ring (8).
- 4) Position the seals (12) and then the anti-friction rings (13) on the disk (14) and the disk inside the body, after having lubricated the seal (15).
- 5) Insert the through stem (5) in the body (11) and disk (14).
- 6) Tighten screw (17) with washer (16) and insert the protection plug (18).
- 7) Position the handle (1/20) on the stem.
- 8) Tighten screws (2) with washers (3) and insert the protection plugs (4).
- 9) Reconnect the actuator to the pneumatic and/or power supplies.



All operations on equipment under pressure or containing compressed springs must be carried out under safe conditions for the operator.

Note: during mounting operations, it is advisable to lubricate the rubber seals. Mineral oils are not recommended for this task as they react aggressively with EPDM rubber.

INSTALLATION

JOINTS

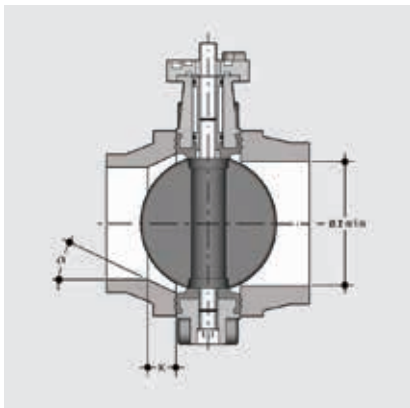

Before proceeding with the installation of the stubs, check that the bore of the fittings has sufficient clearance to allow the valve disk to open correctly. Also check the maximum coupling distance for the liner. Before proceeding with the installation of the FE valve, check that the bore of the stubs allows the correct opening of the disk.

DN	l min.
40	25
50	28
65	47
80	64
100	84
125	108
150	134
200	187

To install on PVC-U collars, check the valve-collar-flange couplings in the following table.

d	DN	50	63	75	90	110	125	140	160	200	225
		40	50	65	80	100	100	125	150	200	200
50	40	■									
63	50		■								
75	65			■							
90	80				■						
110	100					■					
140	125						■				
160	150							■			
225	200									■	**

Stub with female end for solvent welding according to EN ISO 1452 and DIN 8063-4

* With special stub d125 DN125 for FE d140 DN125 and flange d140 DN125

** With special stub d200 DN 200 for FE d225 DN 200 and flange d225 DN 200

For the installation of PP-PE stubs, for butt welding a short spigot or electrofusion/ butt welding a long spigot, check the valve-stub-flange couplings and the K - a chamfer dimensions where necessary according to the different SDRs in the following table.

	d	50	63	75	90	110	125	140	160	180	200	225	250	280	315
	DN	40	50	65	80	100	100	125	150	150	200	200	250	250	300
FE	50														
	63														
	75														
	90														
	110														
	140														
	160														
	225														
SDR	17/17,6										k=26,5 a=20°		k=15,7 a=25°		k=13,3 a=25°
	11								k=35 a=20°		k=35 a=25°	k=40 a=15°	k=32,5 a=25°	k=35 a=25°	k=34,5 a=25°
	7,4				k=10 a=35°	k=15 a=35°		k=20 a=30°	k=35 a=20°	k=15 a=35°	k=40 a=20°	k=35 a=30°	k=55 a=30°	k=35 a=30°	k=65 a=30°

Short/long spigot stubs according to EN ISO 15494 and DIN 16962/16963 and flange

POSITIONING THE VALVE

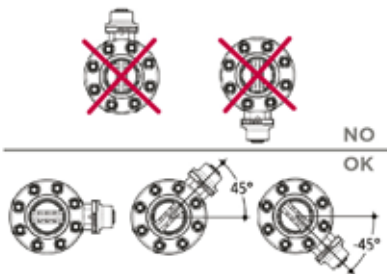

1) Position the valve between two flanged stubs, taking care to respect the installation tolerances Z. It is advisable to always install the valve with the disk partially closed (it must not exit the body) and avoid any misalignment of the flanges, as this may cause leaks.

2) The valve is two-way and can be installed in any position. It can also be installed at end line or tank.

3) Where possible comply with the following requirements:

- Conveying dirty fluids: position the valve with the stem inclined at an angle of 45° to the pipe support plane.
- Conveying fluids with sediment: position the valve with the stem parallel to the pipe support plane.
- Conveying clean fluids: position the valve with the stem perpendicular to the pipe support plane.

TIGHTENING THE STUD-BOLTS

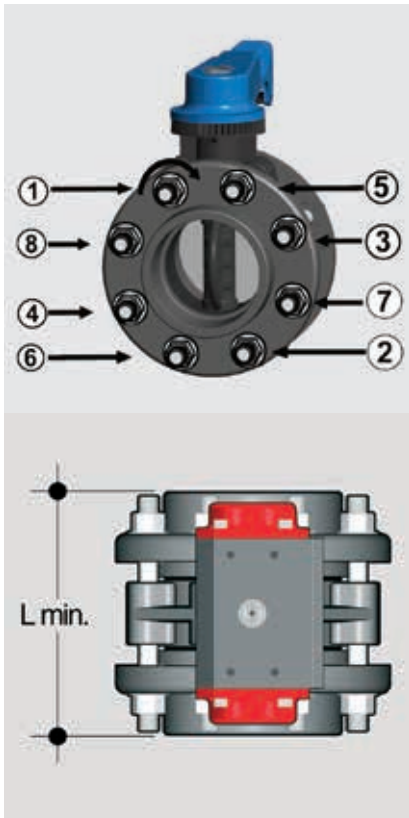

Before tightening the stud-bolts, it is advisable to open the disk in order to prevent damage to the seal. Tighten the stud-bolts in a uniform manner, in the order indicated in the figure, to the nominal operating torque value indicated in the table. The stud-bolts do not need to be excessively tightened in order to produce a perfect hydraulic seal.

DN	L min.	*Nm
40	M16 x150	9
50	M16 x150	12
65	M16 x170	15
80	M16 x180	18
100	M16 x180	20
125	M16 x210	35
150	M20 x 240	40
200	M20 x 260	55

* Tightening torques for nuts and bolts on couplings with backing rings.

Values required to obtain the hydraulic test seal (1.5xPN at 20°C) (new or lubricated nuts and bolts)

JIS FLANGED OPTIONS

FE is suited for wafer flanged installation in JIS K10 standard in DN40 (1"1/2) - DN150 (6") range and in JIS K5 in DN40 (1"1/2) - DN200 (8") range.

WARNINGS

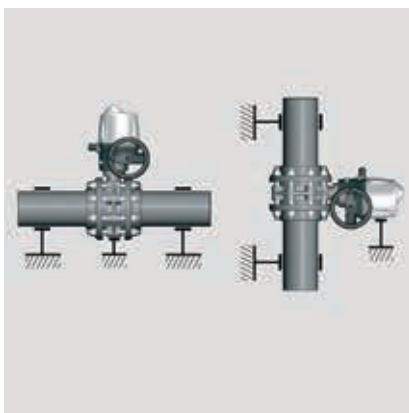

Make sure that the valves installed on the system are suitably supported for their weight.

Always avoid sudden manoeuvres and protect the valve from accidental operations. To this end, it is advisable to install a reduction gear, available on request.



FK/CE - FK/CP DN 40÷400

PVC-U/PVC-C/PP-H/PVDF

ELECTRICALLY OR PNEUMATICALLY ACTUATED
BUTTERFLY VALVE



FK/CE – FK/CP

DN 40÷400

The FK is a butterfly valve for shutting off and regulating flow, with structural characteristics that make it ideal for industrial applications requiring high performance and long-term reliability.

ELECTRICALLY OR PNEUMATICALLY ACTUATED BUTTERFLY VALVE

- PVC-U, PVCC, PP-H, ABS and PVDF through shaft disk
- Overall dimensions of the valve in accordance with standard ISO 5752 (DN 40÷200 Medium Series 25, DN 250÷ 300 Long Series 16) and DIN 3202 K2 and ISO 5752 (DN 65÷200 K2, DN 250÷300 K3)
- Can also be installed as an end line valve, bottom discharge valve or tank dump valve
- Special Lug version PN 10 fully drilled to DIN 2501 or ANSI B16.5 cl.150 with **molded-in AISI 316 stainless steel threaded inserts**
- **Valve material compatibility** with water conveyance, drinking water and other food substances according to **current regulations**
- Possibility of installing pneumatic and/or electric actuators by applying ISO standard drilling PP-GR flanges. DN 40 ÷ 200 valve fitted with plate with rack in PP-GR. For actuated versions with flange drilled according to ISO 5211 F05, F07, F10. DN 250÷400 valve, fitted with one-piece top flange in high mechanical strength PP-GR with mounting flange for internal components drilled according to standard ISO 5211 F10 (excluding DN 350÷400), F12, F14.

Technical specifications - FK	
Size range	DN 40 ÷ 400
PVC-U nominal pressure	Wafer version DN 40 ÷ 50: PN16 with water at 20° C DN 65÷250: PN 10 with water at 20° C DN 300: PN 8 with water at 20° C DN 350: PN 7 with water at 20° C DN 400: PN 6 with water at 20° C Lug version DN 65÷200: PN 10 with water at 20° C DN 250÷300: PN 6 with water at 20° C
PVC-C nominal pressure	Wafer version DN 40 ÷ 50: PN16 with water at 20° C DN 65÷250: PN 10 with water at 20° C DN 300: PN 8 with water at 20° C Lug version DN 65÷200: PN 10 with water at 20° C DN 250÷300: PN 6 with water at 20° C
PP-H nominal pressure	Wafer version DN 40 ÷ 250: PN 10 with water at 20° C DN 300: PN 8 with water at 20° C DN 350: PN 7 with water at 20° C DN 400: PN 6 with water at 20° C Lug version DN 65÷200: PN 10 with water at 20° C DN 250÷300: PN 6 with water at 20° C
PVDF nominal pressure	Wafer version DN 40 ÷ 50: PN16 with water at 20° C DN 65÷250: PN 10 with water at 20° C DN 300: PN 8 with water at 20° C DN 350: PN 7 with water at 20° C DN 400: PN 6 with water at 20° C Lug version DN 65÷200: PN 10 with water at 20° C DN 250÷300: PN 6 with water at 20° C
Temperature range	PVC-U: 0 °C ÷ 60 °C PVC-C: 0° C ÷ 100° C PP-H: 0° C ÷ 100° C PVDF: -40° C ÷ 140° C
PVC-U coupling standards	Flanging system: EN ISO 1452, EN ISO 15493, DIN 2501, ISO 7005-1, EN 1092-1, ANSI B16.5 Cl.150, JIS B2220
PVC-C coupling standards	Flanging system: EN ISO 15493, DIN 2501, ISO 7005-1, EN 1092-1, ANSI B16.5 Cl.150, JIS B2220
PP-H coupling standards	Flanging system: EN ISO 15494, DIN 2501, ISO 7005-1, EN 1092-1, ANSI B16.5 Cl.150, JIS B2220
PVDF coupling standards	Flanging system: EN ISO 10931, DIN 2501, ISO 7005-1, EN 1092-1, ANSI B16.5 Cl.150, JIS B2220
Reference standards	PVC-U construction criteria: EN ISO 16136, EN ISO 1452, EN ISO 15493 PVC-C construction criteria: EN ISO 16136, EN ISO 15493 PP-H construction criteria: EN ISO 16136, EN ISO 15494 PVDF construction criteria: EN ISO 16136, EN ISO 10931 Test methods and requirements: ISO 9393 Actuator couplings: ISO 5211
Valve material	Body: PP-GR Disk: PVC-U, PVC-C, PP-H, PVDF, ABS Stem: STAINLESS steel AISI 316
Seal material	Liner: EPDM , FKM. On request NBR
Control options	Electric actuator; pneumatic actuator

In addition to the manually actuated version, FK is also available in FK/CE electrically actuated and FK/CP pneumatically actuated configurations. FK/CE and FK/CP are constructed with actuators meeting current regulations and selected by FIP according to their quality and reliability requirements. The efficiency of these valves, tested according to the company's quality standards, is guaranteed by the expertise and know-how that FIP dedicates to manufacturing its products..

Technical specifications - Electric actuator	
Reference standards	Construction criteria: Electromagnetic compatibility EMC 2004/108/CE. Low voltage directive 2006/95/CE. Machinery directive 2006/42/CE. R.O.H.S. directive 2011/65/CE Coupling for valves: ISO 5211; DIN 3337
Actuator material	Plastic parts: PA6,6 FV 30% and Nylon. Metallic parts: 304L stainless steel or steel + zinc plating (DN40-100); Aluminium + EPOXY paint (DN125-400)
Supply Voltage	12V DC* - 24V AC/DC - 90-240V AC - 400V three phase* *voltages available upon request
Temperature range	From -10 °C to +55 °C(DN40-300) From -20 °C to +70 °C(DN350-400)
Standard equipment	<ul style="list-style-type: none"> • Manual safety override • Visual position indicator • Two auxiliary limit switches (5A) adjustable FC1, FC2 • Torque limiter • Anti-condensation heating element (DN125-400)
Accessories	<ul style="list-style-type: none"> • Positioner board 4-20 mA or 0-10V DC • Fail Safe unit • Anti-condensation heating element • Feedback potentiometer 100 - 1000 - 5000 - 10000 Ohm • 4-20 mA position transmitter • Kit with additional pair of auxiliary limit switches
Special versions upon request	Different operating times CEI34 50% service Protection class IP68 or ATEX II 2 GD EEx d IIB T6
Electrical connection	<ul style="list-style-type: none"> • Power supply: connector DIN 43650 3P + GND (DN 40-100); cable gland ISO M20 (DN 125-400) • Limit switch: Cable gland ISO M20

Technical specifications - Pneumatic actuator	
Reference standards	Construction criteria: Machinery directive 2006/42/CE R.O.H.S. directive 2011/65/CE EN 15714-3 Coupling for valves: ISO 5211, DIN 3337 Compressed air connections: NAMUR VDI/VDE-3845 Top connections for accessories: NAMUR VDI/VDE-3845
Actuator material	Body: hard coat anodised extruded aluminium. IP67 Bonnet: polyester powder painted aluminium alloy Pinion: nickel-plated carbon steel Other materials available upon request
Control air pressure	From 5 to 8 bar. Pmax= 10 bar Reduced control pressure executions available upon request
Power supply	Dry or lubricated filtered compressed air. If using other fluids, contact the FIP service centre
Temperature range	From -20 °C to +80 °C
Accessories	<ul style="list-style-type: none"> • Optical position indicator • LSQT electromechanical and PNP inductive limit switch boxes (Namur upon request) • Electric-pneumatic positioner 4-20 mA • 3-5/2 way pilot solenoid valves
Available options	Body and bonnet with PTFE, AISI 316 or AISI 316 coating with mirror polishing. 304 or 316 stainless steel pinion.

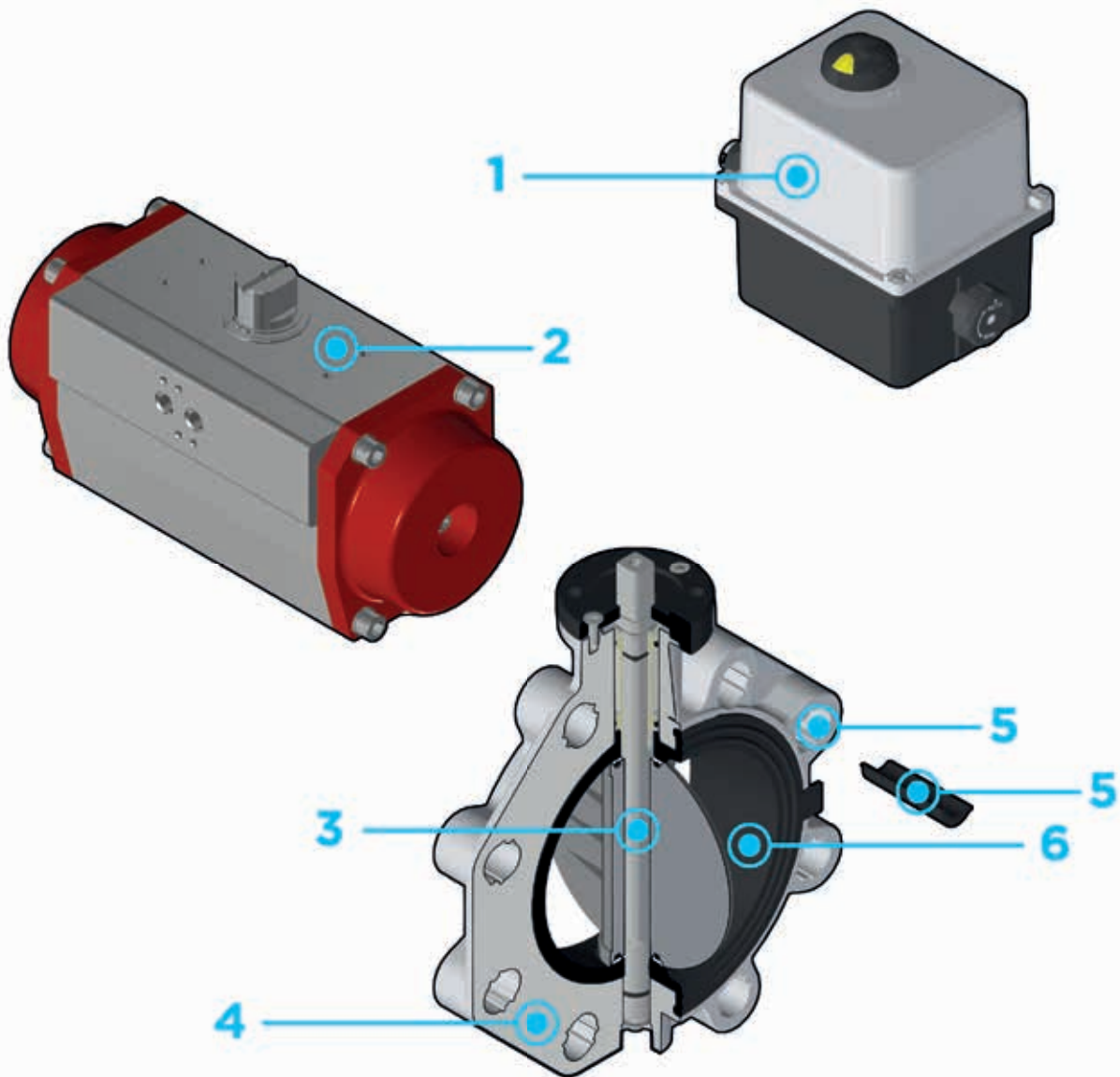

1 Electric actuator constructed according to FIP specifications; with plastic shell and standard emergency override. Available with voltages from 12 to 240V.

2 Rack & pinion type pneumatic actuator constructed according to FIP specifications: fully protected against weather corrosion available in double-acting (DA) or simple-acting normally closed (NC) or normally open (NO) versions.

3 Square section **stainless steel square section stem** completely isolated from the fluid.

4 **Body in fibreglass reinforced polypropylene** based compound (PP-GR) **UV resistant** and characterised by **high mechanical resistance**.

5 **Drilling pattern with oval slots** that allow coupling to flanges according to numerous.

international standards. The special **self-centring inserts in ABS supplied for DN 40÷200** guarantee the **correct axial** alignment of the valve during installation. For DN 250÷400 valves, the drilling pattern for the self-centring system is of the traditional type according to DIN and ANSI standards.

6 **Interchangeable liner** with the dual function of forming a hydraulic seal and isolating the body from the fluid.

TECHNICAL DATA

PRESSURE VARIATION ACCORDING TO TEMPERATURE

PVC-U BODY

For water and non-hazardous fluids with regard to which the material is classified as CHEMICALLY RESISTANT. In other cases, a reduction of the nominal pressure PN is required (25 years with safety factor).

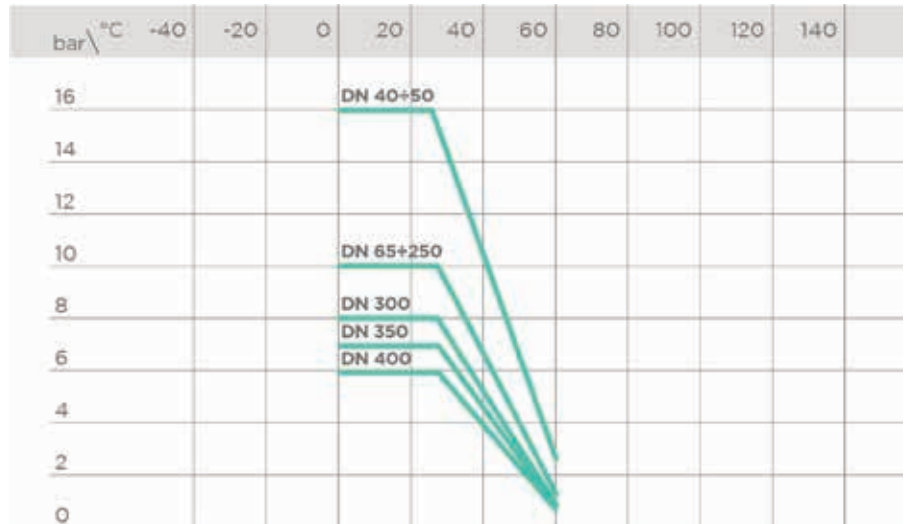

PVC-C BODY

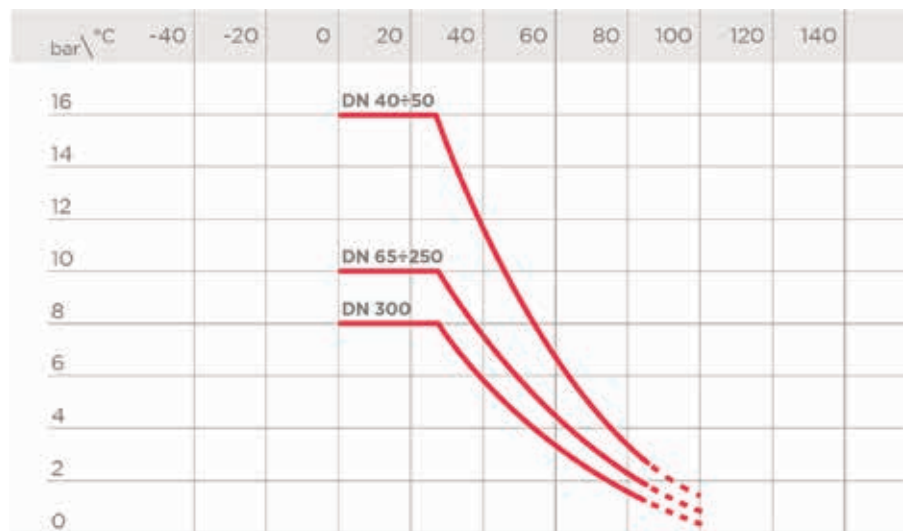

PP-H BODY

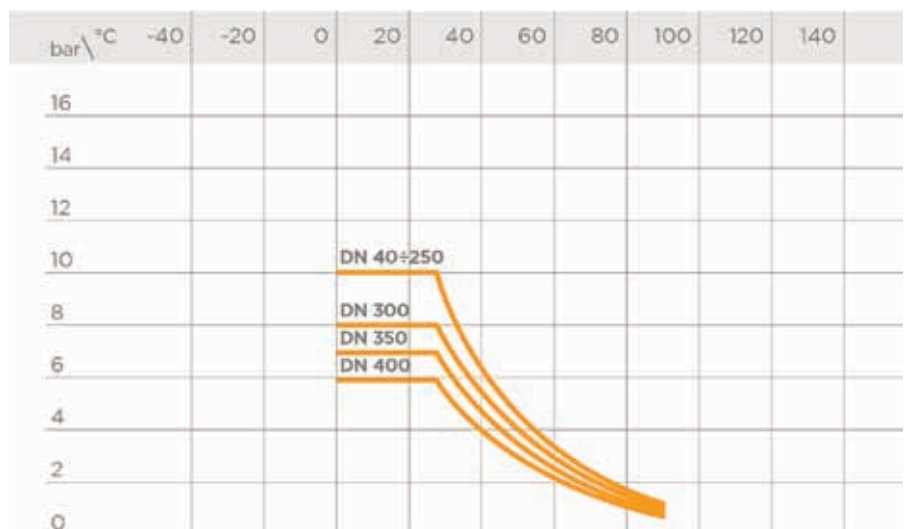

PVDF BODY

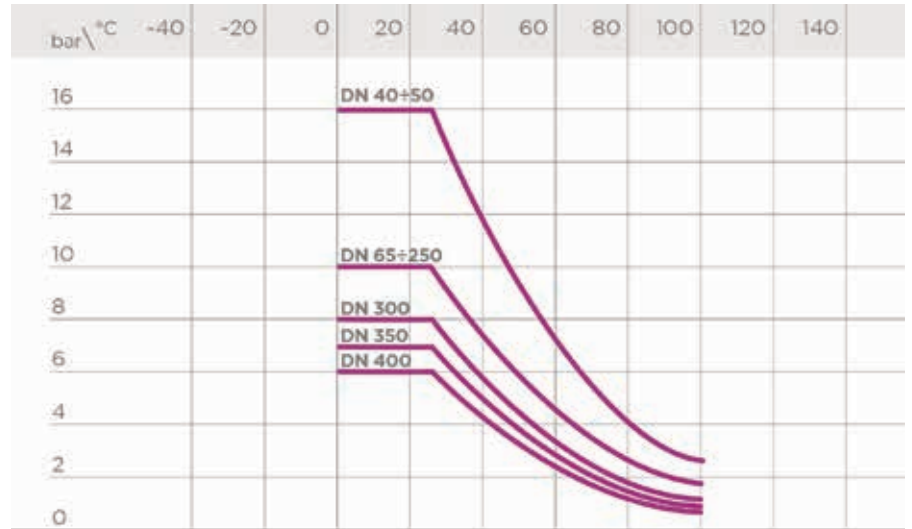

PRESSURE DROP GRAPH

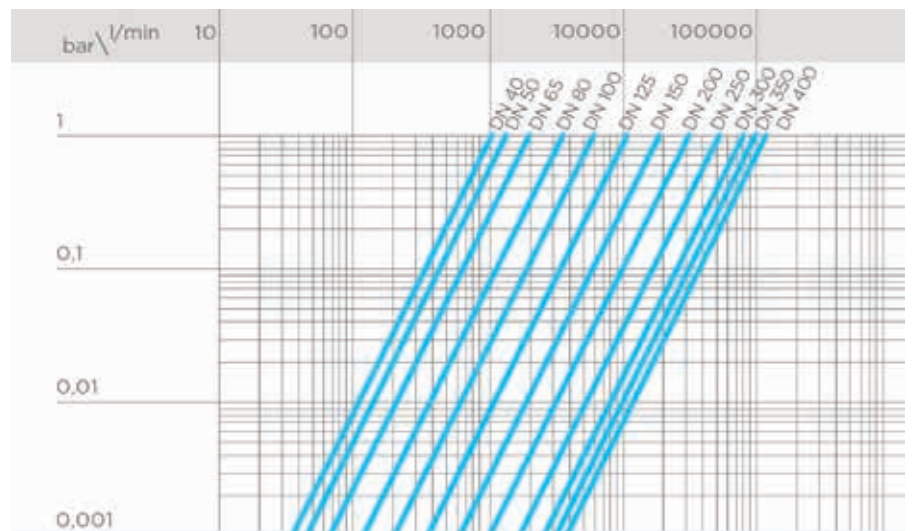

K_v100 FLOW COEFFICIENT DN 40-150

The K_v100 flow coefficient is the Q flow of litres per minute of water at a temperature of 20°C that will generate Δp= 1 bar pressure drop at a certain valve position.
The K_v100 values shown in the table are calculated with the valve completely open.

DN	40	50	65	80	100	125	150
Kv100 l/min	1000	1285	1700	3550	5900	9850	18700

K_v100 FLOW COEFFICIENT DN 200-400

The K_v100 flow coefficient is the Q flow of litres per minute of water at a temperature of 20°C that will generate Δp= 1 bar pressure drop at a certain valve position.

The K_v100 values shown in the table are calculated with the valve completely open.

DN	200	250	300	350	400
Kv100 l/min	30500	53200	81600	94100	124900

RELATIVE FLOW COEFFICIENT GRAPH

The relative flow coefficient is the flow rate through the valve as a function of the degree of valve opening.

X axis: Percentage opening of the disk

Y axis: Relative flow coefficient

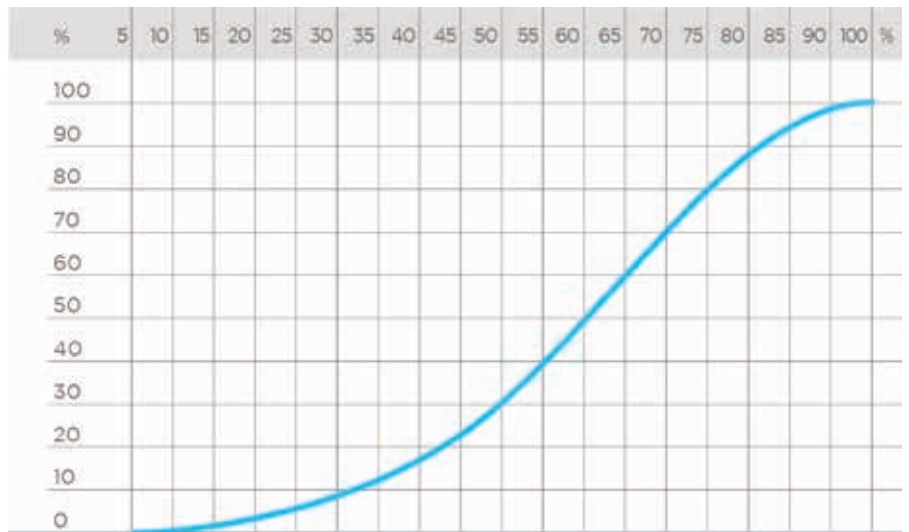

ELECTRIC ACTUATOR DATA

DN40÷65 FUNCTIONAL CHARACTERISTICS

Characteristics	DC	AC/DC	AC
Power supply	*12V	24V	90÷240V
Power	15W	15W	15W
Max operating time	11 s	12 s	13 s
IEC34 service	50%	30%	30%
Protection class	IP66	IP65	IP65
Frequency	-	50/60 Hz	50/60 Hz

DN80÷100

Characteristics	DC	AC/DC	AC
Power supply	*12V	24V	90÷240V
Power	45W	45W	45W
Max operating time	12 s	13 s	15 s
IEC34 service	50%	30%	30%
Protection class	IP66	IP65	IP65
Frequency	-	50/60 Hz	50/60 Hz

DN125÷150

Characteristics	AC/DC	AC
Power supply	24V	90÷240V
Power	85W	85W
Max operating time	30 s	30 s
IEC34 service	50%	50%
Protection class	IP67	IP67
Frequency	50/60 Hz	50/60 Hz

DN200

Characteristics	AC/DC	AC
Power supply	24V	90÷240V
Power	85W	85W
Max operating time	50 s	50 s
IEC34 service	50%	50%
Protection class	IP67	IP67
Frequency	50/60 Hz	50/60 Hz

DN250-400

Characteristics	AC/DC	AC
Power supply	24V*	230
Power	-	250W
Max operating time	-	38 s
IEC34 service	-	50%
Protection class	IP67	IP67
Frequency	50/60 Hz	50/60 Hz

*Upon request

DN 40-100 WIRING DIAGRAM

- A 3-point connection
- B ON/OFF connection

POWER CONNECTION DIAGRAM

- 1 Shared
- 2 Open
- 3 Closed

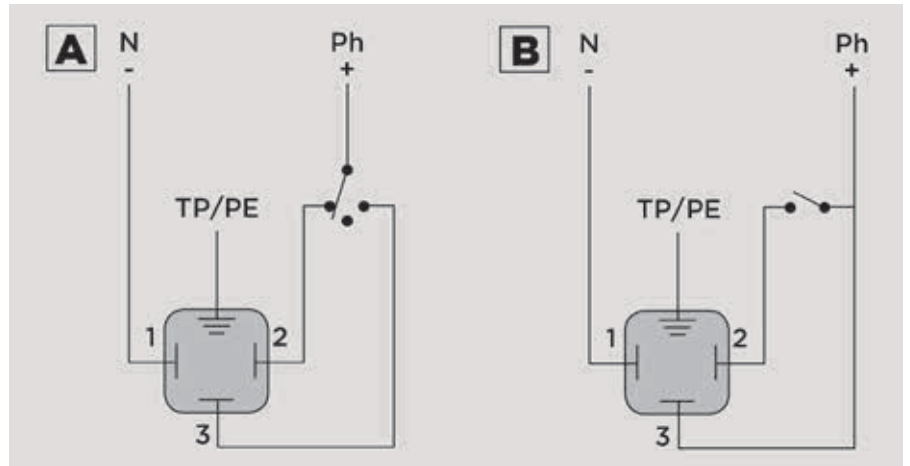

AUXILIARY LIMIT SWITCH CONNECTION DIAGRAM

- FC1 Open auxiliary limit switch
- FC2 Close auxiliary limit switch

- 4 Shared FC1
- 5 Open FC1
- 6 Shared FC2
- 7 Open FC2
- 8 Close FC1
- 9 Close FC2

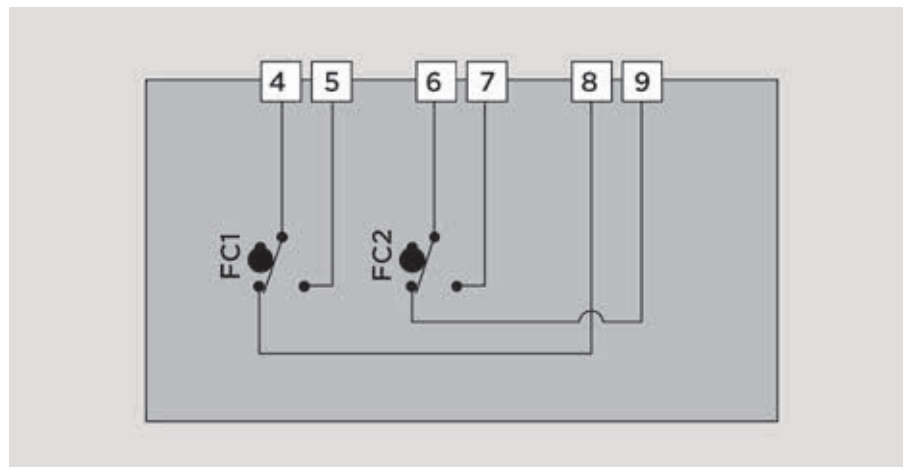

125-200 WIRING DIAGRAM

- A 3-point connection
- B ON/OFF connection

POWER CONNECTION DIAGRAM

- 1 Shared
- 2 Open
- 3 Closed

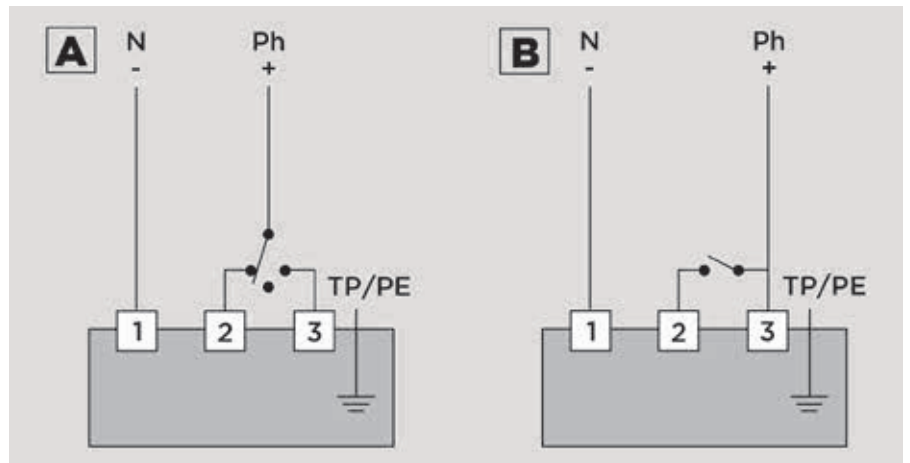

AUXILIARY LIMIT SWITCH CONNECTION DIAGRAM

FC1 Open auxiliary limit switch
FC2 Close auxiliary limit switch

- 4 Shared FC1
- 5 Open FC1
- 6 Shared FC2
- 7 Open FC2
- 8 Close FC1
- 9 Close FC2

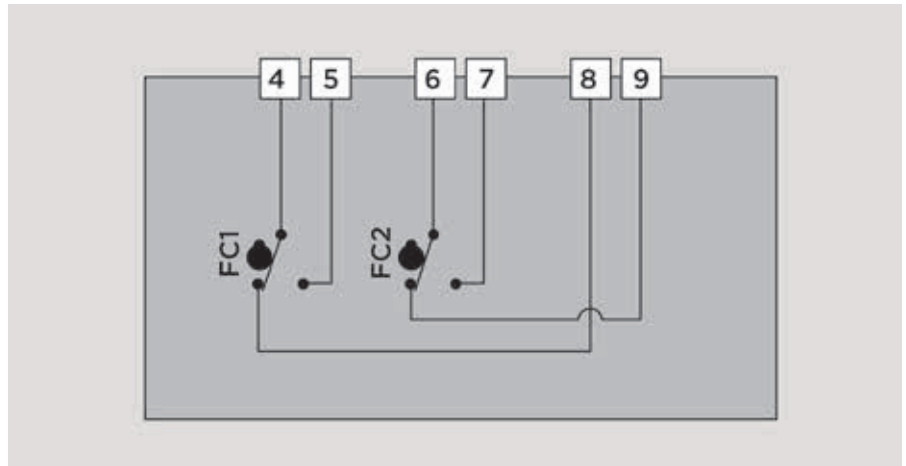

DN 250-400 (230V AC) WIRING DIAGRAM

POWER CONNECTION DIAGRAM

- 1 Shared
- 2 Open
- 3 Closed

AUXILIARY LIMIT SWITCH CONNECTION DIAGRAM

FC1 Open auxiliary limit switch
FC2 Close auxiliary limit switch

- 4 Shared FC1
- 5 Open FC1
- 6 Shared FC2
- 7 Open FC2
- 8 Close FC1
- 9 Close FC2

HEATING ELEMENT

- 10 N 230V AC
- 11 Ph 230V AC

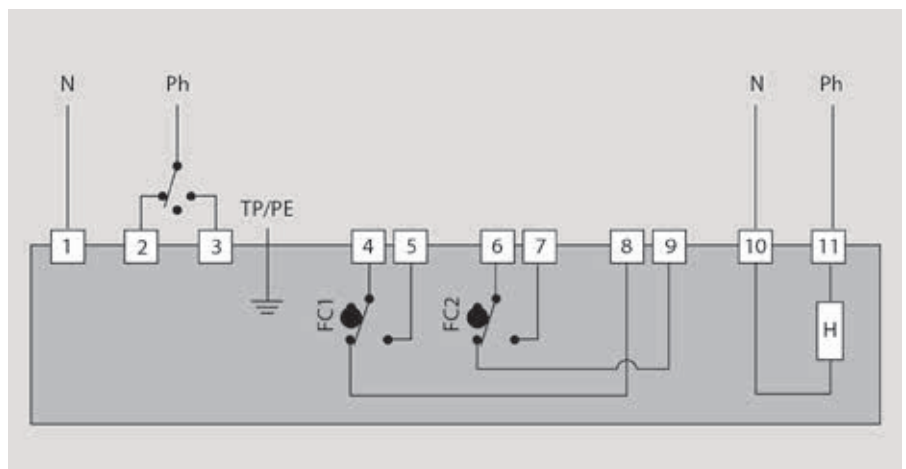

250-400 (24V AC/24V DC) WIRING DIAGRAM

A 3-point connection
B ON/OFF connection

POWER CONNECTION DIAGRAM

- 1 Shared
- 2 Open
- 3 Closed

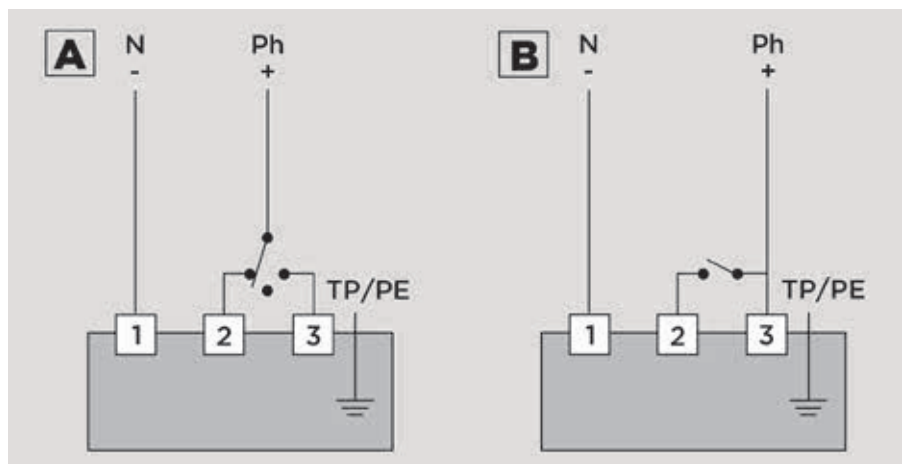

AUXILIARY LIMIT SWITCH CONNECTION DIAGRAM

FC1 Open auxiliary limit switch
FC2 Close auxiliary limit switch

- 14** Shared FC1
- 13** Open FC1
- 17** Shared FC2
- 16** Open FC2
- 15** Close FC1
- 18** Close FC2

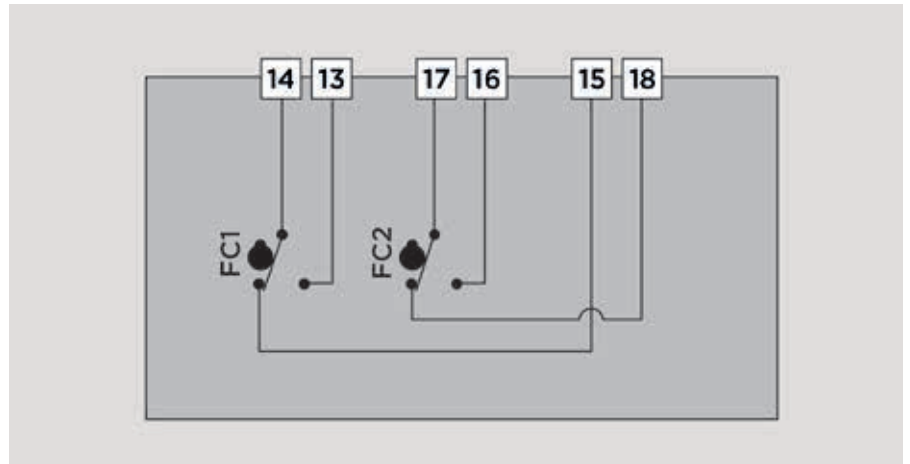

PNEUMATIC ACTUATOR DATA

FUNCTIONAL CHARACTERISTICS

Function type	double-acting	Normally closed (NC)	Normally Open (NO)
Valve opening	air	air	spring
Valve closing	air	spring	air

ACTUATOR CAPACITY DN40-200

DN	40	50	65	80	100	125	150	200
DA	0.45 L	0.45 L	0.45 L	0.61 L	0.98 L	0.98 L	1.8 L	2.8 L
SA (NC-NO)	0.18 L	0.244 L	0.244 L	0.302 L	0.72 L	1.12 L	1.12 L	3.2 L

L: litre, equivalent to 10^{-3} m^3

Air consumption in normal litres (or normal cubic metres) per operating cycle can be calculated by correcting according to operating conditions such as control air pressure.

ACTUATOR CAPACITY DN 250-400

DN	250	300	350	400
DA	15.5 L	15.5 L	11.1 L	11.1 L
SA (NC-NO)	5.68 L	5.68 L	7.68 L	7.68 L

L: litre, equivalent to 10^{-3} m^3

Air consumption in normal litres (or normal cubic metres) per operating cycle can be calculated by correcting according to operating conditions such as control air pressure.

COMPRESSED AIR CONNECTIONS

Function type	Double-acting (DA)	Normally closed (NC)	Normally Open (NO)
Valve opening	Inlet A	Inlet A	-
Valve closing	Inlet B	-	Inlet A

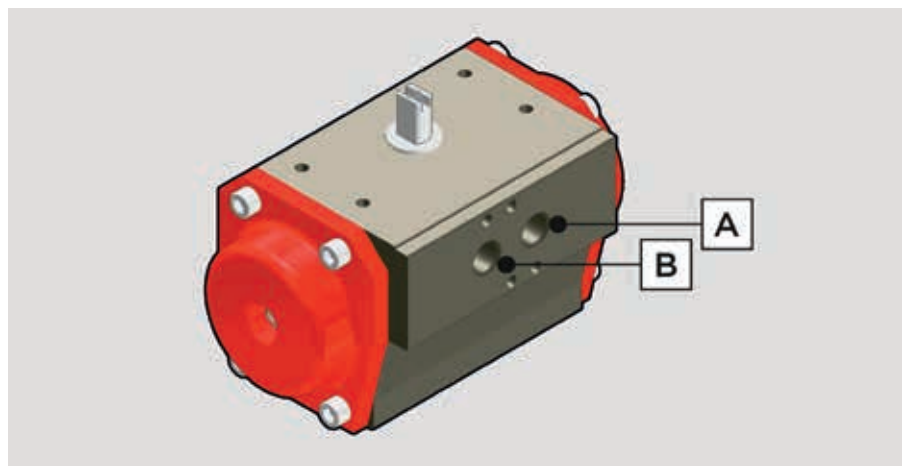

DIMENSIONS

FK/CE DN 40÷400 PVC-U

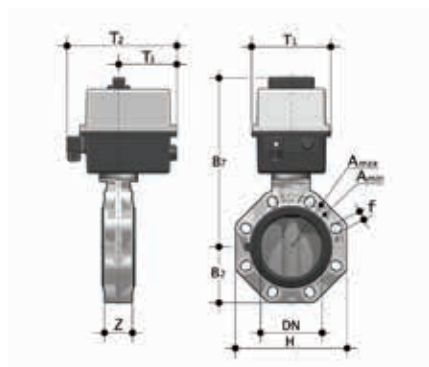

FKOV/CE 90-240V AC DN 40-100

Butterfly valve with multi-volt electric actuator 90-240 V AC 50-60 Hz

d	DN	PN	B ₂	H	Z	A _{min}	A _{max}	f	U	B ₁	T ₁	T ₂	T ₃	g	EPDM Code	FKM Code
50-1 1/2"	40	16	60	132	33	99	109	19	4	253	92	189	91	2074	FKOVEM050E	FKOVEM050F
63-2"	50	16	70	147	43	115	125.5	19	4	259	92	189	91	2254	FKOVEM063E	FKOVEM063F
75-2 1/2"	65	10	80	165	46	128	144	19	4	266	92	189	91	2500	FKOVEM075E	FKOVEM075F
90-3"	80	10	93	185	49	145	160	19	12	308	128	204	95.5	4200	FKOVEM090E	FKOVEM090F
110-4"	100	10	107	211	56	165	190	19	8	322	128	204	95.5	4550	FKOVEM110E	FKOVEM110F

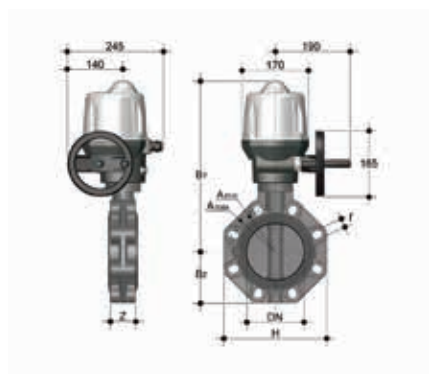

FKOV/CE 90-240V AC DN 125-200

Butterfly valve with multi-volt electric actuator 90-240 V AC 50-60 Hz

d	DN	PN	B ₂	H	Z	A _{min}	A _{max}	f	U	B ₁	g	EPDM Code	FKM Code
*125/140-5"	125	10	120	240	64	204	215	23	8	425	8150	FKOVEM140E	FKOVEM140F
160-6"	150	10	134	268	70	230	242	23	8	438	8900	FKOVEM160E	FKOVEM160F
**200/225-8"	200	10	161	323	71	280	298	23	8	485	11600	FKOVEM225E	FKOVEM225F

* FKOV d140 with special adapter collars d125
 ** FKOV d225 with special adapter collars d200

DIMENSIONS

FK/CE DN 40÷400 PVC-U

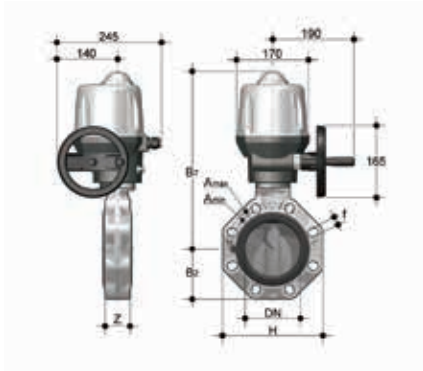

FKOV/CE 90-240V AC DN 250-300

Butterfly valve with multi-volt electric actuator 90-240 V AC 50-60 Hz

d	DN	PN	B ₂	H	Z	ΦA	f	U	B ₁	g	EPDM Code	FKM Code
250/280	***250	10	210	405	114	350	22	12	555	32000	FKOVEA280E	FKOVEA280F
315	***300	8	245	475	114	400	22	12	611	39000	FKOVEA315E	FKOVEA315F
10"	****250	10	210	405	114	362	25.4	12	555	32000	FKOAVEA810E	FKOAVEA810F
12"	****300	8	245	475	114	432	25.4	12	611	39000	FKOAVEA812E	FKOAVEA812F

*** ISO-DIN
****ANSI B.16.5 150

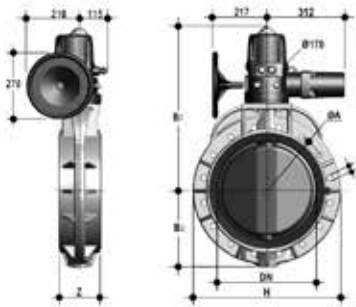

FKOV/CE 90-240V AC DN 350-400

Butterfly valve with multi-volt electric actuator 90-240 V AC 50-60 Hz

d	DN	PN	B ₂	H	Z	ΦA	f	U	B ₁	g	EPDM Code	FKM Code
355	***350	7	280	530	129	460	22	16	636	47000	FKOVEA355E	FKOVEA355F
400	***400	6	306	594	169	515	26	16	656	55000	FKOVEA400E	FKOVEA400F
14"	****350	7	280	530	129	476	28.5	12	636	47000	FKOAVEA814E	FKOAVEA814F
16"	****400	6	306	594	169	540	28.5	16	656	55000	FKOAVEA816E	FKOAVEA816F

***ISO-DIN
****ANSI B.16.5 150

DIMENSIONS

FK/CE DN 40÷400 PVC-U

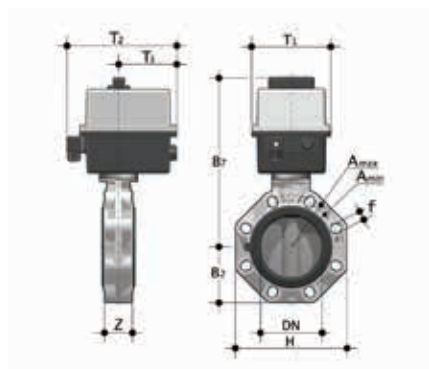

FKOV/CE 24V AC/DC DN 40-100

Butterfly valve with electric actuator 24 V AC/DC

d	DN	PN	B ₂	H	Z	A _{min}	A _{max}	f	U	B ₁	T ₁	T ₂	T ₃	g	EPDM Code	FKM Code
50-1 1/2"	40	16	60	132	33	99	109	19	4	253	92	189	91	2074	FKOVEL050E	FKOVEL050F
63-2"	50	16	70	147	43	115	125.5	19	4	259	92	189	91	2254	FKOVEL063E	FKOVEL063F
75-2 1/2"	65	10	80	165	46	128	144	19	4	266	92	189	91	2500	FKOVEL075E	FKOVEL075F
90-3"	80	10	93	185	49	145	160	19	12	308	128	204	95.5	4200	FKOVEL090E	FKOVEL090F
110-4"	100	10	107	211	56	165	190	19	8	322	128	204	95.5	4550	FKOVEL110E	FKOVEL110F

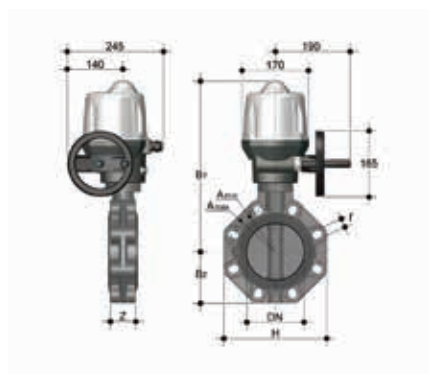

FKOV/CE 24V AC/DC DN 125-200

Butterfly valve with electric actuator 24 V AC/DC

d	DN	PN	B ₂	H	Z	A _{min}	A _{max}	f	U	B ₁	g	EPDM Code	FKM Code
*125/140-5"	125	10	120	240	64	204	215	23	8	425	8150	FKOVEL140E	FKOVEL140F
160-6"	150	10	134	268	70	230	242	23	8	438	8900	FKOVEL160E	FKOVEL160F
**200/225-8"	200	10	161	323	71	280	298	23	8	485	11600	FKOVEL225E	FKOVEL225F

* FKOV d140 with special adapter collars d125
 ** FKOV d225 with special adapter collars d200

DIMENSIONS

FK/CE DN 40÷400 PVC-U

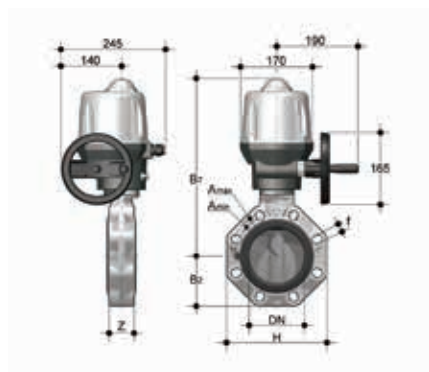

FKOV/CE 24V AC/DC DN 250-300

Butterfly valve with electric actuator 24 V AC/DC

d	DN	PN	B ₂	H	Z	ΦA	f	U	B ₁	g	EPDM Code	FKM Code
250/280	***250	10	210	405	114	350	22	12	555	32000	FKOVEE280E	FKOVEE280F
315	***300	8	245	475	114	400	22	12	611	39000	FKOVEE315E	FKOVEE315F
10"	****250	10	210	405	114	362	25.4	12	555	32000	FKOAVEE810E	FKOAVEE810F
12"	****300	8	245	475	114	432	25.4	12	611	39000	FKOAVEE812E	FKOAVEE812F

***ISO-DIN
****ANSI B.16.5 150

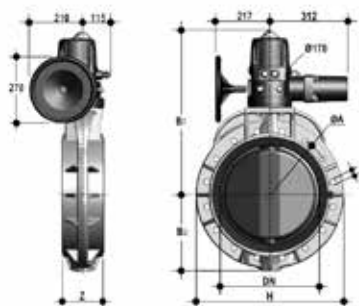

FKOV/CE 24V AC/DC DN 350-400

Butterfly valve with electric actuator 24 V AC/DC

d	DN	PN	B ₂	H	Z	ΦA	f	U	B ₁	g	EPDM Code	FKM Code
355	***350	7	280	530	129	460	22	16	636	47000	FKOVEE355E	FKOVEE355F
400	***400	6	306	594	169	515	26	16	656	55000	FKOVEE400E	FKOVEE400F
14"	****350	7	280	530	129	476	28.5	12	636	47000	FKOAVEE814E	FKOAVEE814F
16"	****400	6	306	594	169	540	28.5	16	656	55000	FKOAVEE816E	FKOAVEE816F

***ISO-DIN
****ANSI B.16.5 150

DIMENSIONS

FK/CE DN 40÷400 PVC-U

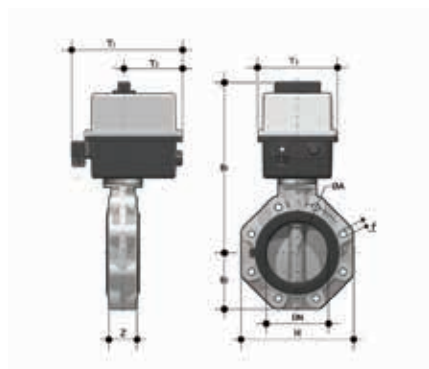

FKOV/CE 90-240V AC LUG ISO DN 65-100

LUG ISO-DIN version butterfly valve with multi-volt electric actuator 90-240 V AC 50-60 Hz

d	DN	PN	B ₂	H	Z	ΦA	f	U	B ₇	T ₁	T ₂	T ₃	g	EPDM Code	FKM Code
75	65	10	80	165	46	145	M16	4	266	92	189	91	2900	FKOLVEM075E	FKOLVEM075F
90	80	10	93	185	49	160	M16	12	308	128	204	95.5	5000	FKOLVEM090E	FKOLVEM090F
110	100	10	107	211	56	180	M16	8	322	128	204	95.5	5350	FKOLVEM110E	FKOLVEM110F

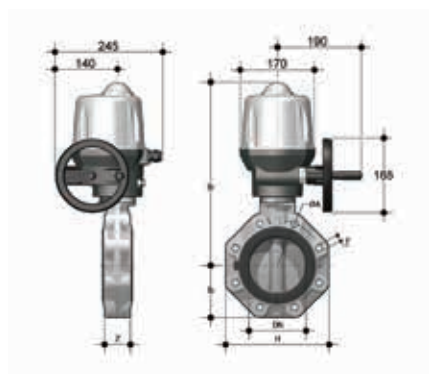

FKOV/CE 90-240V AC LUG ISO DN 125-200

LUG ISO-DIN version butterfly valve with multi-volt electric actuator 90-240 V AC 50-60 Hz

d	DN	PN	B ₂	H	Z	ΦA	f	U	B ₇	g	EPDM Code	FKM Code
*125/140	125	10	120	240	64	210	M16	8	425	9750	FKOLVEM140E	FKOLVEM140F
160	150	10	134	268	70	240	M20	8	438	10500	FKOLVEM160E	FKOLVEM160F
*200/225	200	10	161	323	71	295	M20	8	485	13200	FKOLVEM225E	FKOLVEM225F

* FKOV d140 with special adapter collars d125

** FKOV d225 with special adapter collars d200

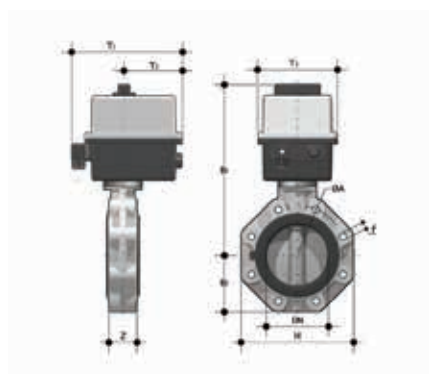

FKOV/CE 24V AC/DC LUG ISO DN 65-100

LUG ISO-DIN version butterfly valve with electric 24 V AC/DC

d	DN	PN	B ₂	H	Z	ΦA	f	U	B ₇	T ₁	T ₂	T ₃	g	EPDM Code	FKM Code
75	65	10	80	165	46	145	M16	4	266	92	189	91	2900	FKOLVEL075E	FKOLVEL075F
90	80	10	93	185	49	160	M16	12	308	128	204	95.5	5000	FKOLVEL090E	FKOLVEL090F
110	100	10	107	211	56	180	M16	8	322	128	204	95.5	5350	FKOLVEL110E	FKOLVEL110F

DIMENSIONS

FK/CE DN 40÷400 PVC-U

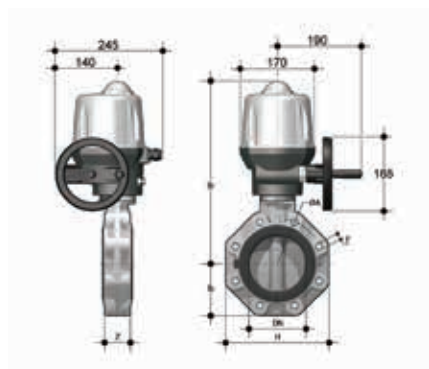

FKOV/CE 24V AC/DC LUG ISO DN 125-200

LUG ISO-DIN version butterfly valve with electric 24 V AC/DC

d	DN	PN	B ₂	H	Z	ΦA	f	U	B ₁	g	EPDM Code	FKM Code
*125/140	125	10	120	240	64	210	M16	8	425	9750	FKOLVEL140E	FKOLVEL140F
160	150	10	134	268	70	240	M20	8	438	10500	FKOLVEL160E	FKOLVEL160F
**200/225	200	10	161	323	71	295	M20	8	485	13200	FKOLVEL225E	FKOLVEL225F

* FKOV d140 with special adapter collars d125

** FKOV d225 with special adapter collars d200

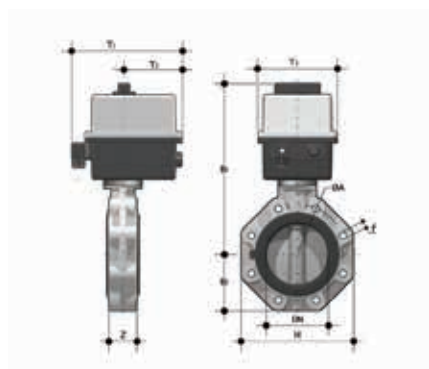

FKOV/CE 90-240V AC LUG ANSI DN 65-100

LUG ANSI version butterfly valve with multi-volt electric actuator 90-240 V AC 50-60 Hz

d	DN	PN	B ₂	H	Z	ΦA	f	U	B ₁	T ₁	T ₂	T ₃	g	EPDM Code	FKM Code
2 1/2"	65	10	80	165	46	139.7	5/8"	4	266	92	189	91	2900	FKOALVEM212E	FKOALVEM212F
3"	80	10	93	185	49	152.4	5/8"	12	308	128	204	95.5	5000	FKOALVEM300E	FKOALVEM300F
4"	100	10	107	211	56	190.5	5/8"	8	322	128	204	95.5	5350	FKOALVEM400E	FKOALVEM400F

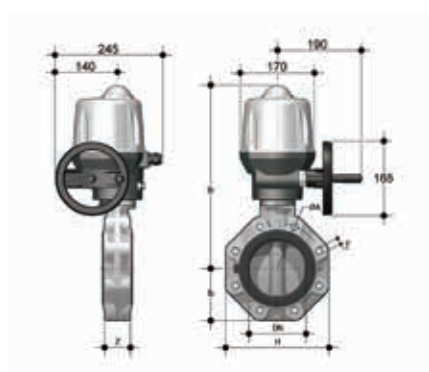

FKOV/CE 90-240V AC LUG ANSI DN 125-200

LUG ANSI version butterfly valve with multi-volt electric actuator 90-240 V AC 50-60 Hz

d	DN	PN	B ₂	H	Z	ΦA	f	U	B ₁	g	EPDM Code	FKM Code
5"	125	10	120	240	64	215.9	3/4"	8	425	9750	FKOALVEM500E	FKOALVEM500F
6"	150	10	134	268	70	241.3	3/4"	8	438	10500	FKOALVEM600E	FKOALVEM600F
8"	200	10	161	323	71	298.4	3/4"	8	485	13200	FKOALVEM800E	FKOALVEM800F

DIMENSIONS

FK/CE DN 40÷400 PVC-U

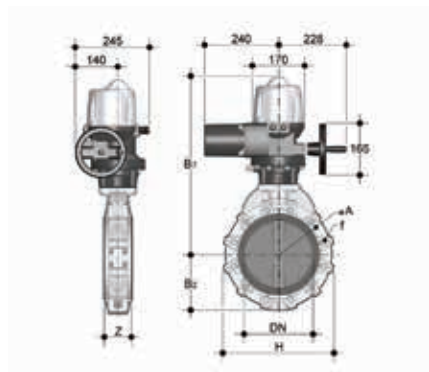

FKOV/CE 90-240V AC LUG ANSI DN 250-300

LUG ANSI version butterfly valve with multi-volt electric actuator 90-240 V AC 50-60 Hz

d	DN	PN	B ₂	H	Z	ΦA	f	U	B ₇	g	EPDM Code	FKM Code
10"	250	6	210	405	114	362	7/8"	12	555	36800	FKOALVEA810E	FKOALVEA810F
12"	300	6	245	475	114	431.8	7/8"	12	611	43800	FKOALVEA812E	FKOALVEA812F

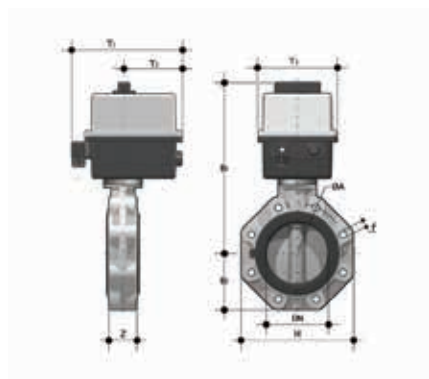

FKOV/CE 24V AC/DC LUG ANSI DN 65-100

LUG ANSI version butterfly valve with electric actuator 24 V AC/DC

d	DN	PN	B ₂	H	Z	ΦA	f	U	B ₇	T ₁	T ₂	T ₃	g	EPDM Code	FKM Code
2 1/2"	65	10	80	165	46	139.7	5/8"	4	266	92	189	91	2900	FKOALVEL212E	FKOALVEL212F
3"	80	10	93	185	49	152.4	5/8"	12	308	128	204	95.5	5000	FKOALVEL300E	FKOALVEL300F
4"	100	10	107	211	56	190.5	5/8"	8	322	128	204	95.5	5350	FKOALVEL400E	FKOALVEL400F

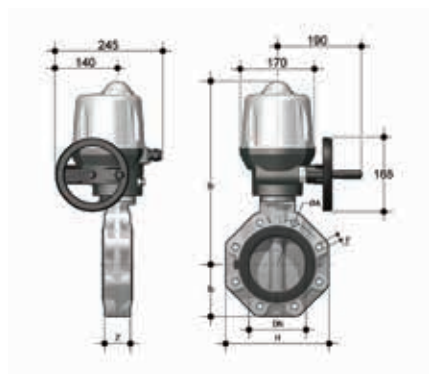

FKOV/CE 24V AC/DC LUG ANSI DN 125-200

LUG ANSI version butterfly valve with electric actuator 24 V AC/DC

d	DN	PN	B ₂	H	Z	ΦA	f	U	B ₇	g	EPDM Code	FKM Code
5"	125	10	120	240	64	215.9	3/4"	8	425	9750	FKOALVEL500E	FKOALVEL500F
6"	150	10	134	268	70	241.3	3/4"	8	438	10500	FKOALVEL600E	FKOALVEL600F
8"	200	10	161	323	71	298.4	3/4"	8	485	13200	FKOALVEL800E	FKOALVEL800F

DIMENSIONS

FK/CE DN 40÷400 PVC-U

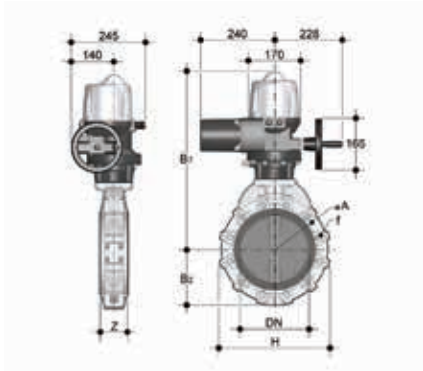

FKOV/CE 24V AC/DC LUG ANSI DN 250-300

LUG ANSI version butterfly valve with electric actuator 24 V AC/DC

d	DN	PN	B ₂	H	Z	ΦA	f	U	B ₁	g	EPDM Code	FKM Code
10"	250	6	210	405	114	362	7/8"	12	555	36800	FKOALVEE810E	FKOALVEE810F
12"	300	6	245	475	114	431.8	7/8"	12	611	43800	FKOALVEE812E	FKOALVEE812F

DIMENSIONS

FK/CE DN 40÷300 PVC-C

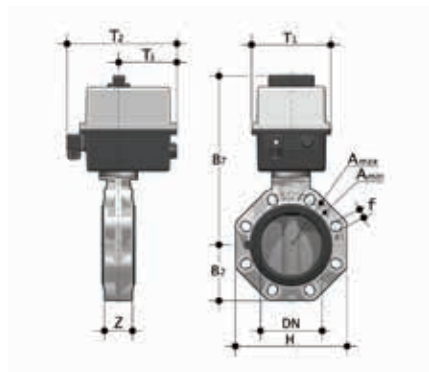

FKOC/CE 90-240V AC DN 40-100

Butterfly valve with multi-volt electric actuator 90-240 V AC 50-60 Hz

d	DN	PN	B ₂	H	Z	A _{min}	A _{max}	f	U	B ₂	T ₁	T ₂	T ₃	g	EPDM Code	FKM Code
50-1 1/2"	40	16	60	132	33	99	109	19	4	253	92	189	91	2124	FKOCEM050E	FKOCEM050F
63-2"	50	16	70	147	43	115	125.5	19	4	259	92	189	91	2320	FKOCEM063E	FKOCEM063F
75-2 1/2"	65	10	80	165	46	128	144	19	4	266	92	189	91	2587	FKOCEM075E	FKOCEM075F
90-3"	80	10	93	185	49	145	160	19	12	308	128	204	95.5	4322	FKOCEM090E	FKOCEM090F
110-4"	100	10	107	211	56	165	190	19	8	322	128	204	95.5	4702	FKOCEM110E	FKOCEM110F

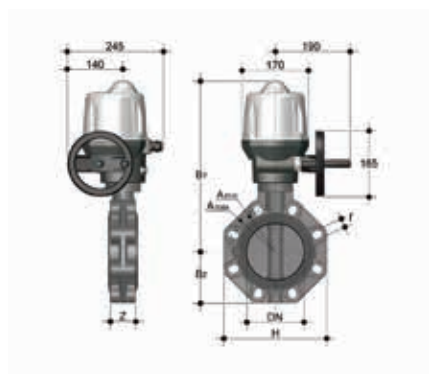

FKOC/CE 90-240V AC DN 125-200

Butterfly valve with multi-volt electric actuator 90-240 V AC 50-60 Hz

d	DN	PN	B ₂	H	Z	A _{min}	A _{max}	f	U	B ₂	g	EPDM Code	FKM Code
140-5"	125	10	120	240	64	204	215	23	8	425	8372	FKOCEM140E	FKOCEM140F
160-6"	150	10	134	268	70	230	242	23	8	438	9187	FKOCEM160E	FKOCEM160F
225-8"	200	10	161	323	71	280	298	23	8	485	12122	FKOCEM225E	FKOCEM225F

DIMENSIONS

FK/CE DN 40÷300 PVC-C

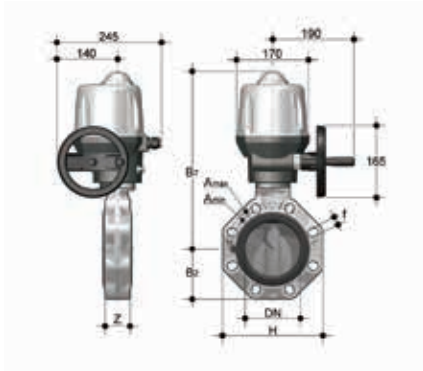

FKOC/CE 90-240V AC DN 250-300

Butterfly valve with multi-volt electric actuator 90-240 V AC 50-60 Hz

d	DN	PN	B ₂	H	Z	ΦA	f	U	B ₇	g	EPDM Code	FKM Code
250/280	*250	10	210	405	114	350	22	12	555	33043	FKOCEA280E	FKOCEA280F
315	*300	8	245	475	114	400	22	12	611	40652	FKOCEA315E	FKOCEA315F
10"	**250	10	210	405	114	362	25.4	12	555	33043	FKOACEA810E	FKOACEA810F
12"	**300	8	245	475	114	432	25.4	12	611	40652	FKOACEA812E	FKOACEA812F

Note: Power supply is 230V AC for DN250-300. Other voltages upon request.
 *ISO-DIN
 **ANSI B.16.5 150

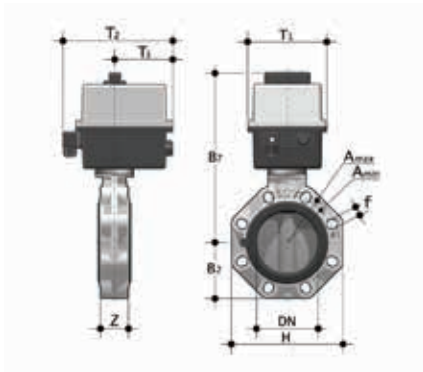

FKOC/CE 24V AC/DC DN 40-100

Butterfly valve with electric actuator 24 V AC/DC

d	DN	PN	B ₂	H	Z	A _{min}	A _{max}	f	U	B ₇	T ₁	T ₂	T ₃	g	EPDM Code	FKM Code
50-1 1/2	40	16	60	132	33	99	109	19	4	253	92	189	91	2124	FKOCEL050E	FKOCEL050F
63-2"	50	16	70	147	43	115	125.5	19	4	259	92	189	91	2320	FKOCEL063E	FKOCEL063F
75-2 1/2	65	10	80	165	46	128	144	19	4	266	92	189	91	2587	FKOCEL075E	FKOCEL075F
90-3"	80	10	93	185	49	145	160	19	12	308	128	204	95.5	4322	FKOCEL090E	FKOCEL090F
110-4"	100	10	107	211	56	165	190	19	8	322	128	204	95.5	4702	FKOCEL110E	FKOCEL110F

12V DA gaskets upon request

DIMENSIONS

FK/CE DN 40÷300 PVC-C

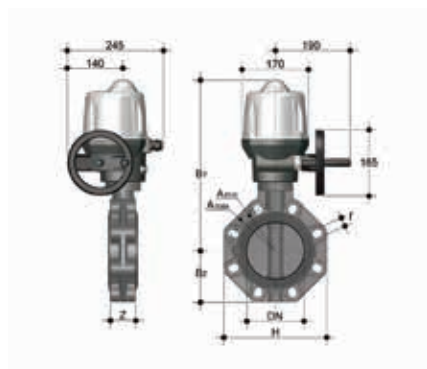

FKOC/CE 24V AC/DC DN 125-200

Butterfly valve with electric actuator 24 V AC/DC

d	DN	PN	B ₂	H	Z	A _{min}	A _{max}	f	U	B ₁	g	EPDM Code	FKM Code
125/140-5"	125	10	120	240	64	204	215	23	8	425	8372	FKOCEL140E	FKOCEL140F
160-6"	150	10	134	268	70	230	242	23	8	438	9187	FKOCEL160E	FKOCEL160F
200/225-8"	200	10	161	323	71	280	298	23	8	485	12122	FKOCEL225E	FKOCEL225F

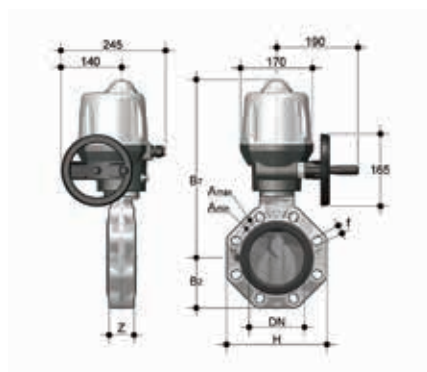

FKOC/CE 24V AC/DC DN 250-300

Butterfly valve with electric actuator 24 V AC/DC

d	DN	PN	B ₂	H	Z	ΦA	f	U	B ₁	g	EPDM Code	FKM Code
250/280	*250	10	210	405	114	350	22	12	555	33043	FKOCEE280E	FKOCEE280F
315	*300	8	245	475	114	400	22	12	611	40652	FKOCEE315E	FKOCEE315F
10"	**250	10	210	405	114	362	25.4	12	555	33043	FKOACEE810E	FKOACEE810F
12"	**300	8	245	475	114	432	25.4	12	611	40652	FKOACEE812E	FKOACEE812F

*ISO-DIN
**ANSI B.16.5 150

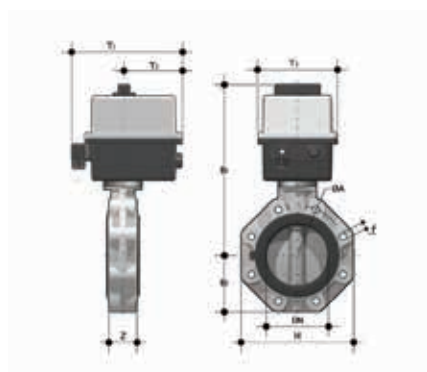

FKOC/CE 90-240V AC LUG ISO-DIN DN 65-100

LUG ISO-DIN version butterfly valve with multi-volt electric actuator 90-240 V AC 50-60 Hz

d	DN	PN	B ₂	H	Z	ΦA	f	U	B ₁	T ₁	T ₂	T ₃	g	EPDM Code	FKM Code
75	65	10	80	165	46	145	M16	4	266	92	189	91	3022	FKOLCEM075E	FKOLCEM075F
90	80	10	93	185	49	160	M16	12	308	128	204	95.5	5191	FKOLCEM090E	FKOLCEM090F
110	100	10	107	211	56	180	M16	8	322	128	204	95.5	5572	FKOLCEM110E	FKOLCEM110F

12V DA gaskets upon request

DIMENSIONS

FK/CE DN 40÷300 PVC-C

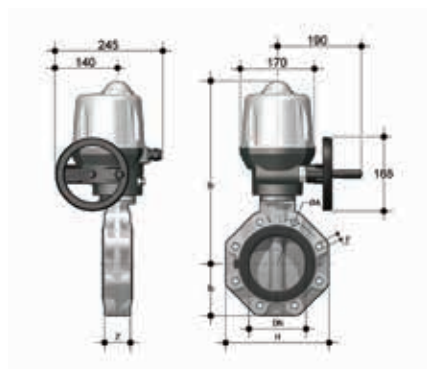

FKOC/CE 90-240V AC LUG ISO-DIN DN 125-200

LUG ISO-DIN version butterfly valve with multi-volt electric actuator 90-240 V AC 50-60 Hz

d	DN	PN	B ₂	H	Z	ΦA	f	U	B ₇	g	EPDM Code	FKM Code
140	125	10	120	240	64	210	M16	8	425	10111	FKOLCEM140E	FKOLCEM140F
160	150	10	134	268	70	240	M20	8	438	10926	FKOLCEM160E	FKOLCEM160F
225	200	10	161	323	71	295	M20	8	485	13861	FKOLCEM225E	FKOLCEM225F

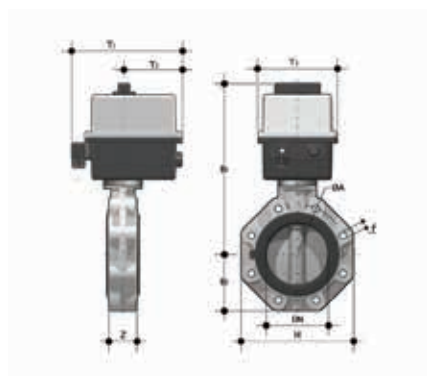

FKOC/CE 24V AC/DC LUG ISO-DIN DN 65-100

LUG ISO-DIN version butterfly valve with electric 24 V AC/DC

d	DN	PN	B ₂	H	Z	ΦA	f	U	B ₇	T ₁	T ₂	T ₃	g	EPDM Code	FKM Code
75	65	10	80	165	46	145	M16	4	266	92	189	91	3022	FKOLCEL075E	FKOLCEL075F
90	80	10	93	185	49	160	M16	12	308	128	204	95.5	5191	FKOLCEL090E	FKOLCEL090F
110	100	10	107	211	56	180	M16	8	322	128	204	95.5	5572	FKOLCEL110E	FKOLCEL110F

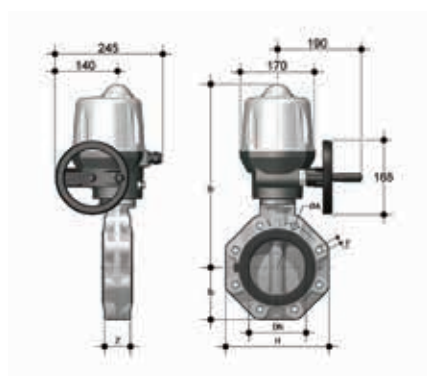

FKOC/CE 24V AC/DC LUG ISO-DIN DN 125-200

LUG ISO-DIN version butterfly valve with electric 24 V AC/DC

d	DN	PN	B ₂	H	Z	ΦA	f	U	B ₇	g	EPDM Code	FKM Code
140	125	10	120	240	64	210	M16	8	425	10111	FKOLCEL140E	FKOLCEL140F
160	150	10	134	268	70	240	M20	8	438	10926	FKOLCEL160E	FKOLCEL160F
225	200	10	161	323	71	295	M20	8	485	13861	FKOLCEL225E	FKOLCEL225F

DIMENSIONS

FK/CE DN 40÷300 PVC-C

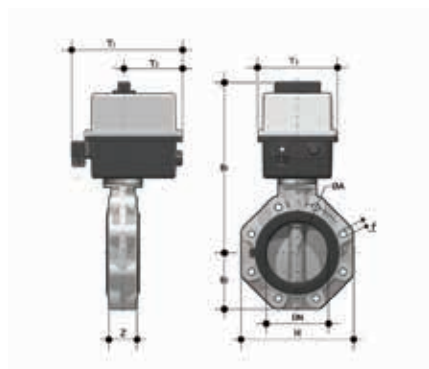

FKOC/CE 90-240V AC LUG ANSI DN 65-100

LUG ANSI 150 version butterfly valve with multi-volt electric actuator 90-240 V AC 50-60 Hz

d	DN	PN	B ₂	H	Z	ΦA	f	U	B ₇	T ₁	T ₂	T ₃	g	EPDM Code	FKM Code
2 1/2"	65	10	80	165	46	139.7	5/8"	4	266	92	189	91	3022	FKOALCEM212E	FKOALCEM212F
3"	80	10	93	185	49	152.4	5/8"	12	308	128	204	95.5	5191	FKOALCEM300E	FKOALCEM300F
4"	100	10	107	211	56	190.5	5/8"	8	322	128	204	95.5	5572	FKOALCEM400E	FKOALCEM400F

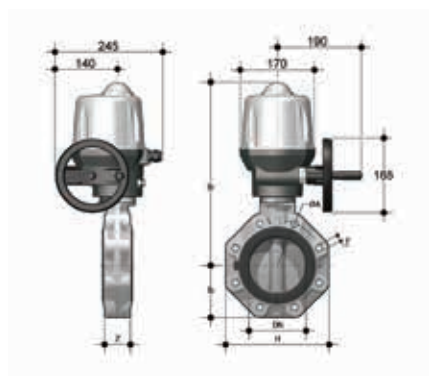

FKOC/CE 90-240V AC LUG ANSI DN 125-200

LUG ANSI 150 version butterfly valve with multi-volt electric actuator 90-240 V AC 50-60 Hz

d	DN	PN	B ₂	H	Z	ΦA	f	U	B ₇	g	EPDM Code	FKM Code
5"	125	10	120	240	64	215.9	3/4"	8	425	10111	FKOALCEM500E	FKOALCEM500F
6"	150	10	134	268	70	241.3	3/4"	8	438	10926	FKOALCEM600E	FKOALCEM600F
8"	200	10	161	323	71	298.4	3/4"	8	485	13861	FKOALCEM800E	FKOALCEM800F

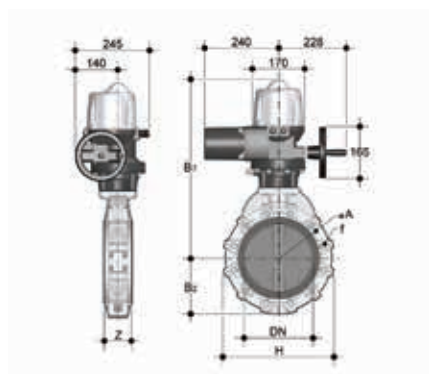

FKOC/CE 90-240V AC LUG ANSI DN 250-300

LUG ANSI 150 version butterfly valve with multi-volt electric actuator 90-240 V AC 50-60 Hz

d	DN	PN	B ₂	H	Z	ΦA	f	U	B ₇	g	EPDM Code	FKM Code
10"	250	6	210	405	114	362	7/8"	12	555	38261	FKOALCEA810E	FKOALCEA810F
12"	300	6	245	475	114	431.8	7/8"	12	611	45870	FKOALCEA812E	FKOALCEA812F

Note: Power supply is 230V AC for DN250-300. Other voltages upon request.

DIMENSIONS

FK/CE DN 40÷300 PVC-C

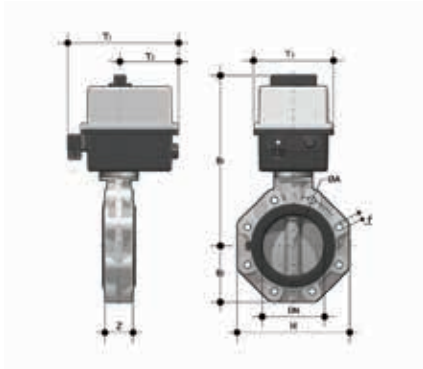

FKOC/CE 24V AC/DC LUG ANSI DN 65-100

LUG ANSI 150 version butterfly valve with electric 24 V AC/DC

d	DN	PN	B ₂	H	Z	ΦA	f	U	B ₇	T ₁	T ₂	T ₃	g	EPDM Code	FKM Code
2 1/2"	65	10	80	165	46	139.7	5/8"	4	266	92	189	91	3022	FKOALCEL212E	FKOALCEL212F
3"	80	10	93	185	49	152.4	5/8"	12	308	128	204	95.5	5191	FKOALCEL300E	FKOALCEL300F
4"	100	10	107	211	56	190.5	5/8"	8	322	128	204	95.5	5572	FKOALCEL400E	FKOALCEL400F

12V DA gaskets upon request

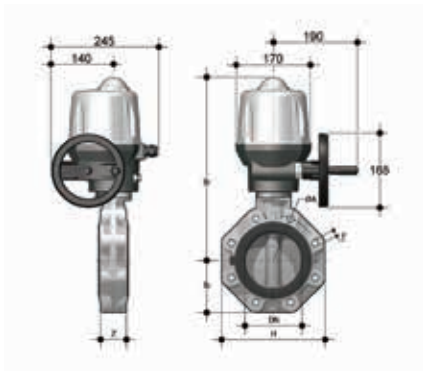

FKOC/CE 24V AC/DC LUG ANSI DN 125-200

LUG ANSI 150 version butterfly valve with electric 24 V AC/DC

d	DN	PN	B ₂	H	Z	ΦA	f	U	B ₇	g	EPDM Code	FKM Code
5"	125	10	120	240	64	215.9	3/4"	8	425	10111	FKOALCEL500E	FKOALCEL500F
6"	150	10	134	268	70	241.3	3/4"	8	438	10926	FKOALCEL600E	FKOALCEL600F
8"	200	10	161	323	71	298.4	3/4"	8	485	13861	FKOALCEL800E	FKOALCEL800F

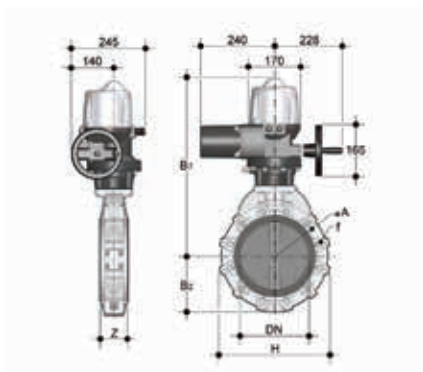

FKOC/CE 24V AC/DC LUG ANSI DN 250-300

LUG ANSI 150 version butterfly valve with electric 24 V AC/DC

d	DN	PN	B ₂	H	Z	ΦA	f	U	B ₇	g	EPDM Code	FKM Code
10"	250	6	210	405	114	362	7/8"	12	555	38261	FKOALCEE810E	FKOALCEE810F
12"	300	6	245	475	114	431.8	7/8"	12	611	45870	FKOALCEE812E	FKOALCEE812F

DIMENSIONS

FK/CE DN 40÷400 PP-H

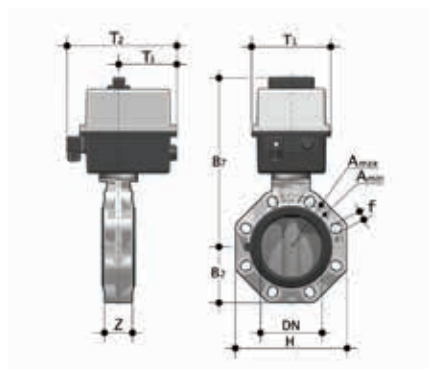

FKOM/CE 90-240V AC DN 40-100

Butterfly valve with multi-volt electric actuator 90-240 V AC 50-60 Hz

d	DN	PN	B ₂	H	Z	A _{min}	A _{max}	f	U	B ₂	T ₁	T ₂	T ₃	g	EPDM Code	FKM Code
50-1 1/2"	40	10	60	132	33	99	109	19	4	253	92	189	91	1974	FKOMEM050E	FKOMEM050F
63-2"	50	10	70	147	43	115	125.5	19	4	259	92	189	91	2154	FKOMEM063E	FKOMEM063F
75-2 1/2"	65	10	80	165	46	128	144	19	4	266	92	189	91	2400	FKOMEM075E	FKOMEM075F
90-3"	80	10	93	185	49	145	160	19	12	308	128	204	95.5	4100	FKOMEM090E	FKOMEM090F
110-4"	100	10	107	211	56	165	190	19	8	322	128	204	95.5	4450	FKOMEM110E	FKOMEM110F



FKOM/CE 90-240V AC DN 125-200

Butterfly valve with multi-volt electric actuator 90-240 V AC 50-60 Hz

d	DN	PN	B ₂	H	Z	A _{min}	A _{max}	f	U	B ₂	g	EPDM Code	FKM Code
140-5"	125	10	120	240	64	204	215	23	8	425	8050	FKOMEM140E	FKOMEM140F
160-6"	150	10	134	268	70	230	242	23	8	438	8800	FKOMEM160E	FKOMEM160F
225-8"	200	10	161	323	71	280	298	23	8	485	11500	FKOMEM225E	FKOMEM225F

The special chamfered stubs QBM from d160 to d315 are available for installation on pipes in PP-H SDR 11 and 17.6

DIMENSIONS

FK/CE DN 40÷400 PP-H

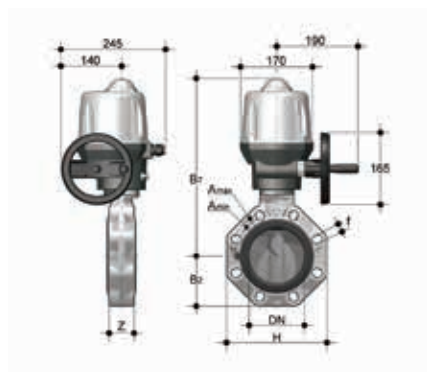

FKOM/CE 90-240V AC DN 250-300

Butterfly valve with multi-volt electric actuator 90-240 V AC 50-60 Hz

d	DN	PN	B ₂	H	Z	ΦA	f	U	B ₂	g	EPDM Code	FKM Code
250/280	*250	10	210	405	114	350	22	12	555	31800	FKOMEA280E	FKOMEA280F
315	*300	8	245	475	114	400	22	12	611	38700	FKOMEA315E	FKOMEA315F
10"	**250	10	210	405	114	362	25.4	12	555	31800	FKOAMEA810E	FKOAMEA810F
12"	**300	8	245	475	114	432	25.4	12	611	38700	FKOAMEA812E	FKOAMEA812F

Note: Power supply is 230V AC for DN250-400. Other voltages upon request
 *ISO-DIN
 **ANSI B.16.5 150

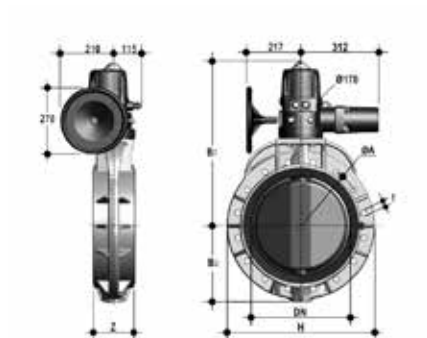

FKOM/CE 90-240V AC DN 350-400

Butterfly valve with multi-volt electric actuator 90-240 V AC 50-60 Hz

d	DN	PN	B ₂	H	Z	ΦA	f	U	B ₂	g	EPDM Code	FKM Code
355	*350	7	280	530	129	460	22	16	636	44315	FKOMEA355E	FKOMEA355F
400	*400	6	306	594	169	515	26	16	656	51310	FKOMEA400E	FKOMEA400F
14"	**350	7	280	530	129	476	28.5	12	636	44315	FKOAMEA814E	FKOAMEA814F
16"	**400	6	306	594	169	540	28.5	16	656	51310	FKOAMEA816E	FKOAMEA816F

*ISO-DIN
 **ANSI B.16.5 150

DIMENSIONS

FK/CE DN 40÷400 PP-H

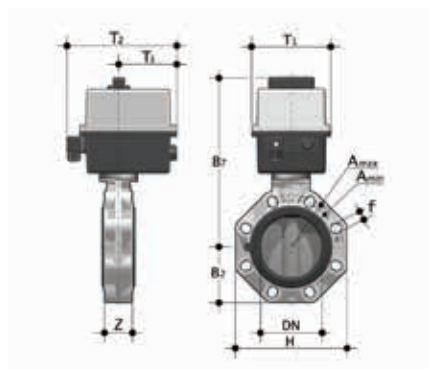

FKOM/CE 24V AC/DC DN 40-100

Butterfly valve with electric actuator 24 V AC/DC

d	DN	PN	B ₂	H	Z	A _{min}	A _{max}	f	U	B ₂	T ₁	T ₂	T ₃	g	EPDM Code	FKM Code
50-1 1/2"	40	10	60	132	33	99	109	19	4	253	92	189	91	1974	FKOMEL050E	FKOMEL050F
63-2"	50	10	70	147	43	115	125.5	19	4	259	92	189	91	2154	FKOMEL063E	FKOMEL063F
75-2 1/2"	65	10	80	165	46	128	144	19	4	266	92	189	91	2400	FKOMEL075E	FKOMEL075F
90-3"	80	10	93	185	49	145	160	19	12	308	128	204	95.5	4100	FKOMEL090E	FKOMEL090F
110-4"	100	10	107	211	56	165	190	19	8	322	128	204	95.5	4450	FKOMEL110E	FKOMEL110F

12V DC gaskets upon request



FKOM/CE 24V AC/DC DN 125-200

Butterfly valve with electric actuator 24 V AC/DC

d	DN	PN	B ₂	H	Z	A _{min}	A _{max}	f	U	B ₂	g	EPDM Code	FKM Code
140-5"	125	10	120	240	64	204	215	23	8	425	8050	FKOMEL140E	FKOMEL140F
160-6"	150	10	134	268	70	230	242	23	8	438	8800	FKOMEL160E	FKOMEL160F
225-8"	200	10	161	323	71	280	298	23	8	485	11500	FKOMEL225E	FKOMEL225F

The special chamfered stubs QBM from d160 to d315 are available for installation on pipes in PP-H SDR 11 and 17.6

DIMENSIONS

FK/CE DN 40÷400 PP-H

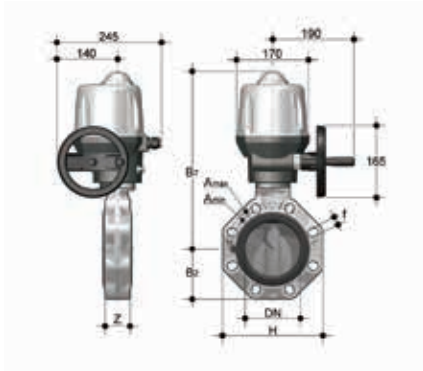

FKOM/CE 24V AC/DC DN 250-300

Butterfly valve with electric actuator 24 V AC/DC

d	DN	PN	B ₂	H	Z	ΦA	f	U	B ₁	g	EPDM Code	FKM Code
250/280	*250	10	210	405	114	350	22	12	555	31800	FKOMEE280E	FKOMEE280F
315	*300	8	245	475	114	400	22	12	611	38700	FKOMEE315E	FKOMEE315F
10"	**250	10	210	405	114	362	25.4	12	555	31800	FKOAMEE810E	FKOAMEE810F
12"	**300	8	245	475	114	432	25.4	12	611	38700	FKOAMEE812E	FKOAMEE812F

Power supply is 24V AC for DN250-400.
*ISO-DIN
**ANSI B.16.5 150

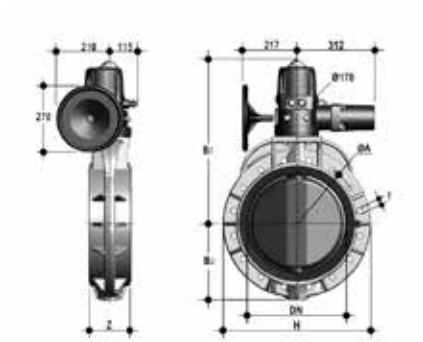

FKOM/CE 24V AC/DC DN 350-400

Butterfly valve with electric actuator 24 V AC/DC

d	DN	PN	B ₂	H	Z	ΦA	f	U	B ₁	g	EPDM Code	FKM Code
355	*350	7	280	530	129	460	22	16	636	44315	FKOMEE355E	FKOMEE355F
400	*400	6	306	594	169	515	26	16	656	51310	FKOMEE400E	FKOMEE400F
14"	**350	7	280	530	129	476	28.5	12	636	44315	FKOAMEE814E	FKOAMEE814F
16"	**400	6	306	594	169	540	28.5	16	656	51310	FKOAMEE816E	FKOAMEE816F

Power supply is 24V AC for DN250-400.
*ISO-DIN
**ANSI B.16.5 150

DIMENSIONS

FK/CE DN 40÷400 PP-H

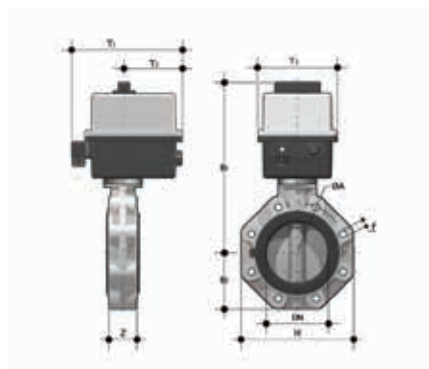

FKOM/CE 90-240V AC LUG ISO-DIN DN 65-100

LUG ISO-DIN version butterfly valve with multi-volt electric actuator 90-240 V AC 50-60 Hz

d	DN	PN	B ₂	H	Z	ΦA	f	U	B ₇	T ₁	T ₂	T ₃	g	EPDM Code	FKM Code
75	65	10	80	165	46	145	M16	4	266	92	189	91	2800	FKOLMEM075E	FKOLMEM075F
90	80	10	93	185	49	160	M16	12	308	128	204	95.5	4900	FKOLMEM090E	FKOLMEM090F
110	100	10	107	211	56	180	M16	8	322	128	204	95.5	5250	FKOLMEM110E	FKOLMEM110F

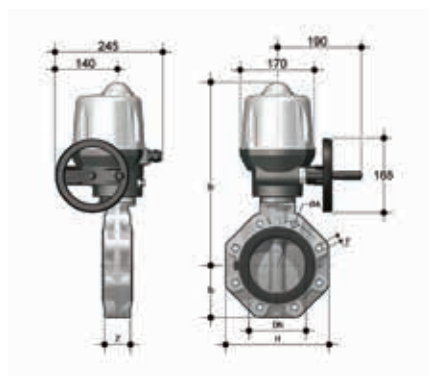

FKOM/CE 90-240V AC LUG ISO-DIN DN 125-200

LUG ISO-DIN version butterfly valve with multi-volt electric actuator 90-240 V AC 50-60 Hz

d	DN	PN	B ₂	H	Z	ΦA	f	U	B ₇	g	EPDM Code	FKM Code
140	125	10	120	240	64	210	M16	8	425	9650	FKOLMEM140E	FKOLMEM140F
160	150	10	134	268	70	240	M20	8	438	10400	FKOLMEM160E	FKOLMEM160F
225	200	10	161	323	71	295	M20	8	485	13100	FKOLMEM225E	FKOLMEM225F

The special chamfered stubs QBM from d160 to d315 are available for installation on pipes in PP-H SDR 11 and 17.6

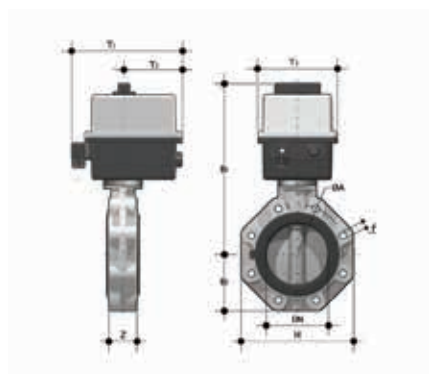

FKOM/CE 24V AC/DC LUG ISO-DIN DN 65-100

LUG ISO-DIN version butterfly valve with electric 24 V AC/DC

d	DN	PN	B ₂	H	Z	ΦA	f	U	B ₇	T ₁	T ₂	T ₃	g	EPDM Code	FKM Code
75	65	10	80	165	46	145	M16	4	266	92	189	91	2800	FKOLMEL075E	FKOLMEL075F
90	80	10	93	185	49	160	M16	12	308	128	204	95.5	4900	FKOLMEL090E	FKOLMEL090F
110	100	10	107	211	56	180	M16	8	322	128	204	95.5	5250	FKOLMEL110E	FKOLMEL110F

DIMENSIONS

FK/CE DN 40÷400 PP-H

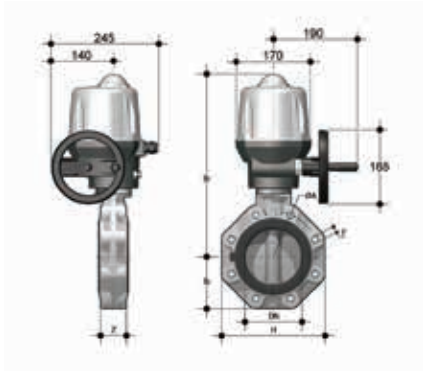

FKOM/CE 24V AC/DC LUG ISO-DIN DN 125-200

LUG ISO-DIN version butterfly valve with electric 24 V AC/DC

d	DN	PN	B ₂	H	Z	ΦA	f	U	B ₇	g	EPDM Code	FKM Code
140	125	10	120	240	64	210	M16	8	425	9650	FKOLMEL140E	FKOLMEL140F
160	150	10	134	268	70	240	M20	8	438	10400	FKOLMEL160E	FKOLMEL160F
225	200	10	161	323	71	295	M20	8	485	13100	FKOLMEL225E	FKOLMEL225F

The special chamfered stubs QBM from d160 to d315 are available for installation on pipes in PP-H SDR 11 and 17.6

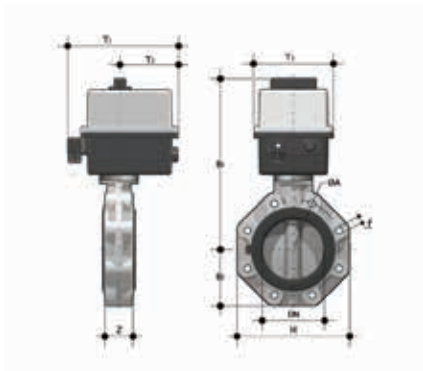

FKOM/CE 90-240V AC LUG ANSI DN 65-100

LUG ANSI 150 version butterfly valve with multi-volt electric actuator 90-240 V AC 50-60 Hz

d	DN	PN	B ₂	H	Z	ΦA	f	U	B ₇	T ₁	T ₂	T ₃	g	EPDM Code	FKM Code
2 1/2"	65	10	80	165	46	139.7	5/8"	4	266	92	189	91	2800	FKOALMEM212E	FKOALMEM212F
3"	80	10	93	185	49	152.4	5/8"	12	308	128	204	95.5	4900	FKOALMEM300E	FKOALMEM300F
4"	100	10	107	211	56	190.5	5/8"	8	322	128	204	95.5	5250	FKOALMEM400E	FKOALMEM400F

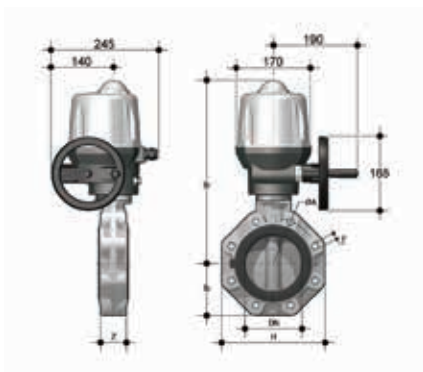

FKOM/CE 90-240V AC LUG ANSI DN 125-200

LUG ANSI 150 version butterfly valve with multi-volt electric actuator 90-240 V AC 50-60 Hz

d	DN	PN	B ₂	H	Z	ΦA	f	U	B ₇	g	EPDM Code	FKM Code
5"	125	10	120	240	64	215.9	3/4"	8	425	9650	FKOALMEM500E	FKOALMEM500F
6"	150	10	134	268	70	241.3	3/4"	8	438	10400	FKOALMEM600E	FKOALMEM600F
8"	200	10	161	323	71	298.4	3/4"	8	485	13100	FKOALMEM800E	FKOALMEM800F

DIMENSIONS

FK/CE DN 40÷400 PP-H

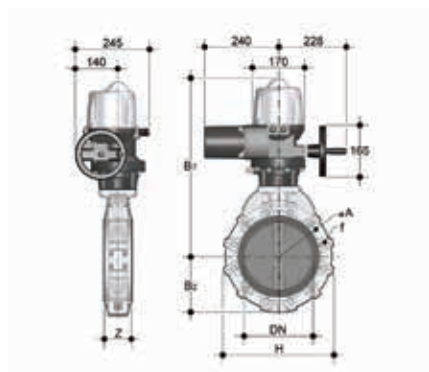

FKOM/CE 90-240V AC LUG ANSI DN 250-300

LUG ANSI 150 version butterfly valve with multi-volt electric actuator 90-240 V AC 50-60 Hz

d	DN	PN	B ₂	H	Z	ΦA	f	U	B ₇	g	EPDM Code	FKM Code
10"	250	6	210	405	114	362	7/8"	12	555	36600	FKOALMEA810E	FKOALMEA810F
12"	300	6	245	475	114	431.8	7/8"	12	611	43500	FKOALMEA812E	FKOALMEA812F

Power supply is 230V AC for DN250-300. Other voltages upon request.

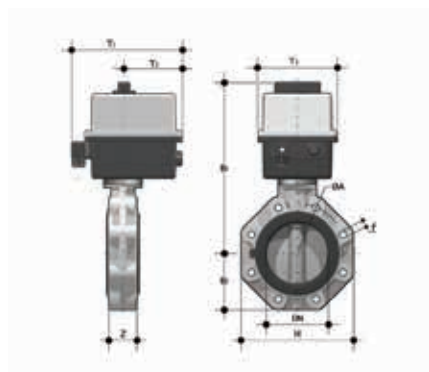

FKOM/CE 24V AC/DC LUG ANSI DN 65-100

LUG ANSI 150 version butterfly valve with electric 24 V AC/DC

d	DN	PN	B ₂	H	Z	ΦA	f	U	B ₇	T ₁	T ₂	T ₃	g	EPDM Code	FKM Code
2 1/2"	65	10	80	165	46	139.7	5/8"	4	266	92	189	91	2800	FKOALMEL212E	FKOALMEL212F
3"	80	10	93	185	49	152.4	5/8"	12	308	128	204	95.5	4900	FKOALMEL300E	FKOALMEL300F
4"	100	10	107	211	56	190.5	5/8"	8	322	128	204	95.5	5250	FKOALMEL400E	FKOALMEL400F

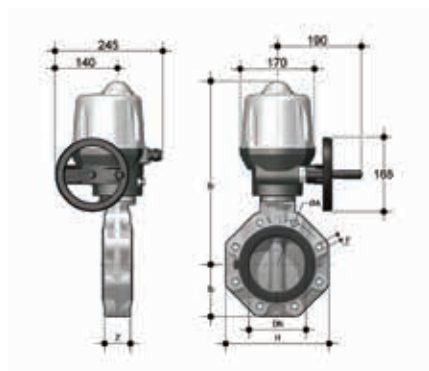

FKOM/CE 24V AC/DC LUG ANSI DN 125-200

LUG ANSI 150 version butterfly valve with electric 24 V AC/DC

d	DN	PN	B ₂	H	Z	ΦA	f	U	B ₇	g	EPDM Code	FKM Code
5"	125	10	120	240	64	215.9	3/4"	8	425	9650	FKOALMEL500E	FKOALMEL500F
6"	150	10	134	268	70	241.3	3/4"	8	438	10400	FKOALMEL600E	FKOALMEL600F
8"	200	10	161	323	71	298.4	3/4"	8	485	13100	FKOALMEL800E	FKOALMEL800F

DIMENSIONS

FK/CE DN 40÷400 PP-H

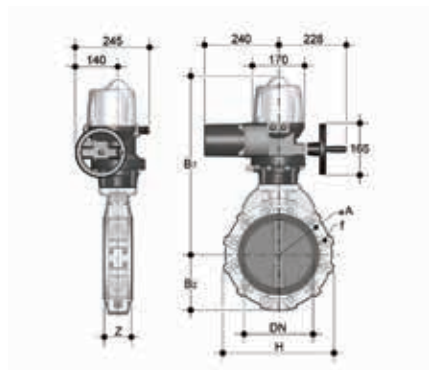

FKOM/CE 24V AC/DC LUG ANSI DN 250-300

LUG ANSI 150 version butterfly valve with electric 24 V AC/DC

d	DN	PN	B ₂	H	Z	ΦA	f	U	B ₁	g	EPDM Code	FKM Code
10"	250	6	210	405	114	362	7/8"	12	555	36600	FKOALMEE810E	FKOALMEE810F
12"	300	6	245	475	114	431.8	7/8"	12	611	43500	FKOALMEE812E	FKOALMEE812F

Power supply is 24V AC for DN250-300.

DIMENSIONS

FK/CE DN 40÷400 PVDF

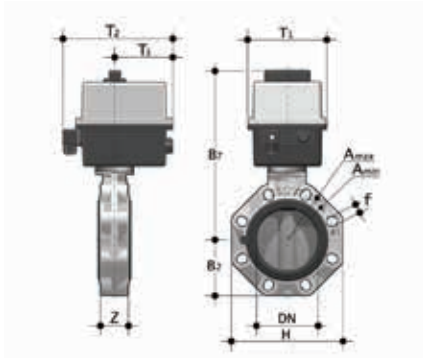

FKOF/CE 90-240V AC DN 40-100

Butterfly valve with multi-volt electric actuator 90-240 V AC 50-60 Hz

d	DN	PN	B ₂	H	Z	A _{min}	A _{max}	f	U	B ₇	T ₁	T ₂	T ₃	g	FKM Code
50-1 1/2"	40	16	60	132	33	99	109	19	4	253	92	189	91	2174	FKOFEM050F
63-2"	50	16	70	147	43	115	125.5	19	4	259	92	189	91	2354	FKOFEM063F
75-2 1/2"	65	10	80	165	46	128	144	19	4	266	92	189	91	2600	FKOFEM075F
90-3"	80	10	93	185	49	145	160	19	12	308	128	204	95.5	4350	FKOFEM090F
110-4"	100	10	107	211	56	165	190	19	8	322	128	204	95.5	4700	FKOFEM110F

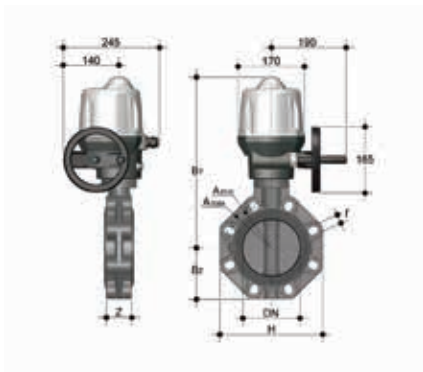

FKOF/CE 90-240V AC DN 125-200

Butterfly valve with multi-volt electric actuator 90-240 V AC 50-60 Hz

d	DN	PN	B ₂	H	Z	A _{min}	A _{max}	f	U	B ₇	g	FKM Code
140-5"	125	10	120	240	64	204	215	23	8	425	8350	FKOFEM140F
160-6"	150	10	134	268	70	230	242	23	8	438	9150	FKOFEM160F
225-8"	200	10	161	323	71	280	298	23	8	485	11900	FKOFEM225F

DIMENSIONS

FK/CE DN 40÷400 PVDF

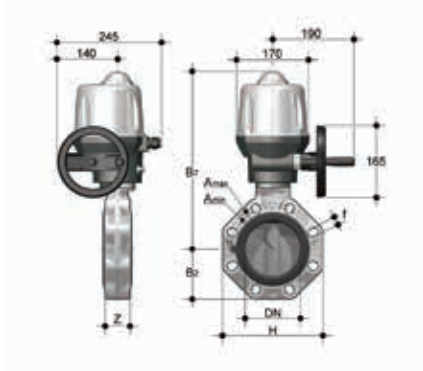

FKOF/CE 90-240V AC DN 250-300

Butterfly valve with multi-volt electric actuator 90-240 V AC 50-60 Hz

d	DN	PN	B ₂	H	Z	ΦA	f	U	B ₁	g	FKM Code
250/280	*250	10	210	405	114	350	22	12	555	33000	FKOFEA280F
315	*300	8	245	475	114	400	22	12	611	41000	FKOFEA315F
10"	**250	10	210	405	114	362	25.4	12	555	33000	FKOAFEA810F
12"	**300	8	245	475	114	432	25.4	12	611	41000	FKOAFEA812F

Power supply is 230V AC for DN250-400. Other voltages upon request.

*ISO-DIN

**ANSI B.16.5 150

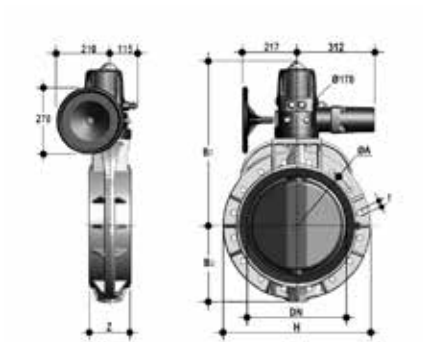

FKOF/CE 90-240V AC DN 350-400

Butterfly valve with multi-volt electric actuator 90-240 V AC 50-60 Hz

d	DN	PN	B ₂	H	Z	ΦA	f	U	B ₁	g	FKM Code
355	*350	7	280	530	129	460	22	16	636	49395	FKOFEA355F
400	*400	6	306	594	169	515	26	16	656	58295	FKOFEA400F
14"	**350	7	280	530	129	476	28.5	12	636	49395	FKOAFEA814F
16"	**400	6	306	594	169	540	28.5	16	656	58295	FKOAFEA816F

Power supply is 230V AC for DN250-400. Other voltages upon request.

*ISO-DIN

**ANSI B.16.5 150

DIMENSIONS

FK/CE DN 40÷400 PVDF

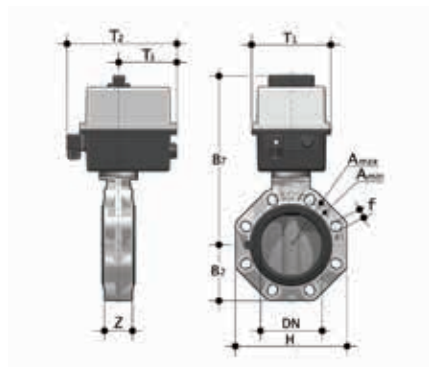

FKOF/CE 24V AC/DC DN 40-100

Butterfly valve with electric actuator 24 V AC/DC

d	DN	PN	B ₂	H	Z	A _{min}	A _{max}	f	U	B ₇	T ₁	T ₂	T ₃	g	FKM Code
50-1"1/2	40	16	60	132	33	99	109	19	4	253	92	189	91	2174	FKOFEL050F
63-2"	50	16	70	147	43	115	125.5	19	4	259	92	189	91	2354	FKOFEL063F
75-2"1/2	65	10	80	165	46	128	144	19	4	266	92	189	91	2600	FKOFEL075F
90-3"	80	10	93	185	49	145	160	19	12	308	128	204	95.5	4350	FKOFEL090F
110-4"	100	10	107	211	56	165	190	19	8	322	128	204	95.5	4700	FKOFEL110F

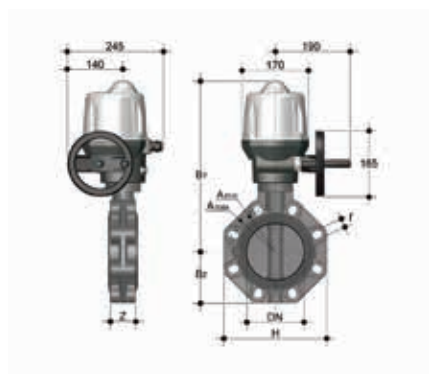

FKOF/CE 24V AC/DC DN 125-200

Butterfly valve with electric actuator 24 V AC/DC

d	DN	PN	B ₂	H	Z	A _{min}	A _{max}	f	U	B ₇	g	FKM Code
140-5"	125	10	120	240	64	204	215	23	8	425	8350	FKOFEL140F
160-6"	150	10	134	268	70	230	242	23	8	438	9150	FKOFEL160F
225-8"	200	10	161	323	71	280	298	23	8	485	11900	FKOFEL225F

DIMENSIONS

FK/CE DN 40÷400 PVDF

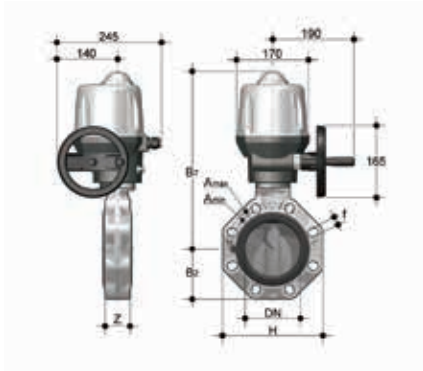

FKOF/CE 24V AC/DC DN 250-300

Butterfly valve with electric actuator 24 V AC/DC

d	DN	PN	B ₂	H	Z	ΦA	f	U	B ₁	g	FKM Code
250/280	*250	10	210	405	114	350	22	12	555	33000	FKOFEE280F
315	*300	8	245	475	114	400	22	12	611	41000	FKOFEE315F
10"	**250	10	210	405	114	362	25.4	12	555	33000	FKOAFEE810F
12"	**300	8	245	475	114	432	25.4	12	611	41000	FKOAFEE812F

Power supply is 230V AC for DN250-400. Other voltages upon request.

*ISO-DIN

**ANSI B16.5 cl.150

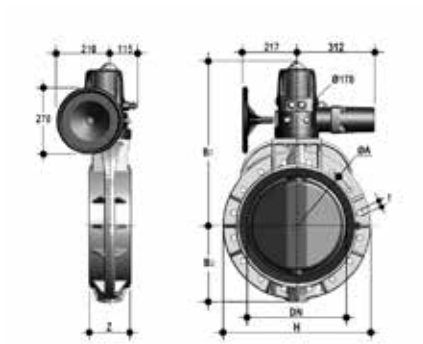

FKOF/CE 24V AC/DC DN 350-400

Butterfly valve with electric actuator 24 V AC/DC

d	DN	PN	B ₂	H	Z	ΦA	f	U	B ₁	g	FKM Code
355	*350	7	280	530	129	460	22	16	636	49395	FKOFEE355F
400	*400	6	306	594	169	515	26	16	656	58295	FKOFEE400F
14"	**350	7	280	530	129	476	28.5	12	636	49395	FKOAFEE814F
16"	**400	6	306	594	169	540	28.5	16	656	58295	FKOAFEE816F

Power supply is 230V AC for DN250-400. Other voltages upon request.

*ISO-DIN

**ANSI B16.5 cl.150

DIMENSIONS

FK/CE DN 40÷400 PVDF

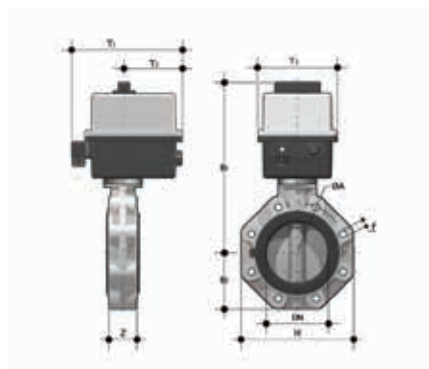

FKOF/CE 90-240V AC LUG ISO-DIN DN 65-100

LUG ISO-DIN version butterfly valve with multi-volt electric actuator 90-240 V AC 50-60 Hz

d	DN	PN	B ₂	H	Z	ΦA	f	U	B ₂	T ₁	T ₂	T ₃	g	FKM Code
75	65	10	80	165	46	145	M16	4	266	92	189	91	3000	FKOLFEM075F
90	80	10	93	185	49	160	M16	12	308	128	204	95.5	5150	FKOLFEM090F
110	100	10	107	211	56	180	M16	8	322	128	204	95.5	5500	FKOLFEM110F

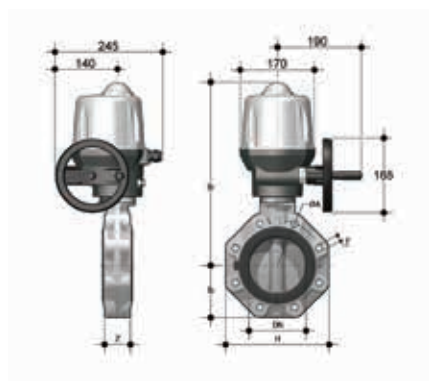

FKOF/CE 90-240V AC LUG ISO-DIN DN 125-200

LUG ISO-DIN version butterfly valve with multi-volt electric actuator 90-240 V AC 50-60 Hz

d	DN	PN	B ₂	H	Z	ΦA	f	U	B ₂	g	FKM Code
140	125	10	120	240	64	210	M16	8	425	9950	FKOLFEM140F
160	150	10	134	268	70	240	M20	8	438	10750	FKOLFEM160F
225	200	10	161	323	71	295	M20	8	485	13500	FKOLFEM225F

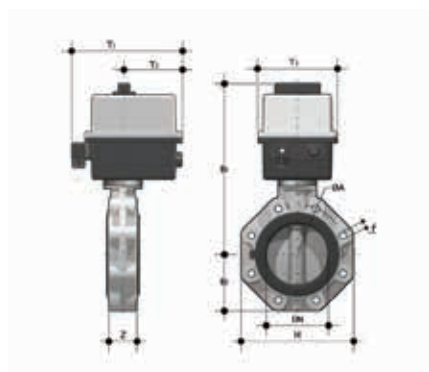

FKOF/CE 24V AC/DC LUG ISO-DIN DN 65-100

LUG ISO-DIN version butterfly valve with electric 24 V AC/DC

d	DN	PN	B ₂	H	Z	ΦA	f	U	B ₂	T ₁	T ₂	T ₃	g	FKM Code
75	65	10	80	165	46	145	M16	4	266	92	189	91	3000	FKOLFEL075F
90	80	10	93	185	49	160	M16	12	308	128	204	95.5	5150	FKOLFEL090F
110	100	10	107	211	56	180	M16	8	322	128	204	95.5	5500	FKOLFEL110F

12V DC gaskets upon request

DIMENSIONS

FK/CE DN 40÷400 PVDF

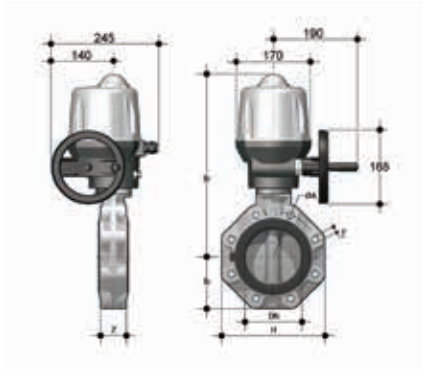

FKOF/CE 24V AC/DC LUG ISO-DIN DN 125-200

LUG ISO-DIN version butterfly valve with electric 24 V AC/DC

d	DN	PN	B ₂	H	Z	ΦA	f	U	B ₁	g	FKM Code
140	125	10	120	240	64	210	M16	8	425	9950	FKOLFEL140F
160	150	10	134	268	70	240	M20	8	438	10750	FKOLFEL160F
225	200	10	161	323	71	295	M20	8	485	13500	FKOLFEL225F

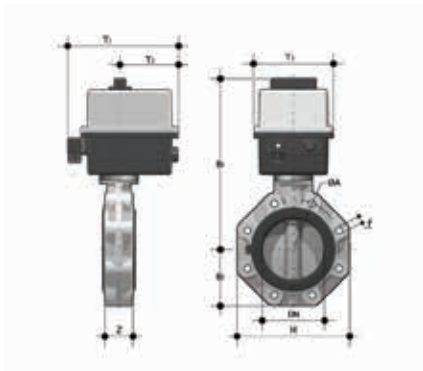

FKOF/CE 90-240V AC LUG ANSI DN 65-100

LUG ANSI version butterfly valve with multi-volt electric actuator 90-240 V AC 50-60 Hz

d	DN	PN	B ₂	H	Z	ΦA	f	U	B ₁	T ₁	T ₂	T ₃	g	FKM Code
2 1/2"	65	10	80	165	46	139.7	5/8"	4	266	92	189	91	3000	FKOALFEM212F
3"	80	10	93	185	49	152.4	5/8"	12	308	128	204	95.5	5150	FKOALFEM300F
4"	100	10	107	211	56	190.5	5/8"	8	322	128	204	95.5	5500	FKOALFEM400F

12V DC gaskets upon request

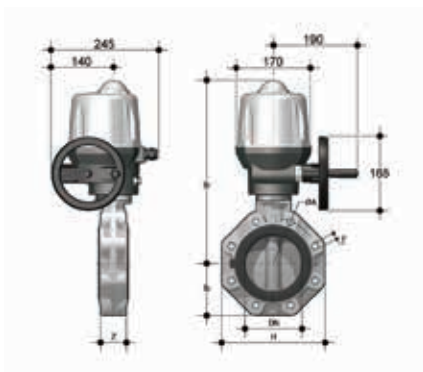

FKOF/CE 90-240V AC LUG ANSI DN 125-200

LUG ANSI version butterfly valve with multi-volt electric actuator 90-240 V AC 50-60 Hz

d	DN	PN	B ₂	H	Z	ΦA	f	U	B ₁	g	FKM Code
5"	125	10	120	240	64	215.9	3/4"	8	425	9950	FKOALFEM500F
6"	150	10	134	268	70	241.3	3/4"	8	438	10750	FKOALFEM600F
8"	200	10	161	323	71	298.4	3/4"	8	485	13500	FKOALFEM800F

DIMENSIONS

FK/CE DN 40÷400 PVDF

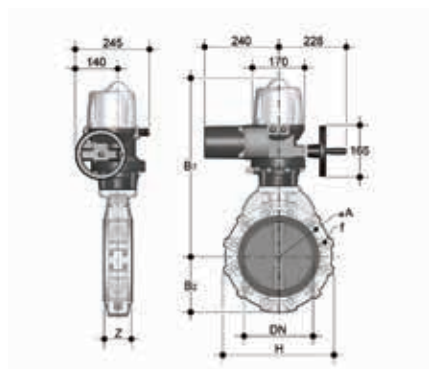

FKOF/CE 90-240V AC LUG ANSI DN 250-300

LUG ANSI version butterfly valve with multi-volt electric actuator 90-240 V AC 50-60 Hz

d	DN	PN	B ₂	H	Z	ΦA	f	U	B ₁	g	FKM Code
10"	250	6	210	405	114	362	7/8"	12	555	37800	FKOALFEA810F
12"	300	6	245	475	114	431.8	7/8"	12	611	45800	FKOALFEA812F

Power supply is 230V AC for DN250-300. Other voltages upon request.

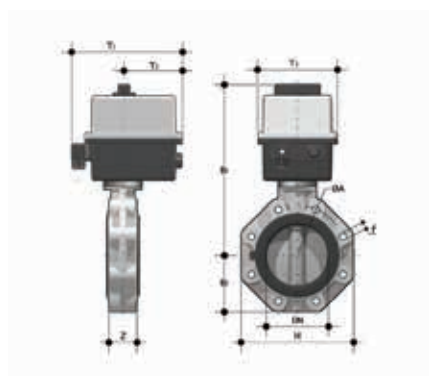

FKOF/CE 24V AC/DC LUG ANSI DN 65-100

LUG ANSI version butterfly valve with electric actuator 24 V AC/DC

d	DN	PN	B ₂	H	Z	ΦA	f	U	B ₁	T ₁	T ₂	T ₃	g	FKM Code
2 1/2"	65	10	80	165	46	139.7	5/8"	4	266	92	189	91	3000	FKOALFEL212F
3"	80	10	93	185	49	152.4	5/8"	12	308	128	204	95.5	5150	FKOALFEL300F
4"	100	10	107	211	56	190.5	5/8"	8	322	128	204	95.5	5500	FKOALFEL400F

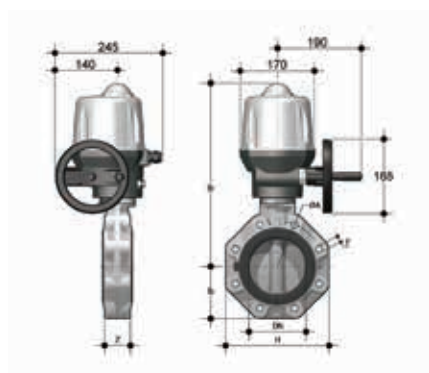

FKOF/CE 24V AC/DC LUG ANSI DN 125-200

LUG ANSI version butterfly valve with electric actuator 24 V AC/DC

d	DN	PN	B ₂	H	Z	ΦA	f	U	B ₁	g	FKM Code
5"	125	10	120	240	64	215.9	3/4"	8	425	9950	FKOALFEL500F
6"	150	10	134	268	70	241.3	3/4"	8	438	10750	FKOALFEL600F
8"	200	10	161	323	71	298.4	3/4"	8	485	13500	FKOALFEL800F

DIMENSIONS

FK/CE DN 40÷400 PVDF

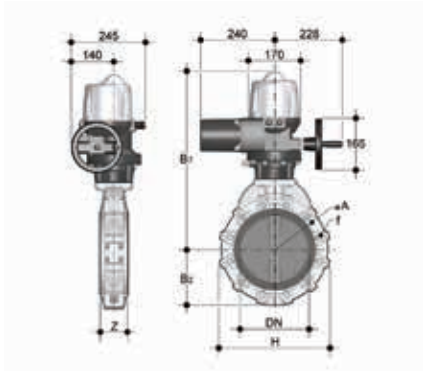

FKOF/CE 24V AC/DC LUG ANSI DN 250-300

LUG ANSI version butterfly valve with electric actuator 24 V AC/DC

d	DN	PN	B ₂	H	Z	ΦA	f	U	B ₂	g	FKM Code
10"	250	6	210	405	114	362	7/8"	12	555	37800	FKOALFEE810F
12"	300	6	245	475	114	431.8	7/8"	12	611	45800	FKOALFEE812F

Power supply is 24V AC for DN250-300.

DIMENSIONS

FK/CP DN 40÷400 PVC-U

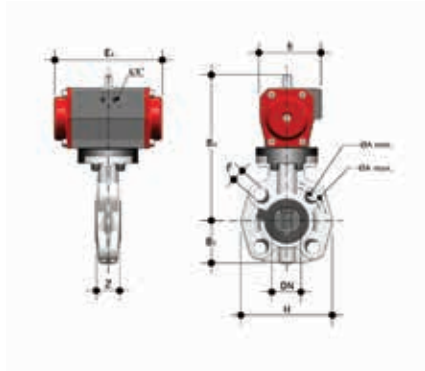

FKOV/CP DA DN 40-65

Butterfly valve with pneumatic actuator, Double-Acting function

d	DN	PN	B ₂	H	Z	A _{min}	A _{max}	f	U	B ₄	E	E ₁	g	EPDM Code	FKM Code
50-1 1/2"	40	16	60	132	33	99	109	19	4	209	86	155	2170	FKOVDA050E	FKOVDA050F
63-2"	50	16	70	147	43	115	125.5	19	4	215	86	155	2350	FKOVDA063E	FKOVDA063F
75-2 1/2"	65	10	80	165	46	128	144	19	4	222	86	155	2600	FKOVDA075E	FKOVDA075F

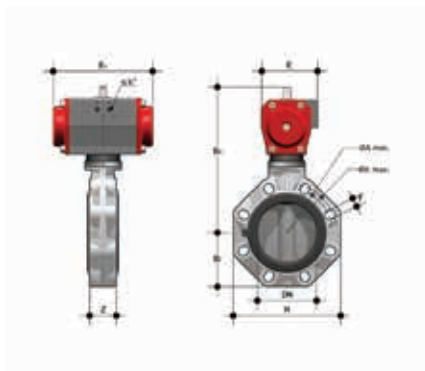

FKOV/CP DA DN 80-200

Butterfly valve with pneumatic actuator, Double-Acting function

d	DN	PN	B ₂	H	Z	A _{min}	A _{max}	f	U	B ₄	E	E ₁	g	EPDM Code	FKM Code
90-3"	80	10	93	185	49	145	160	19	12	253	94	210	4300	FKOVDA090E	FKOVDA090F
110-4"	100	10	107	211	56	165	190	19	8	110	104	228	5950	FKOVDA110E	FKOVDA110F
*125/140-5"	125	10	120	240	64	204	215	23	8	297	104	228	6750	FKOVDA140E	FKOVDA140F
160-6"	150	10	134	268	70	230	242	23	8	325	120	280	9100	FKOVDA160E	FKOVDA160F
**200/225-8"	200	10	161	323	71	280	298	23	8	399	134	310	15200	FKOVDA225E	FKOVDA225F

* FKOV d140 with special adapter collars d125
 ** FKOV d225 with special adapter collars d200

DIMENSIONS

FK/CP DN 40÷400 PVC-U

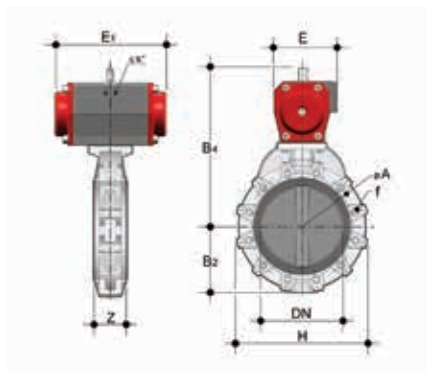

FKOV/CP DA DN 250-300

Butterfly valve with pneumatic actuator, Double-Acting function

d	DN	PN	B ₂	H	Z	ΦA	f	U	B ₂	E	E ₁	g	EPDM Code	FKM Code
250/280	***250	10	210	405	114	350	22	12	453	163	390	27500	FKOVDA280E	FKOVDA280F
315	***300	8	245	475	114	400	22	12	510	163	390	34500	FKOVDA315E	FKOVDA315F
10"	***250	10	210	405	114	362	25.4	12	453	163	390	27500	FKOAVDA810E	FKOAVDA810F
12"	***300	8	245	475	114	432	25.4	12	510	163	390	34500	FKOAVDA812E	FKOAVDA812F

***ISO-DIN
 ****ANSI B.16.5 150

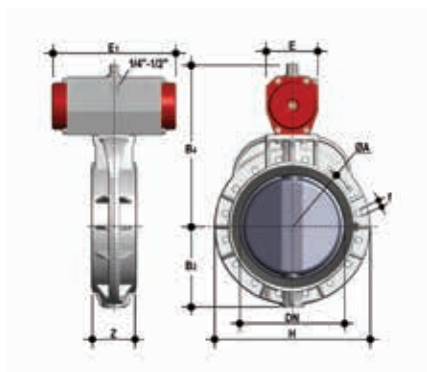

FKOV/CP DA DN 350-400

Butterfly valve with pneumatic actuator, Double-Acting function

d	DN	PN	B ₂	H	Z	ΦA	f	U	B ₂	E	E ₁	g	EPDM Code	FKM Code
355	***350	7	280	530	129	460	22	16	550	196	474	56500	FKOVDA355E	FKOVDA355F
400	***400	6	306	594	169	515	26	16	570	196	474	64500	FKOVDA400E	FKOVDA400F
14"	***350	7	280	530	129	476	28.5	12	550	196	474	56500	FKOAVDA814E	FKOAVDA814F
16"	***400	6	306	594	169	540	28.5	16	570	196	474	64500	FKOAVDA816E	FKOAVDA816F

***ISO-DIN
 ****ANSI B.16.5 150

DIMENSIONS

FK/CP DN 40÷400 PVC-U

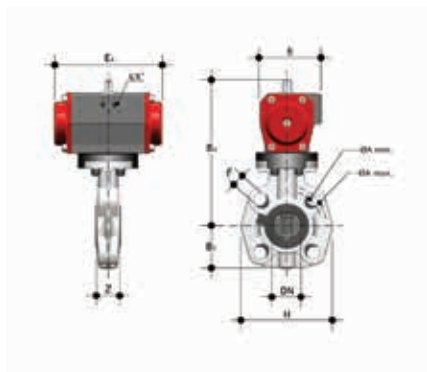

FKOV/CP NC DN 40-65

Butterfly valve with pneumatic actuator, Normally Closed function

d	DN	PN	B ₂	H	Z	A _{min}	A _{max}	f	U	B ₄	E	E ₁	g	EPDM Code	FKM Code
50-1 1/2"	40	16	60	132	33	99	109	19	4	209	86	155	2370	FKOVNC050E	FKOVNC050F
63-2"	50	16	70	147	43	115	125.5	19	4	232	94	210	4120	FKOVNC063E	FKOVNC063F
75-2 1/2"	65	10	80	165	46	128	144	19	4	239	94	210	4400	FKOVNC075E	FKOVNC075F



FKOV/CP NC DN 80-200

Butterfly valve with pneumatic actuator, Normally Closed function

d	DN	PN	B ₂	H	Z	A _{min}	A _{max}	f	U	B ₄	E	E ₁	g	EPDM Code	FKM Code
90-3"	80	10	93	185	49	145	160	19	12	263	104	228	6200	FKOVNC090E	FKOVNC090F
110-4"	100	10	107	211	56	165	190	19	8	292	120	280	8550	FKOVNC110E	FKOVNC110F
*125/140-5"	125	10	120	240	64	204	215	23	8	339	134	310	12850	FKOVNC140E	FKOVNC140F
160-6"	150	10	134	268	70	230	242	23	8	352	134	310	13600	FKOVNC160E	FKOVNC160F
**200/225-8"	200	10	161	323	71	280	298	23	8	473	176	462	35300	FKOVNC225E	FKOVNC225F

* FKOV d140 with special adapter collars d125
 ** FKOV d225 with special adapter collars d200

DIMENSIONS

FK/CP DN 40÷400 PVC-U

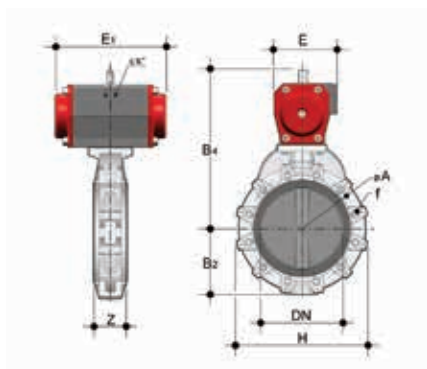

FKOV/CP NC DN 250-300

Butterfly valve with pneumatic actuator, Normally Closed function

d	DN	PN	B ₂	H	Z	ΦA	f	U	B ₄	E	E ₁	g	EPDM Code	FKM Code
250/280	***250	10	210	405	114	350	22	12	538	220	575	65000	FKOVNC280E	FKOVNC280F
315	***300	8	245	475	114	400	22	12	595	220	575	72000	FKOVNC315E	FKOVNC315F
10"	****250	10	210	405	114	362	25.4	12	538	220	575	65000	FKOAVNC810E	FKOAVNC810F
12"	****300	8	245	475	114	432	25.4	12	595	220	575	72000	FKOAVNC812E	FKOAVNC812F

***ISO-DIN
****ANSI B.16.5 150

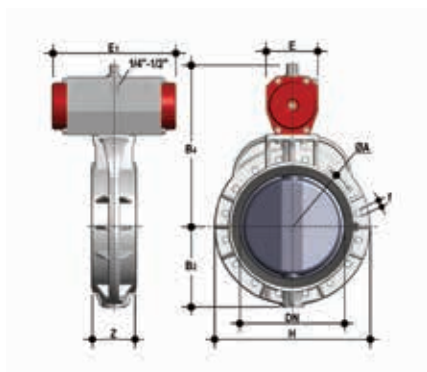

FKOV/CP NC DN 350-400

Butterfly valve with pneumatic actuator, Normally Closed function

d	DN	PN	B ₂	H	Z	ΦA	f	U	B ₄	E	E ₁	g	EPDM Code	FKM Code
355	***350	7	280	530	129	460	22	16	628	300	604	100400	FKOVNC355E	FKOVNC355F
400	***400	6	306	594	169	515	26	16	648	300	604	108400	FKOVNC400E	FKOVNC400F
14"	****350	7	280	530	129	476	28.5	12	628	300	604	100400	FKOAVNC814E	FKOAVNC814F
16"	****400	6	306	594	169	540	28.5	16	648	300	604	108400	FKOAVNC816E	FKOAVNC816F

***ISO-DIN
****ANSI B.16.5 150

DIMENSIONS

FK/CP DN 40÷400 PVC-U

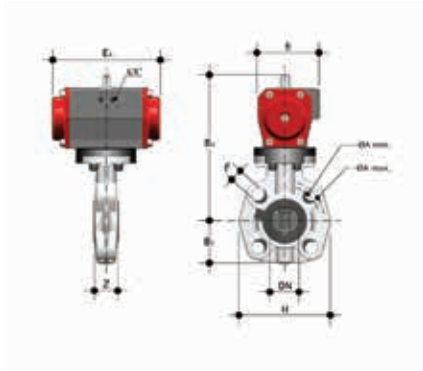

FKOV/CP NO DN 40-65

Butterfly valve with pneumatic actuator, Normally Open function

d	DN	PN	B ₂	H	Z	A _{min}	A _{max}	f	U	B ₄	E	E ₁	g	EPDM Code	FKM Code
50-1 1/2"	40	16	60	132	33	99	109	19	4	209	86	155	2370	FKOVNO050E	FKOVNO050F
63-2"	50	16	70	147	43	115	125.5	19	4	232	94	210	4120	FKOVNO063E	FKOVNO063F
75-2 1/2"	65	10	80	165	46	128	144	19	4	239	94	210	4400	FKOVNO075E	FKOVNO075F

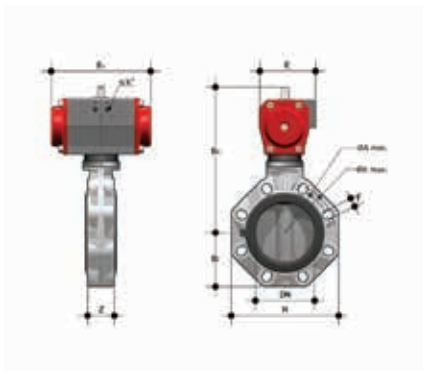

FKOV/CP NO DN 80-200

Butterfly valve with pneumatic actuator, Normally Open function

d	DN	PN	B ₂	H	Z	A _{min}	A _{max}	f	U	B ₄	E	E ₁	g	EPDM Code	FKM Code
90-3"	80	10	93	185	49	145	160	19	12	263	104	228	6200	FKOVNO090E	FKOVNO090F
110-4"	100	10	107	211	56	165	190	19	8	292	120	280	8550	FKOVNO110E	FKOVNO110F
*125/140-5"	125	10	120	240	64	204	215	23	8	339	134	310	12850	FKOVNO140E	FKOVNO140F
160-6"	150	10	134	268	70	230	242	23	8	352	134	310	13600	FKOVNO160E	FKOVNO160F
**200/225-8"	200	10	161	323	71	280	298	23	8	473	176	462	35300	FKOVNO225E	FKOVNO225F

* FKOV d140 with special adapter collars d125
 ** FKOV d225 with special adapter collars d200

DIMENSIONS

FK/CP DN 40÷400 PVC-U

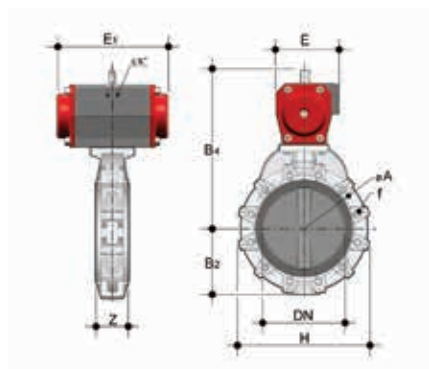

FKOV/CP NO DN 250-300

Butterfly valve with pneumatic actuator, Normally Open function

d	DN	PN	B ₂	H	Z	ΦA	f	U	B ₄	E	E ₁	g	EPDM Code	FKM Code
250/280	***250	10	210	405	114	350	22	12	538	220	575	65000	FKOVNO280E	FKOVNO280F
315	***300	8	245	475	114	400	22	12	595	220	575	72000	FKOVNO315E	FKOVNO315F
10"	****250	10	210	405	114	362	25.4	12	538	220	575	65000	FKOAVNO810E	FKOAVNO810F
12"	****300	8	245	475	114	432	25.4	12	595	220	575	72000	FKOAVNO812E	FKOAVNO812F

***ISO-DIN
****ANSI B.16.5 150

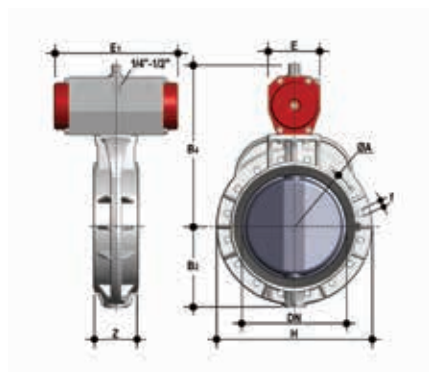

FKOV/CP NO DN 350-400

Butterfly valve with pneumatic actuator, Normally Open function

d	DN	PN	B ₂	H	Z	ΦA	f	U	B ₄	E	E ₁	g	EPDM Code	FKM Code
355	***350	7	280	530	129	460	22	16	628	300	604	98000	FKOVNO355E	FKOVNO355F
400	***400	6	306	594	169	515	26	16	648	300	604	106000	FKOVNO400E	FKOVNO400F
14"	****350	7	280	530	129	476	28.5	12	628	300	604	98000	FKOAVNO814E	FKOAVNO814F
16"	****400	6	306	594	169	540	28.5	16	648	300	604	106000	FKOAVNO816E	FKOAVNO816F

***ISO-DIN
****ANSI B.16.5 150

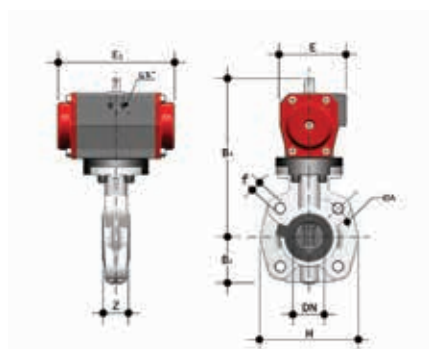

FKOV/CP DA LUG ISO-DIN DN 65

LUG ISO-DIN version butterfly valve with pneumatic actuator Double-Acting function

d	DN	PN	B ₂	H	Z	ΦA	f	U	B ₄	E	E ₁	g	EPDM Code	FKM Code
75	65	10	80	165	46	145	M16	4	222	86	155	3000	FKOLVDA075E	FKOLVDA075F

DIMENSIONS

FK/CP DN 40÷400 PVC-U

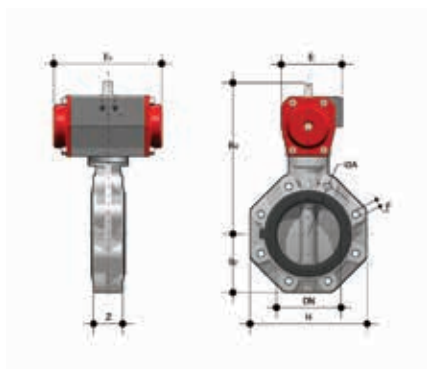

FKOV/CP DA LUG ISO-DIN DN 80-200

LUG ISO-DIN version butterfly valve with pneumatic actuator Double-Acting function

d	DN	PN	B ₂	H	Z	ΦA	f	U	B ₄	E	E ₁	g	EPDM Code	FKM Code
90	80	10	93	185	49	160	M16	12	253	94	210	5100	FKOLVDA090E	FKOLVDA090F
110	100	10	107	211	56	180	M16	8	110	104	228	6750	FKOLVDA110E	FKOLVDA110F
*125/140	125	10	120	240	64	210	M16	8	297	104	228	8350	FKOLVDA140E	FKOLVDA140F
160	150	10	134	268	70	240	M20	8	325	120	280	10700	FKOLVDA160E	FKOLVDA160F
**200/225	200	10	161	323	71	295	M20	8	399	134	310	16800	FKOLVDA225E	FKOLVDA225F

* FKOV d140 with special adapter collars d125
 ** FKOV d225 with special adapter collars d200

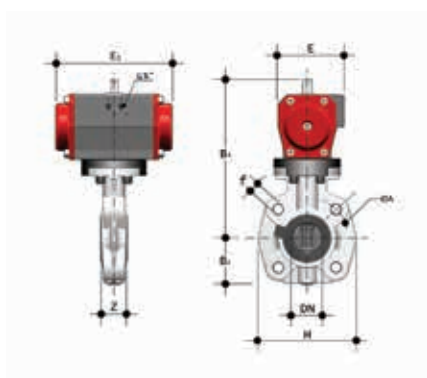

FKOV/CP NC LUG ISO-DIN DN 65

LUG ISO-DIN version butterfly valve with pneumatic actuator, Normally closed function

d	DN	PN	B ₂	H	Z	ΦA	f	U	B ₄	E	E ₁	g	EPDM Code	FKM Code
75	65	10	80	165	46	145	M16	4	239	94	210	4800	FKOLVNC075E	FKOLVNC075F

DIMENSIONS

FK/CP DN 40÷400 PVC-U

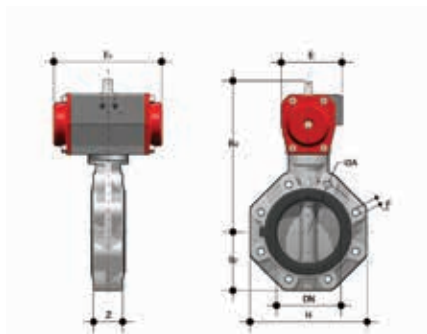

FKOV/CP NC LUG ISO-DIN DN 80-200

LUG ISO-DIN version butterfly valve with pneumatic actuator, Normally closed function

d	DN	PN	B ₂	H	Z	ΦA	f	U	B ₄	E	E ₁	g	EPDM Code	FKM Code
90	80	10	93	185	49	160	M16	12	263	104	228	7000	FKOLVNC090E	FKOLVNC090F
110	100	10	107	211	56	180	M16	8	292	120	280	9350	FKOLVNC110E	FKOLVNC110F
*125/140	125	10	120	240	64	210	M16	8	339	134	310	14450	FKOLVNC140E	FKOLVNC140F
160	150	10	134	268	70	240	M20	8	352	134	310	15200	FKOLVNC160E	FKOLVNC160F
*200/225	200	10	161	323	71	295	M20	8	473	176	462	36900	FKOLVNC225E	FKOLVNC225F

* FKOV d140 with special adapter collars d125
 ** FKOV d225 with special adapter collars d200

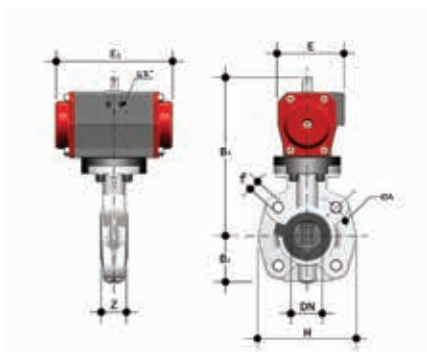

FKOV/CP NO LUG ISO-DIN DN 65

LUG ISO-DIN version butterfly valve with pneumatic actuator Normally Open function

d	DN	PN	B ₂	H	Z	ΦA	f	U	B ₄	E	E ₁	g	EPDM Code	FKM Code
75	65	10	80	165	46	145	M16	4	239	94	210	4800	FKOLVNO075E	FKOLVNO075F

DIMENSIONS

FK/CP DN 40÷400 PVC-U

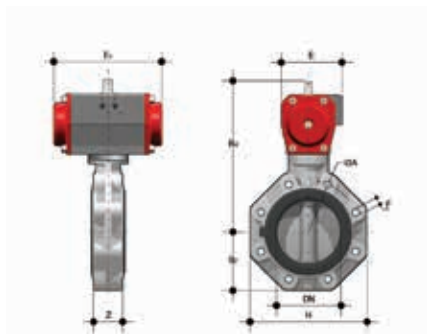

FKOV/CP NO LUG ISO-DIN DN 80-200

LUG ISO-DIN version butterfly valve with pneumatic actuator Normally Open function

d	DN	PN	B ₂	H	Z	ΦA	f	U	B ₄	E	E ₁	g	EPDM Code	FKM Code
90	80	10	93	185	49	160	M16	12	263	104	228	7000	FKOLVNO090E	FKOLVNO090F
110	100	10	107	211	56	180	M16	8	292	120	280	9350	FKOLVNO110E	FKOLVNO110F
*125/140	125	10	120	240	64	210	M16	8	339	134	310	14450	FKOLVNO140E	FKOLVNO140F
160	150	10	134	268	70	240	M20	8	352	134	310	15200	FKOLVNO160E	FKOLVNO160F
**200/225	200	10	161	323	71	295	M20	8	473	176	462	36900	FKOLVNO225E	FKOLVNO225F

* FKOV d140 with special adapter collars d125
 ** FKOV d225 with special adapter collars d200

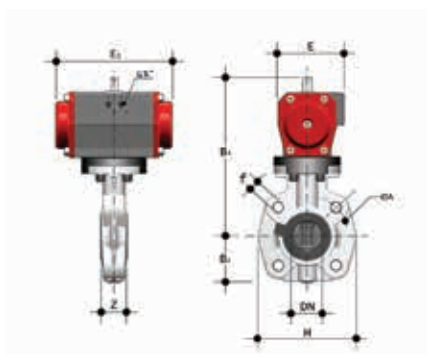

FKOV/CP DA LUG ANSI DN 65

LUG ANSI 150 version butterfly valve with pneumatic actuator Double-Acting function

d	DN	PN	B ₂	H	Z	ΦA	f	U	B ₄	E	E ₁	g	EPDM Code	FKM Code
2"1/2	65	10	80	165	46	139.7	5/8"	4	222	86	155	3000	FKOALVDA212E	FKOALVDA212F

DIMENSIONS

FK/CP DN 40÷400 PVC-U

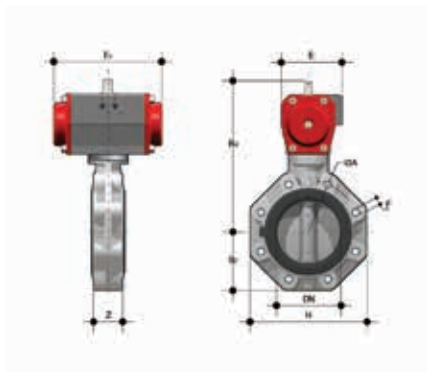

FKOV/CP DA LUG ANSI DN 80-200

LUG ANSI 150 version butterfly valve with pneumatic actuator Double-Acting function

d	DN	PN	B ₂	H	Z	ΦA	f	U	B ₄	E	E ₁	g	EPDM Code	FKM Code
3"	80	10	93	185	49	152.4	5/8"	12	253	94	210	5100	FKOALVDA300E	FKOALVDA300F
4"	100	10	107	211	56	190.5	5/8"	8	110	104	228	6750	FKOALVDA400E	FKOALVDA400F
5"	125	10	120	240	64	215.9	3/4"	8	297	104	228	8350	FKOALVDA500E	FKOALVDA500F
6"	150	10	134	268	70	241.3	3/4"	8	325	120	280	10700	FKOALVDA600E	FKOALVDA600F
8"	200	10	161	323	71	298.4	3/4"	8	399	134	310	16800	FKOALVDA800E	FKOALVDA800F

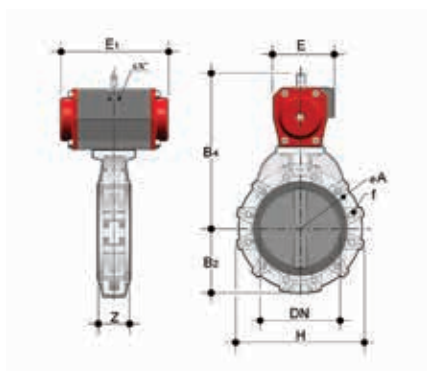

FKOV/CP DA LUG ANSI DN 250-300

LUG ANSI 150 version butterfly valve with pneumatic actuator Double-Acting function

d	DN	PN	B ₂	H	Z	ΦA	f	U	B ₄	E	E ₁	g	EPDM Code	FKM Code
10"	250	6	210	405	114	362	7/8"	12	453	163	390	32300	FKOALVDA810E	FKOALVDA810F
12"	300	6	245	475	114	431.8	7/8"	12	453	163	390	39300	FKOALVDA812E	FKOALVDA812F

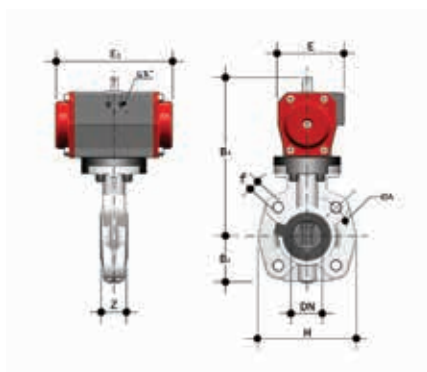

FKOV/CP NC LUG ANSI DN 65

LUG ANSI 150 version butterfly valve with pneumatic actuator, Normally closed function

d	DN	PN	B ₂	H	Z	ΦA	f	U	B ₄	E	E ₁	g	EPDM Code	FKM Code
2 1/2"	65	10	80	165	46	139.7	5/8"	4	239	94	210	4800	FKOALVNC212E	FKOALVNC212F

DIMENSIONS

FK/CP DN 40÷400 PVC-U

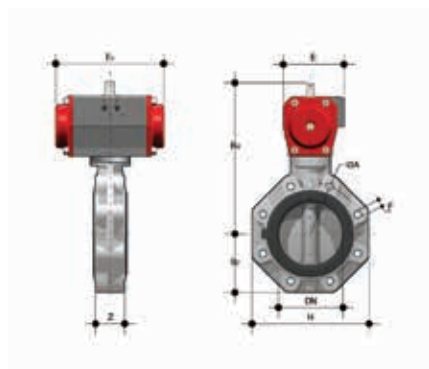

FKOV/CP NC LUG ANSI DN 80-200

LUG ANSI 150 version butterfly valve with pneumatic actuator, Normally closed function

d	DN	PN	B ₂	H	Z	ΦA	f	U	B ₄	E	E ₁	g	EPDM Code	FKM Code
3"	80	10	93	185	49	152.4	5/8"	12	263	104	228	7000	FKOALVNC300E	FKOALVNC300F
4"	100	10	107	211	56	190.5	5/8"	8	292	120	280	9350	FKOALVNC400E	FKOALVNC400F
5"	125	10	120	240	64	215.9	3/4"	8	339	134	310	14450	FKOALVNC500E	FKOALVNC500F
6"	150	10	134	268	70	241.3	3/4"	8	352	134	310	15200	FKOALVNC600E	FKOALVNC600F
8"	200	10	161	323	71	298.4	3/4"	8	473	176	462	36900	FKOALVNC800E	FKOALVNC800F

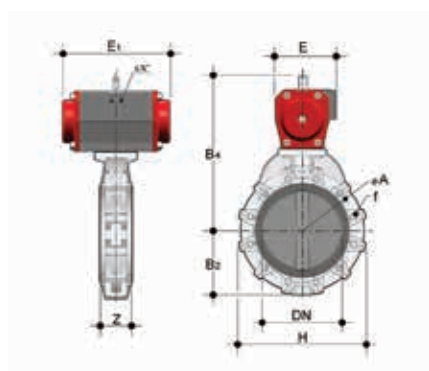

FKOV/CP NC LUG ANSI DN 250-300

LUG ANSI 150 version butterfly valve with pneumatic actuator, Normally closed function

d	DN	PN	B ₂	H	Z	ΦA	f	U	B ₄	E	E ₁	g	EPDM Code	FKM Code
10"	250	6	210	405	114	362	7/8"	12	538	220	575	69800	FKOALVNC810E	FKOALVNC810F
12"	300	6	245	475	114	431.8	7/8"	12	538	220	575	76800	FKOALVNC812E	FKOALVNC812F

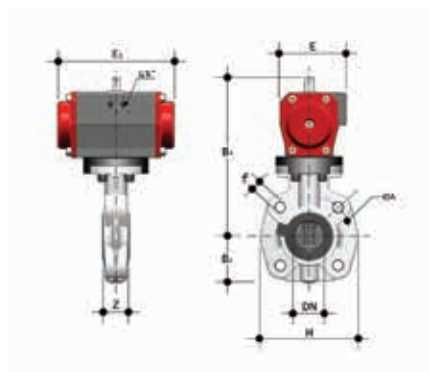

FKOV/CP NO LUG ANSI DN 65

LUG ANSI 150 version butterfly valve with pneumatic actuator, Normally open function

d	DN	PN	B ₂	H	Z	ΦA	f	U	B ₄	E	E ₁	g	EPDM Code	FKM Code
2 1/2"	65	10	80	165	46	139.7	5/8"	4	239	94	210	4800	FKOALVNO212E	FKOALVNO212F

DIMENSIONS

FK/CP DN 40÷400 PVC-U

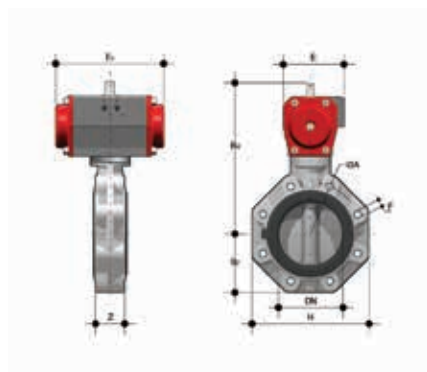

FKOV/CP NO LUG ANSI DN 80-200

LUG ANSI 150 version butterfly valve with pneumatic actuator, Normally open function

d	DN	PN	B ₂	H	Z	ΦA	f	U	B ₄	E	E ₁	g	EPDM Code	FKM Code
3"	80	10	93	185	49	152.4	5/8"	12	263	104	228	7000	FKOALVNO300E	FKOALVNO300F
4"	100	10	107	211	56	190.5	5/8"	8	292	120	280	9350	FKOALVNO400E	FKOALVNO400F
5"	125	10	120	240	64	215.9	3/4"	8	339	134	310	14450	FKOALVNO500E	FKOALVNO500F
6"	150	10	134	268	70	241.3	3/4"	8	352	134	310	15200	FKOALVNO600E	FKOALVNO600F
8"	200	10	161	323	71	298.4	3/4"	8	473	176	462	36900	FKOALVNO800E	FKOALVNO800F

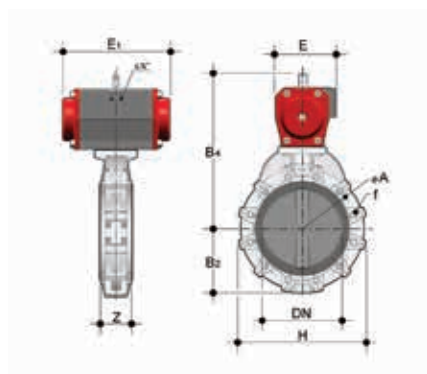

FKOV/CP NO LUG ANSI DN 250-300

LUG ANSI 150 version butterfly valve with pneumatic actuator, Normally open function

d	DN	PN	B ₂	H	Z	ΦA	f	U	B ₄	E	E ₁	g	EPDM Code	FKM Code
10"	250	6	210	405	114	362	7/8"	12	538	220	575	69800	FKOALVNO810E	FKOALVNO810F
12"	300	6	245	475	114	431.8	7/8"	12	538	220	575	76800	FKOALVNO812E	FKOALVNO812F

DIMENSIONS

FK/CP DN 40÷300 PVC-C

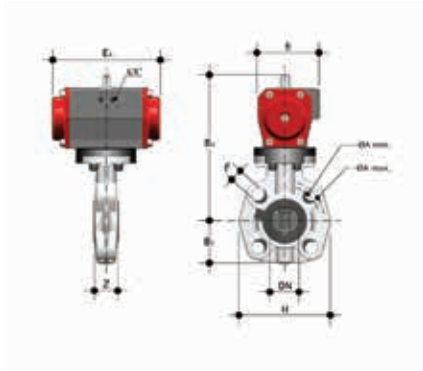

FKOC/CP DA DN 40-65

Butterfly valve with pneumatic actuator, Double-Acting function

d	DN	PN	B ₂	H	Z	A _{min}	A _{max}	f	U	B ₄	E	E ₁	g	EPDM Code	FKM Code
50-1 1/2"	40	16	60	132	33	99	109	19	4	209	86	155	2224	FKOCDA050E	FKOCDA050F
63-2"	50	16	70	147	43	115	125.5	19	4	215	86	155	2420	FKOCDA063E	FKOCDA063F
75-2 1/2"	65	10	80	165	46	128	144	19	4	222	86	155	2687	FKOCDA075E	FKOCDA075F

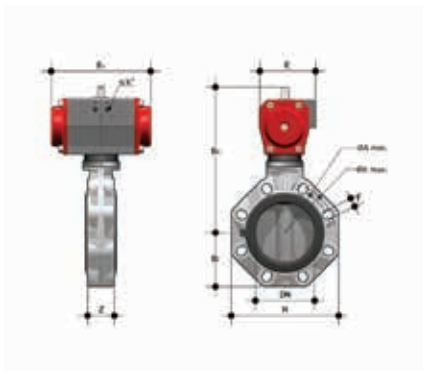

FKOC/CP DA DN 80-200

Butterfly valve with pneumatic actuator, Double-Acting function

d	DN	PN	B ₂	H	Z	A _{min}	A _{max}	f	U	B ₄	E	E ₁	g	EPDM Code	FKM Code
90-3"	80	10	93	185	49	145	160	19	12	253	94	210	4422	FKOCDA090E	FKOCDA090F
110-4"	100	10	107	211	56	165	190	19	8	110	104	228	6102	FKOCDA110E	FKOCDA110F
140-5"	125	10	120	240	64	204	215	23	8	297	104	228	6972	FKOCDA140E	FKOCDA140F
160-6"	150	10	134	268	70	230	242	23	8	325	120	280	9387	FKOCDA160E	FKOCDA160F
225-8"	200	10	161	323	71	280	298	23	8	399	134	310	15722	FKOCDA225E	FKOCDA225F

DIMENSIONS

FK/CP DN 40÷300 PVC-C

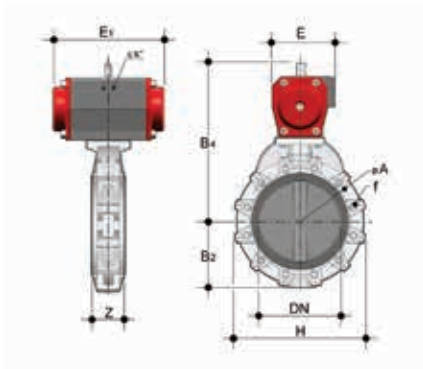

FKOC/CP DA DN 250-300

Butterfly valve with pneumatic actuator, Double-Acting function

d	DN	PN	B ₁	H	Z	ΦA	f	U	B ₄	E	E ₁	g	EPDM Code	FKM Code
250/280	*250	10	210	405	114	350	22	12	453	163	390	28543	FKOCDA280E	FKOCDA280F
315	*300	8	245	475	114	400	22	12	510	163	390	36152	FKOCDA315E	FKOCDA315F
10"	**250	10	210	405	114	362	25.4	12	453	163	390	28543	FKOACDA810E	FKOACDA810F
12"	**300	8	245	475	114	432	25.4	12	510	163	390	36152	FKOACDA812E	FKOACDA812F

*ISO-DIN
**ANSI B.16.5 150

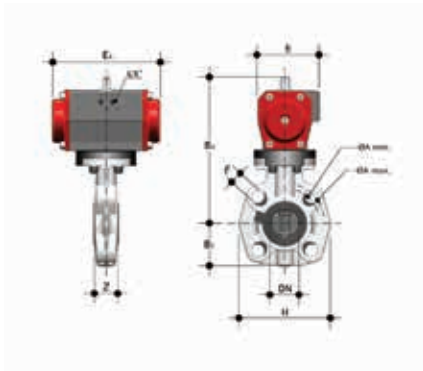

FKOC/CP NC DN 40-65

Butterfly valve with pneumatic actuator, Normally Closed function

d	DN	PN	B ₂	H	Z	A _{min}	A _{max}	f	U	B ₄	E	E ₁	g	EPDM Code	FKM Code
50-1 1/2"	40	16	60	132	33	99	109	19	4	209	86	155	2420	FKOCNC050E	FKOCNC050F
63-2"	50	16	70	147	43	115	125.5	19	4	232	94	210	4186	FKOCNC063E	FKOCNC063F
75-2 1/2"	65	10	80	165	46	128	144	19	4	239	94	210	4487	FKOCNC075E	FKOCNC075F

DIMENSIONS

FK/CP DN 40÷300 PVC-C

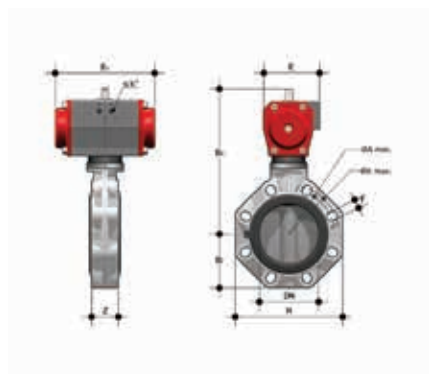

FKOC/CP NC DN 80-200

Butterfly valve with pneumatic actuator, Normally Closed function

d	DN	PN	B ₂	H	Z	A _{min}	A _{max}	f	U	B ₄	E	E ₁	g	EPDM Code	FKM Code
90-3"	80	10	93	185	49	145	160	19	12	263	104	228	6322	FKOCNC090E	FKOCNC090F
110-4"	100	10	107	211	56	165	190	19	8	292	120	280	8702	FKOCNC110E	FKOCNC110F
125/140-5"	125	10	120	240	64	204	215	23	8	339	134	310	13072	FKOCNC140E	FKOCNC140F
160-6"	150	10	134	268	70	230	242	23	8	352	134	310	13887	FKOCNC160E	FKOCNC160F
200/225-8"	200	10	161	323	71	280	298	23	8	473	176	462	35822	FKOCNC225E	FKOCNC225F

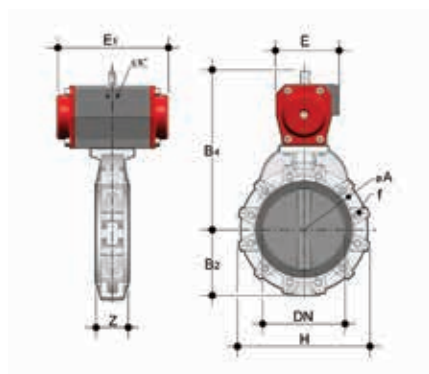

FKOC/CP NC DN 250-300

Butterfly valve with pneumatic actuator, Normally Closed function

d	DN	PN	B ₂	H	Z	ΦA	f	U	B ₄	E	E ₁	g	EPDM Code	FKM Code
250/280	*250	10	210	405	114	350	22	12	538	220	575	66043	FKOCNC280E	FKOCNC280F
315	*300	8	245	475	114	400	22	12	595	220	575	73652	FKOCNC315E	FKOCNC315F
10"	**250	10	210	405	114	362	25.4	12	538	220	575	66043	FKOACNC810E	FKOACNC810F
12"	**300	8	245	475	114	432	25.4	12	595	220	575	73652	FKOACNC812E	FKOACNC812F

*ISO-DIN
**ANSI B.16.5 150

DIMENSIONS

FK/CP DN 40÷300 PVC-C

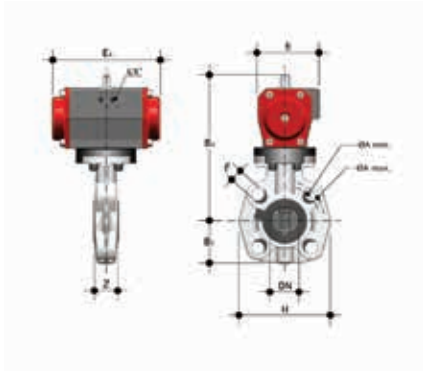

FKOC/CP NO DN 40-65

Butterfly valve with pneumatic actuator, Normally Open function

d	DN	PN	B ₂	H	Z	A _{min}	A _{max}	f	U	B ₄	E	E ₁	g	EPDM Code	FKM Code
50-1 1/2"	40	16	60	132	33	99	109	19	4	209	86	155	2420	FKOCNO050E	FKOCNO050F
63-2"	50	16	70	147	43	115	125.5	19	4	232	94	210	4186	FKOCNO063E	FKOCNO063F
75-2 1/2"	65	10	80	165	46	128	144	19	4	239	94	210	4487	FKOCNO075E	FKOCNO075F

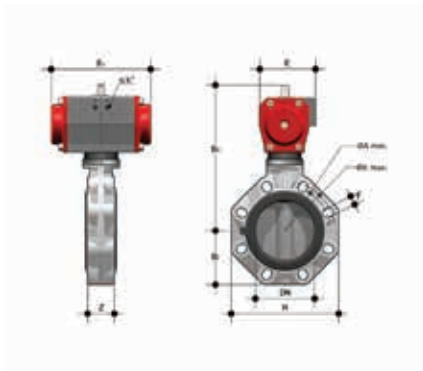

FKOC/CP NO DN 80-200

Butterfly valve with pneumatic actuator, Normally Open function

d	DN	PN	B ₂	H	Z	A _{min}	A _{max}	f	U	B ₄	E	E ₁	g	EPDM Code	FKM Code
90-3"	80	10	93	185	49	145	160	19	12	263	104	228	6322	FKOCNO090E	FKOCNO090F
110-4"	100	10	107	211	56	165	190	19	8	292	120	280	8702	FKOCNO110E	FKOCNO110F
125/140-5"	125	10	120	240	64	204	215	23	8	339	134	310	13072	FKOCNO140E	FKOCNO140F
160-6"	150	10	134	268	70	230	242	23	8	352	134	310	13887	FKOCNO160E	FKOCNO160F
200/225-8"	200	10	161	323	71	280	298	23	8	473	176	462	35822	FKOCNO225E	FKOCNO225F

DIMENSIONS

FK/CP DN 40÷300 PVC-C

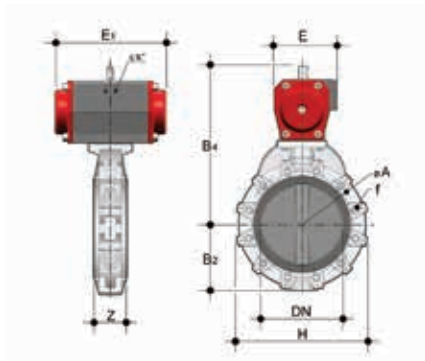

FKOC/CP NO DN 250-300

Butterfly valve with pneumatic actuator, Normally Open function

d	DN	PN	B ₂	H	Z	ΦA	f	U	B ₄	E	E ₁	g	EPDM Code	FKM Code
250/280	*250	10	210	405	114	350	22	12	538	220	575	66043	FKOCNO280E	FKOCNO280F
315	*300	8	245	475	114	400	22	12	595	220	575	73652	FKOCNO315E	FKOCNO315F
10"	**250	10	210	405	114	362	25.4	12	538	220	575	66043	FKOACNO810E	FKOACNO810F
12"	**300	8	245	475	114	432	25.4	12	595	220	575	73652	FKOACNO812E	FKOACNO812F

*ISO-DIN
**ANSI B.16.5 150

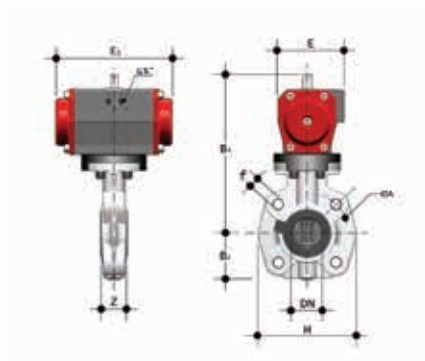

FKOC/CP DA LUG ISO-DIN DN 65

LUG ISO-DIN version butterfly valve with pneumatic actuator Double-Acting function

d	DN	PN	B ₂	H	Z	ΦA	f	U	B ₄	E	E ₁	g	EPDM Code	FKM Code
75	65	10	80	165	46	145	M16	4	222	86	155	3122	FKOLCDA075E	FKOLCDA075F

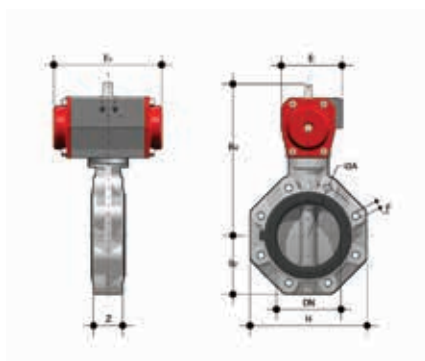

FKOC/CP DA LUG ISO-DIN DN 80-200

LUG ISO-DIN version butterfly valve with pneumatic actuator Double-Acting function

d	DN	PN	B ₂	H	Z	ΦA	f	U	B ₄	E	E ₁	g	EPDM Code	FKM Code
90	80	10	93	185	49	160	M16	12	253	94	210	5291	FKOLCDA090E	FKOLCDA090F
110	100	10	107	211	56	180	M16	8	110	104	228	6972	FKOLCDA110E	FKOLCDA110F
125/140	125	10	120	240	64	210	M16	8	297	104	228	8711	FKOLCDA140E	FKOLCDA140F
160	150	10	134	268	70	240	M20	8	325	120	280	11126	FKOLCDA160E	FKOLCDA160F
200/225	200	10	161	323	71	295	M20	8	399	134	310	17461	FKOLCDA225E	FKOLCDA225F

DIMENSIONS

FK/CP DN 40÷300 PVC-C

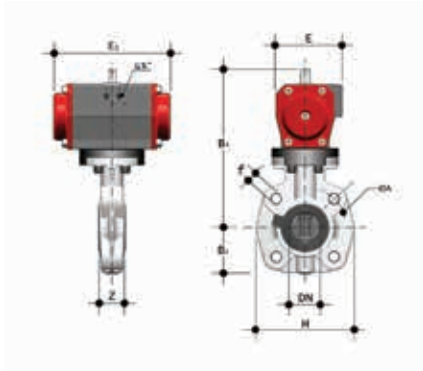

FKOC/CP NC LUG ISO-DIN DN 65

LUG ISO-DIN version butterfly valve with pneumatic actuator, Normally closed function

d	DN	PN	B ₂	H	Z	ΦA	f	U	B ₄	E	E ₁	g	EPDM Code	FKM Code
75	65	10	80	165	46	145	M16	4	239	94	210	4922	FKOLCNC075E	FKOLCNC075F

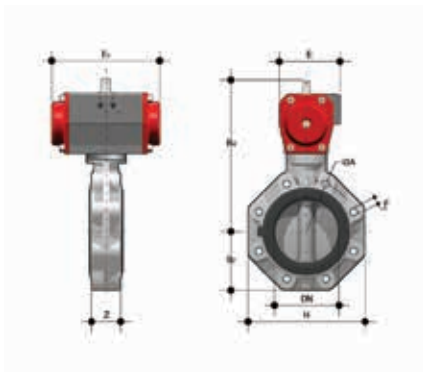

FKOC/CP NC LUG ISO-DIN DN 80-200

LUG ISO-DIN version butterfly valve with pneumatic actuator, Normally closed function

d	DN	PN	B ₂	H	Z	ΦA	f	U	B ₄	E	E ₁	g	EPDM Code	FKM Code
90	80	10	93	185	49	160	M16	12	263	104	228	7191	FKOLCNC090E	FKOLCNC090F
110	100	10	107	211	56	180	M16	8	292	120	280	9572	FKOLCNC110E	FKOLCNC110F
125/140	125	10	120	240	64	210	M16	8	339	134	310	14811	FKOLCNC140E	FKOLCNC140F
160	150	10	134	268	70	240	M20	8	352	134	310	15626	FKOLCNC160E	FKOLCNC160F
200/225	200	10	161	323	71	295	M20	8	473	176	462	37561	FKOLCNC225E	FKOLCNC225F

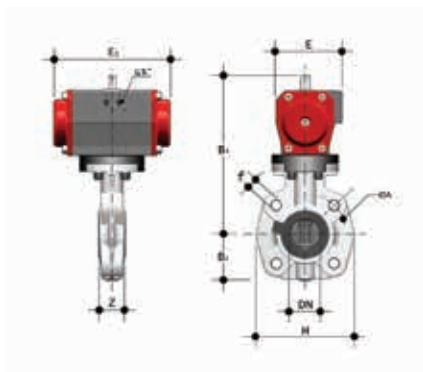

FKOC/CP NO LUG ISO-DIN DN 65

LUG ISO-DIN version butterfly valve with pneumatic actuator, Normally open function

d	DN	PN	B ₂	H	Z	ΦA	f	U	B ₄	E	E ₁	g	EPDM Code	FKM Code
75	65	10	80	165	46	145	M16	4	239	94	210	4922	FKOLCNO075E	FKOLCNO075F

DIMENSIONS

FK/CP DN 40÷300 PVC-C

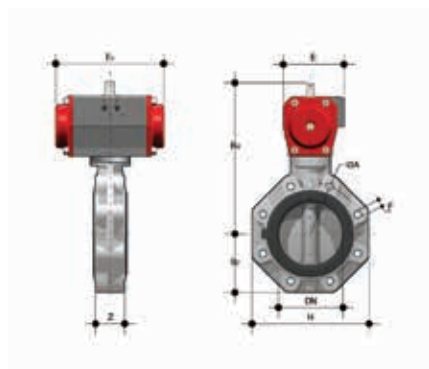

FKOC/CP NO LUG ISO-DIN DN 80-200

LUG ISO-DIN version butterfly valve with pneumatic actuator, Normally open function

d	DN	PN	B ₂	H	Z	ΦA	f	U	B ₄	E	E ₁	g	EPDM Code	FKM Code
90	80	10	93	185	49	160	M16	12	263	104	228	7191	FKOLCNO090E	FKOLCNO090F
110	100	10	107	211	56	180	M16	8	292	120	280	9572	FKOLCNO110E	FKOLCNO110F
125/140	125	10	120	240	64	210	M16	8	339	134	310	14811	FKOLCNO140E	FKOLCNO140F
160	150	10	134	268	70	240	M20	8	352	134	310	15626	FKOLCNO160E	FKOLCNO160F
200/225	200	10	161	323	71	295	M20	8	473	176	462	37561	FKOLCNO225E	FKOLCNO225F

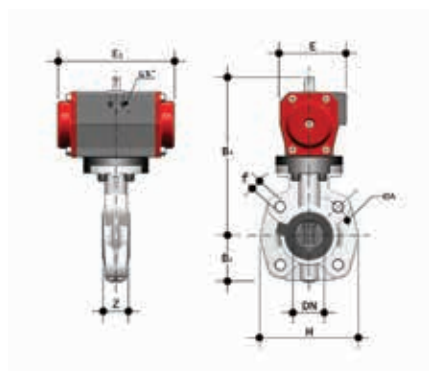

FKOC/CP DA LUG ANSI DN 65

LUG ANSI 150 version butterfly valve with pneumatic actuator Double-Acting function

d	DN	PN	B ₂	H	Z	ΦA	f	U	B ₄	E	E ₁	g	EPDM Code	FKM Code
2 1/2"	65	10	80	165	46	139.7	5/8"	4	222	86	155	3122	FKOALCDA212E	FKOALCDA212F

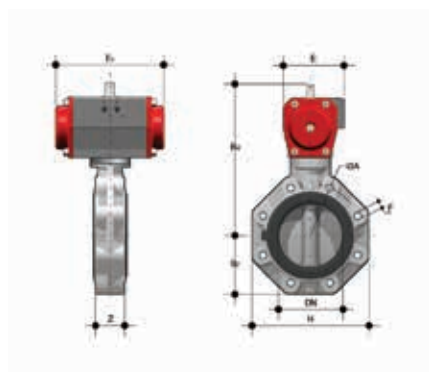

FKOC/CP DA LUG ANSI DN 80-200

LUG ANSI 150 version butterfly valve with pneumatic actuator Double-Acting function

d	DN	PN	B ₂	H	Z	ΦA	f	U	B ₄	E	E ₁	g	EPDM Code	FKM Code
3"	80	10	93	185	49	152.4	5/8"	12	253	94	210	5291	FKOALCDA300E	FKOALCDA300F
4"	100	10	107	211	56	190.5	5/8"	8	110	104	228	6972	FKOALCDA400E	FKOALCDA400F
5"	125	10	120	240	64	215.9	3/4"	8	297	104	228	8711	FKOALCDA500E	FKOALCDA500F
6"	150	10	134	268	70	241.3	3/4"	8	325	120	280	11126	FKOALCDA600E	FKOALCDA600F
8"	200	10	161	323	71	298.4	3/4"	8	399	134	310	17461	FKOALCDA800E	FKOALCDA800F

DIMENSIONS

FK/CP DN 40÷300 PVC-C

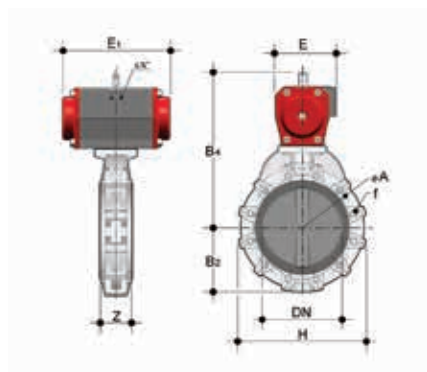

FKOC/CP DA LUG ANSI DN 250-300

LUG ANSI 150 version butterfly valve with pneumatic actuator Double-Acting function

d	DN	PN	B ₂	H	Z	ΦA	f	U	B ₄	E	E ₁	g	EPDM Code	FKM Code
10"	250	6	210	405	114	362	7/8"	12	453	163	390	33761	FKOALCDA810E	FKOALCDA810F
12"	300	6	245	475	114	431.8	7/8"	12	453	163	390	41370	FKOALCDA812E	FKOALCDA812F

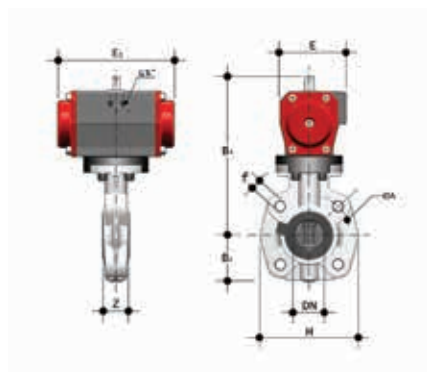

FKOC/CP NC LUG ANSI DN 65

LUG ANSI 150 version butterfly valve with pneumatic actuator Normally Closed function

d	DN	PN	B ₂	H	Z	ΦA	f	U	B ₄	E	E ₁	g	EPDM Code	FKM Code
2 1/2"	65	10	80	165	46	139.7	5/8"	4	239	94	210	4922	FKOALCNC212E	FKOALCNC212F

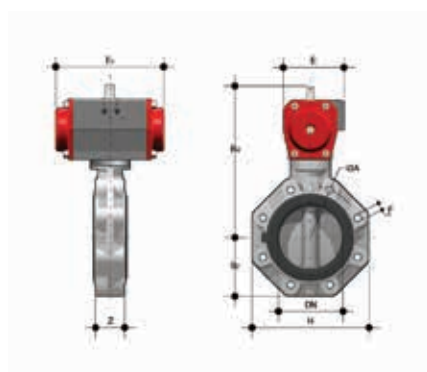

FKOC/CP NC LUG ANSI DN 80-200

LUG ANSI 150 version butterfly valve with pneumatic actuator Normally Closed function

d	DN	PN	B ₂	H	Z	ΦA	f	U	B ₄	E	E ₁	g	EPDM Code	FKM Code
3"	80	10	93	185	49	152.4	5/8"	12	263	104	228	7191	FKOALCNC300E	FKOALCNC300F
4"	100	10	107	211	56	190.5	5/8"	8	292	120	280	9572	FKOALCNC400E	FKOALCNC400F
5"	125	10	120	240	64	215.9	3/4"	8	339	134	310	14811	FKOALCNC500E	FKOALCNC500F
6"	150	10	134	268	70	241.3	3/4"	8	352	134	310	15626	FKOALCNC600E	FKOALCNC600F
8"	200	10	161	323	71	298.4	3/4"	8	473	176	462	37561	FKOALCNC800E	FKOALCNC800F

DIMENSIONS

FK/CP DN 40÷300 PVC-C

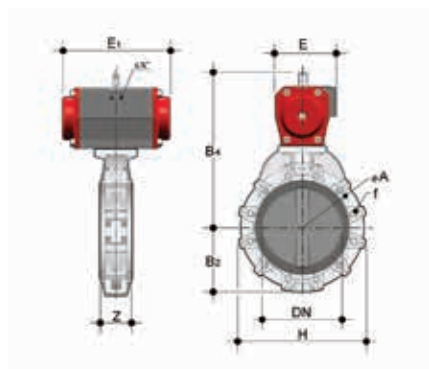

FKOC/CP NC LUG ANSI DN 250-300

LUG ANSI 150 version butterfly valve with pneumatic actuator Normally Closed function

d	DN	PN	B ₂	H	Z	ΦA	f	U	B ₄	E	E ₁	g	EPDM Code	FKM Code
10"	250	6	210	405	114	362	7/8"	12	538	220	575	71261	FKOALCNC810E	FKOALCNC810F
12"	300	6	245	475	114	431.8	7/8"	12	538	220	575	78870	FKOALCNC812E	FKOALCNC812F

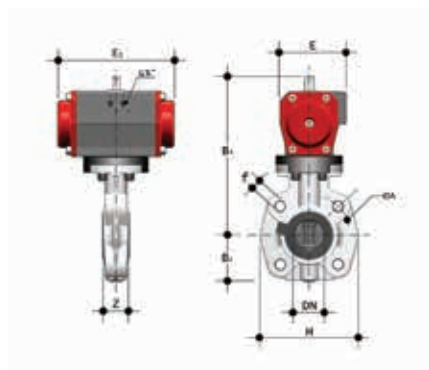

FKOC/CP NO LUG ANSI DN 65

LUG ANSI 150 version butterfly valve with pneumatic actuator Normally Open function

d	DN	PN	B ₂	H	Z	ΦA	f	U	B ₄	E	E ₁	g	EPDM Code	FKM Code
2 1/2"	65	10	80	165	46	139.7	5/8"	4	239	94	210	4922	FKOALCNO212E	FKOALCNO212F

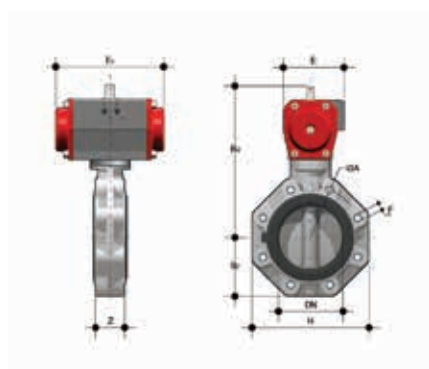

FKOC/CP NO LUG ANSI DN 80-200

LUG ANSI 150 version butterfly valve with pneumatic actuator Normally Open function

d	DN	PN	B ₂	H	Z	ΦA	f	U	B ₄	E	E ₁	g	EPDM Code	FKM Code
3"	80	10	93	185	49	152.4	5/8"	12	263	104	228	7191	FKOALCNO300E	FKOALCNO300F
4"	100	10	107	211	56	190.5	5/8"	8	292	120	280	9572	FKOALCNO400E	FKOALCNO400F
5"	125	10	120	240	64	215.9	3/4"	8	339	134	310	14811	FKOALCNO500E	FKOALCNO500F
6"	150	10	134	268	70	241.3	3/4"	8	352	134	310	15626	FKOALCNO600E	FKOALCNO600F
8"	200	10	161	323	71	298.4	3/4"	8	473	176	462	37561	FKOALCNO800E	FKOALCNO800F

DIMENSIONS

FK/CP DN 40÷300 PVC-C

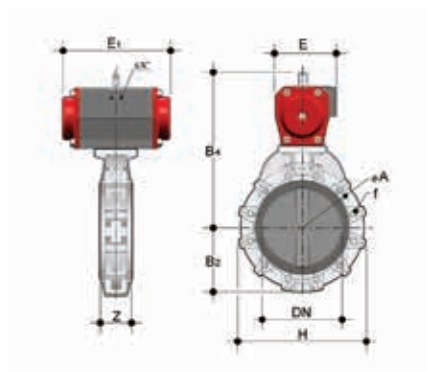

FKOC/CP NO LUG ANSI DN 250-300

LUG ANSI 150 version butterfly valve with pneumatic actuator Normally Open function

d	DN	PN	B ₂	H	Z	ΦA	f	U	B ₄	E	E ₁	g	EPDM Code	FKM Code
10"	250	6	210	405	114	362	7/8"	12	538	220	575	71261	FKOALCNO810E	FKOALCNO810F
12"	300	6	245	475	114	431.8	7/8"	12	538	220	575	78870	FKOALCNO812E	FKOALCNO812F

DIMENSIONS

FK/CP DN 40÷400 PP-H

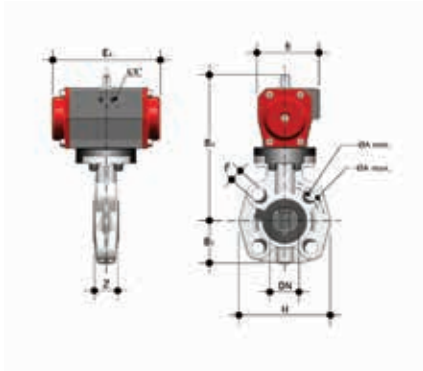

FKOM/CP DA DN 40-65

Butterfly valve with pneumatic actuator, Double-Acting function

d	DN	PN	B ₂	H	Z	A _{min}	A _{max}	f	U	B ₄	E	E ₁	g	EPDM Code	FKM Code
50-1 1/2"	40	10	60	132	33	99	109	19	4	209	86	155	2074	FKOMDA050E	FKOMDA050F
63-2"	50	10	70	147	43	115	125.5	19	4	215	86	155	2254	FKOMDA063E	FKOMDA063F
75-2 1/2"	65	10	80	165	46	128	144	19	4	222	86	155	2500	FKOMDA075E	FKOMDA075F

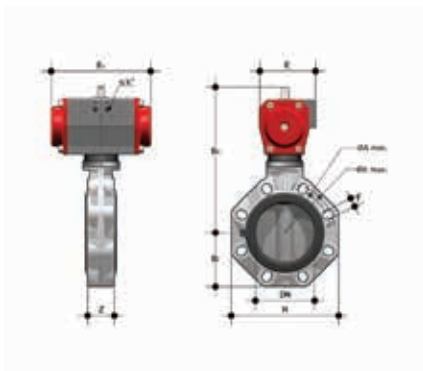

FKOM/CP DA DN 80-200

Butterfly valve with pneumatic actuator, Double-Acting function

d	DN	PN	B ₂	H	Z	A _{min}	A _{max}	f	U	B ₄	E	E ₁	g	EPDM Code	FKM Code
90-3"	80	10	93	185	49	145	160	19	12	253	94	210	4200	FKOMDA090E	FKOMDA090F
110-4"	100	10	107	211	56	165	190	19	8	110	104	228	5850	FKOMDA110E	FKOMDA110F
140-5"	125	10	120	240	64	204	215	23	8	297	104	228	6650	FKOMDA140E	FKOMDA140F
160-6"	150	10	134	268	70	230	242	23	8	325	120	280	9000	FKOMDA160E	FKOMDA160F
225-8"	200	10	161	323	71	280	298	23	8	399	134	310	15100	FKOMDA225E	FKOMDA225F

DIMENSIONS

FK/CP DN 40÷400 PP-H

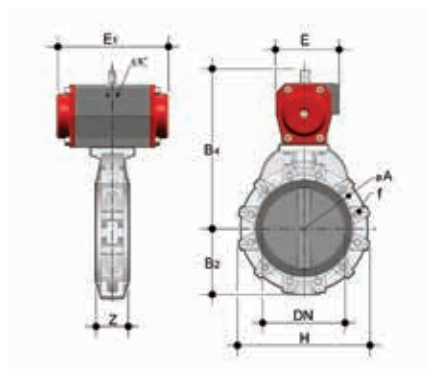

FKOM/CP DA DN 250-300

Butterfly valve with pneumatic actuator, Double-Acting function

d	DN	PN	B ₂	H	Z	ΦA	f	U	B ₄	E	E ₁	g	EPDM Code	FKM Code
250/280	*250	10	210	405	114	350	22	12	453	163	390	27300	FKOMDA280E	FKOMDA280F
315	*300	8	245	475	114	400	22	12	510	163	390	34200	FKOMDA315E	FKOMDA315F
10"	**250	10	210	405	114	362	25.4	12	453	163	390	27300	FKOAMDA810E	FKOAMDA810F
12"	**300	8	245	475	114	432	25.4	12	510	163	390	34200	FKOAMDA812E	FKOAMDA812F

*ISO-DIN
**ANSI B.16.5 150

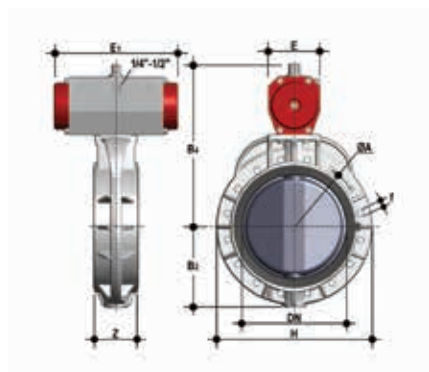

FKOM/CP DA DN 350-400

Butterfly valve with pneumatic actuator, Double-Acting function

d	DN	PN	B ₂	H	Z	ΦA	f	U	B ₄	E	E ₁	g	EPDM Code	FKM Code
355	*350	7	280	530	129	460	22	16	550	196	474	53815	FKOMDA355E	FKOMDA355F
400	*400	6	306	594	169	515	26	16	570	196	474	60810	FKOMDA400E	FKOMDA400F
14"	**350	7	280	530	129	476	28.5	12	550	196	474	53815	FKOAMDA814E	FKOAMDA814F
16"	**400	6	306	594	169	540	28.5	16	570	196	474	60810	FKOAMDA816E	FKOAMDA816F

*ISO-DIN
**ANSI B.16.5 150

DIMENSIONS

FK/CP DN 40÷400 PP-H

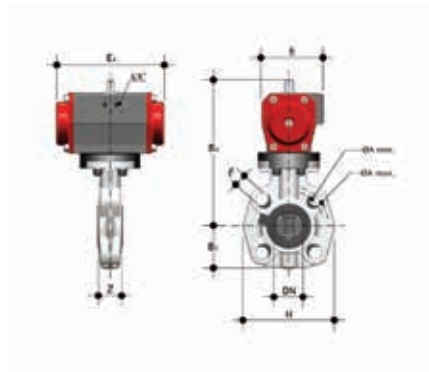

FKOM/CP NC DN 40-65

Butterfly valve with pneumatic actuator, Normally Closed function

d	DN	PN	B ₂	H	Z	A _{min}	A _{max}	f	U	B ₄	E	E ₁	g	EPDM Code	FKM Code
50-1 1/2"	40	10	60	132	33	99	109	19	4	209	86	155	2270	FKOMNC050E	FKOMNC050F
63-2"	50	10	70	147	43	115	125.5	19	4	232	94	210	4020	FKOMNC063E	FKOMNC063F
75-2 1/2"	65	10	80	165	46	128	144	19	4	239	94	210	4300	FKOMNC075E	FKOMNC075F

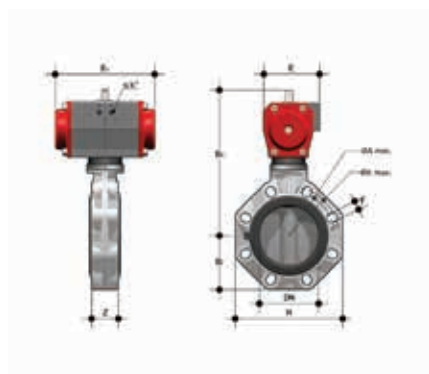

FKOM/CP NC DN 80-200

Butterfly valve with pneumatic actuator, Normally Closed function

d	DN	PN	B ₂	H	Z	A _{min}	A _{max}	f	U	B ₄	E	E ₁	g	EPDM Code	FKM Code
90-3"	80	10	93	185	49	145	160	19	12	263	104	228	6100	FKOMNC090E	FKOMNC090F
110-4"	100	10	107	211	56	165	190	19	8	292	120	280	8450	FKOMNC110E	FKOMNC110F
140-5"	125	10	120	240	64	204	215	23	8	339	134	310	12750	FKOMNC140E	FKOMNC140F
160-6"	150	10	134	268	70	230	242	23	8	352	134	310	13500	FKOMNC160E	FKOMNC160F
225-8"	200	10	161	323	71	280	298	23	8	473	176	462	35200	FKOMNC225E	FKOMNC225F

DIMENSIONS

FK/CP DN 40÷400 PP-H

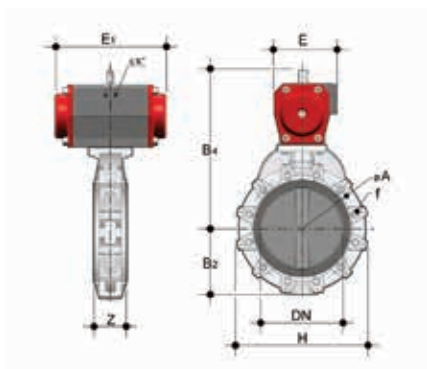

FKOM/CP NC DN 250-300

Butterfly valve with pneumatic actuator, Normally Closed function

d	DN	PN	B ₂	H	Z	ΦA	f	U	B ₄	E	E ₁	g	EPDM Code	FKM Code
250/280	*250	10	210	405	114	350	22	12	538	220	575	64800	FKOMNC280E	FKOMNC280F
315	*300	8	245	475	114	400	22	12	595	220	575	71700	FKOMNC315E	FKOMNC315F
10"	**250	10	210	405	114	362	25.4	12	538	220	575	64800	FKOAMNC810E	FKOAMNC810F
12"	**300	8	245	475	114	432	25.4	12	595	220	575	71700	FKOAMNC812E	FKOAMNC812F

*ISO-DIN
**ANSI B.16.5 150

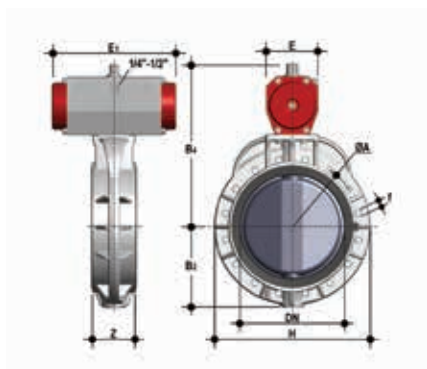

FKOM/CP NC DN 350-400

Butterfly valve with pneumatic actuator, Normally Closed function

d	DN	PN	B ₂	H	Z	ΦA	f	U	B ₄	E	E ₁	g	EPDM Code	FKM Code
355	*350	7	280	530	129	460	22	16	628	300	604	97715	FKOMNC355E	FKOMNC355F
400	*400	6	306	594	169	515	26	16	648	300	604	104710	FKOMNC400E	FKOMNC400F
14"	**350	7	280	530	129	476	28.5	12	628	300	604	97715	FKOAMNC814E	FKOAMNC814F
16"	**400	6	306	594	169	540	28.5	16	648	300	604	104710	FKOAMNC816E	FKOAMNC816F

*ISO-DIN
**ANSI B.16.5 150

DIMENSIONS

FK/CP DN 40÷400 PP-H

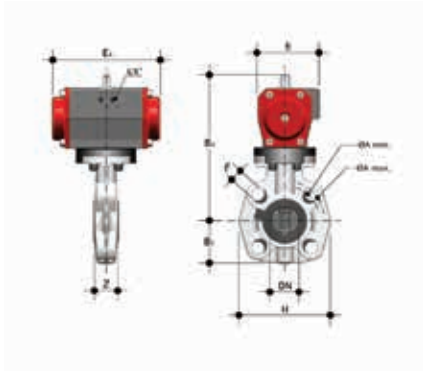

FKOM/CP NO DN 40-65

Butterfly valve with pneumatic actuator, Normally Open function

d	DN	PN	B ₂	H	Z	A _{min}	A _{max}	f	U	B ₄	E	E ₁	g	EPDM Code	FKM Code
50-1 1/2"	40	10	60	132	33	99	109	19	4	209	86	155	2270	FKOMNO050E	FKOMNO050F
63-2"	50	10	70	147	43	115	125.5	19	4	232	94	210	4020	FKOMNO063E	FKOMNO063F
75-2 1/2"	65	10	80	165	46	128	144	19	4	239	94	210	4300	FKOMNO075E	FKOMNO075F

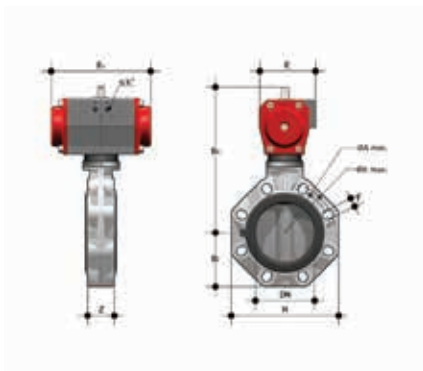

FKOM/CP NO DN 80-200

Butterfly valve with pneumatic actuator, Normally Open function

d	DN	PN	B ₂	H	Z	A _{min}	A _{max}	f	U	B ₄	E	E ₁	g	EPDM Code	FKM Code
90-3"	80	10	93	185	49	145	160	19	12	263	104	228	6100	FKOMNO090E	FKOMNO090F
110-4"	100	10	107	211	56	165	190	19	8	292	120	280	8450	FKOMNO110E	FKOMNO110F
140-5"	125	10	120	240	64	204	215	23	8	339	134	310	12750	FKOMNO140E	FKOMNO140F
160-6"	150	10	134	268	70	230	242	23	8	352	134	310	13500	FKOMNO160E	FKOMNO160F
225-8"	200	10	161	323	71	280	298	23	8	473	176	462	35200	FKOMNO225E	FKOMNO225F

DIMENSIONS

FK/CP DN 40÷400 PP-H

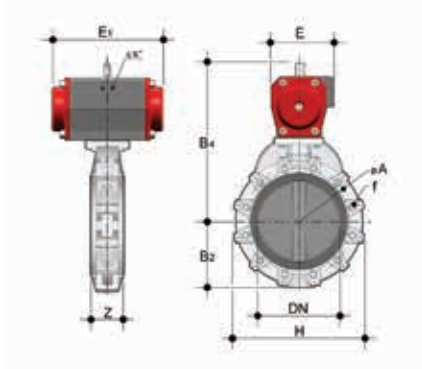

FKOM/CP NO DN 250-300

Butterfly valve with pneumatic actuator, Normally Open function

d	DN	PN	B ₂	H	Z	ΦA	f	U	B ₄	E	E ₁	g	EPDM Code	FKM Code
250/280	*250	10	210	405	114	350	22	12	538	220	575	64800	FKOMNO280E	FKOMNO280F
315	*300	8	245	475	114	400	22	12	595	220	575	71700	FKOMNO315E	FKOMNO315F
10"	**250	10	210	405	114	362	25.4	12	538	220	575	64800	FKOAMNO810E	FKOAMNO810F
12"	**300	8	245	475	114	432	25.4	12	595	220	575	71700	FKOAMNO812E	FKOAMNO812F

*ISO-DIN
**ANSI B.16.5 150

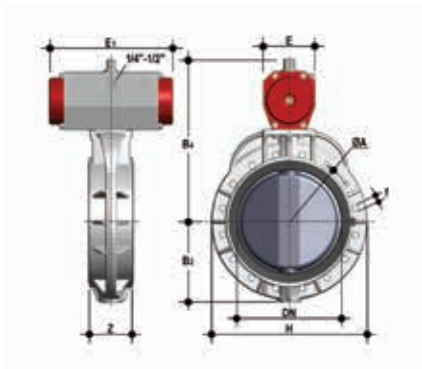

FKOM/CP NO DN 350-400

Butterfly valve with pneumatic actuator, Normally Open function

d	DN	PN	B ₂	H	Z	ΦA	f	U	B ₄	E	E ₁	g	EPDM Code	FKM Code
355	*350	7	280	530	129	460	22	16	628	300	604	95315	FKOMNO355E	FKOMNO355F
400	*400	6	306	594	169	515	26	16	648	300	604	102310	FKOMNO400E	FKOMNO400F
14"	**350	7	280	530	129	476	28.5	12	628	300	604	95315	FKOAMNO814E	FKOAMNO814F
16"	**400	6	306	594	169	540	28.5	16	648	300	604	102310	FKOAMNO816E	FKOAMNO816F

*ISO-DIN
**ANSI B.16.5 150

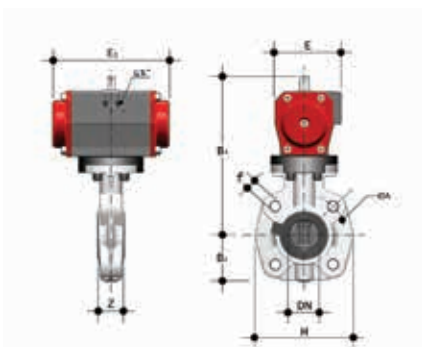

FKOM/CP DA LUG ISO-DIN DN 65

LUG ISO-DIN version butterfly valve with pneumatic actuator Double-Acting function

d	DN	PN	B ₂	H	Z	ΦA	f	U	B ₄	E	E ₁	g	EPDM Code	FKM Code
75	65	10	80	165	46	145	M16	4	222	86	155	2900	FKOLMDA075E	FKOLMDA075F

DIMENSIONS

FK/CP DN 40÷400 PP-H

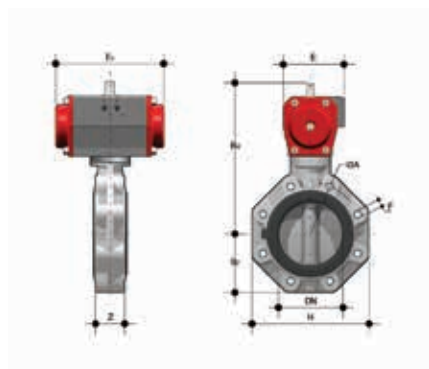

FKOM/CP DA LUG ISO-DIN DN 80-200

LUG ISO-DIN version butterfly valve with pneumatic actuator Double-Acting function

d	DN	PN	B ₂	H	Z	ΦA	f	U	B ₄	E	E ₁	g	EPDM Code	FKM Code
90	80	10	93	185	49	160	M16	12	253	94	210	5000	FKOLMDA090E	FKOLMDA090F
110	100	10	107	211	56	180	M16	8	110	104	228	6650	FKOLMDA110E	FKOLMDA110F
140	125	10	120	240	64	210	M16	8	297	104	228	8250	FKOLMDA140E	FKOLMDA140F
160	150	10	134	268	70	240	M20	8	325	120	280	10600	FKOLMDA160E	FKOLMDA160F
225	200	10	161	323	71	295	M20	8	399	134	310	16700	FKOLMDA225E	FKOLMDA225F

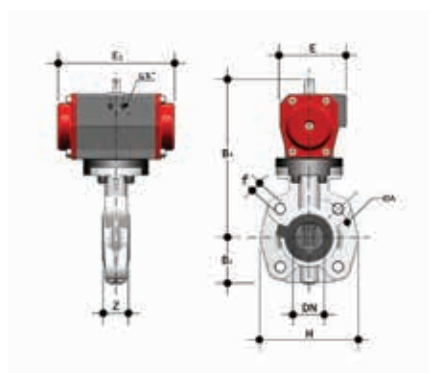

FKOM/CP NC LUG ISO-DIN DN 65

LUG ISO-DIN version butterfly valve with pneumatic actuator Normally Closed function

d	DN	PN	B ₂	H	Z	ΦA	f	U	B ₄	E	E ₁	g	EPDM Code	FKM Code
75	65	10	80	165	46	145	M16	4	239	94	210	4700	FKOLMNC075E	FKOLMNC075F

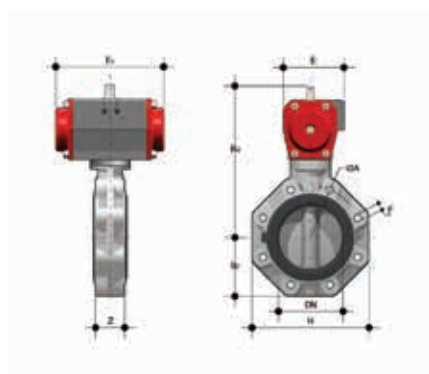

FKOM/CP NC LUG ISO-DIN DN 80-200

LUG ISO-DIN version butterfly valve with pneumatic actuator Normally Closed function

d	DN	PN	B ₂	H	Z	ΦA	f	U	B ₄	E	E ₁	g	EPDM Code	FKM Code
90	80	10	93	185	49	160	M16	12	263	104	228	6900	FKOLMNC090E	FKOLMNC090F
110	100	10	107	211	56	180	M16	8	292	120	280	9250	FKOLMNC110E	FKOLMNC110F
140	125	10	120	240	64	210	M16	8	339	134	310	14350	FKOLMNC140E	FKOLMNC140F
160	150	10	134	268	70	240	M20	8	352	134	310	15100	FKOLMNC160E	FKOLMNC160F
225	200	10	161	323	71	295	M20	8	473	176	462	36800	FKOLMNC225E	FKOLMNC225F

DIMENSIONS

FK/CP DN 40÷400 PP-H

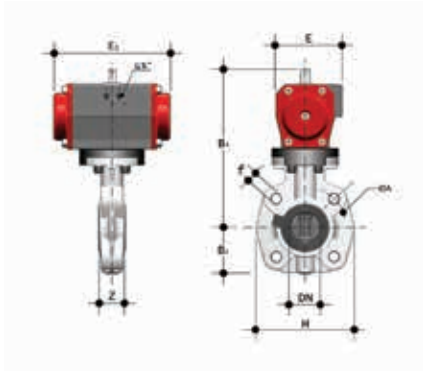

FKOM/CP NO LUG ISO-DIN DN 65

LUG ISO-DIN version butterfly valve with pneumatic actuator Normally Open function

d	DN	PN	B ₂	H	Z	ΦA	f	U	B ₄	E	E ₁	g	EPDM Code	FKM Code
75	65	10	80	165	46	145	M16	4	239	94	210	4700	FKOLMNO075E	FKOLMNO075F

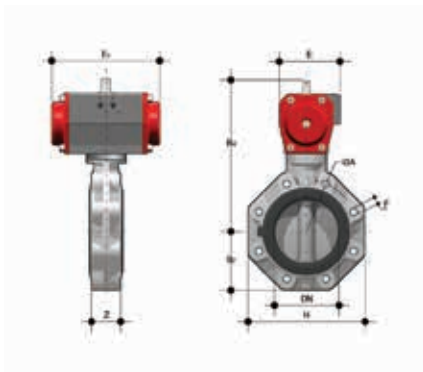

FKOM/CP NO LUG ISO-DIN DN 80-200

LUG ISO-DIN version butterfly valve with pneumatic actuator Normally Open function

d	DN	PN	B ₂	H	Z	ΦA	f	U	B ₄	E	E ₁	g	EPDM Code	FKM Code
90	80	10	93	185	49	160	M16	12	263	104	228	6900	FKOLMNO090E	FKOLMNO075F
110	100	10	107	211	56	180	M16	8	292	120	280	9250	FKOLMNO110E	FKOLMNO090F
140	125	10	120	240	64	210	M16	8	339	134	310	14350	FKOLMNO140E	FKOLMNO110F
160	150	10	134	268	70	240	M20	8	352	134	310	15100	FKOLMNO160E	FKOLMNO140F
225	200	10	161	323	71	295	M20	8	473	176	462	36800	FKOLMNO225E	FKOLMNO160F

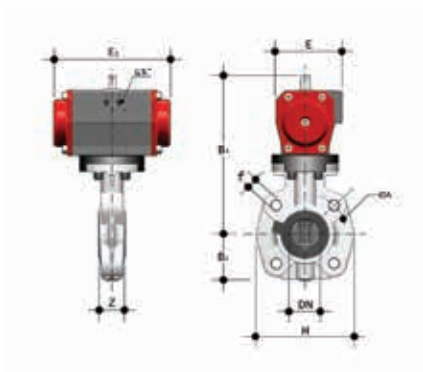

FKOM/CP DA LUG ANSI DN 65

LUG ANSI version butterfly valve with pneumatic actuator. Double-Acting function

d	DN	PN	B ₂	H	Z	ΦA	f	U	B ₂	E	E ₁	g	EPDM Code	FKM Code
2 1/2	65	10	80	165	46	136.7	5/8"	4	222	86	155	2900	FKOALMDA212E	FKOALMDA212F

DIMENSIONS

FK/CP DN 40÷400 PP-H

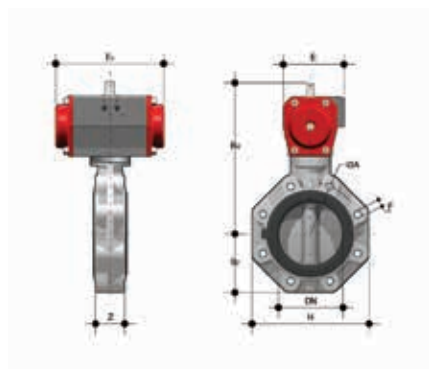

FKOM/CP DA LUG ANSI DN 80-200

LUG ANSI version butterfly valve with pneumatic actuator. Double-Acting function

d	DN	PN	B ₂	H	Z	ΦA	f	U	B ₄	E	E ₁	g	EPDM Code	FKM Code
3"	80	10	93	185	49	152.4	5/8"	12	253	94	210	5000	FKOALMDA300E	FKOALMDA300F
4"	100	10	107	211	56	190.5	5/8"	8	110	104	228	6650	FKOALMDA400E	FKOALMDA400F
5"	125	10	120	240	64	215.9	3/4"	8	297	104	228	8250	FKOALMDA500E	FKOALMDA500F
6"	150	10	134	268	70	241.3	3/4"	8	325	120	280	10600	FKOALMDA600E	FKOALMDA600F
8"	200	10	161	323	71	298.4	3/4"	8	399	134	310	16700	FKOALMDA800E	FKOALMDA800F

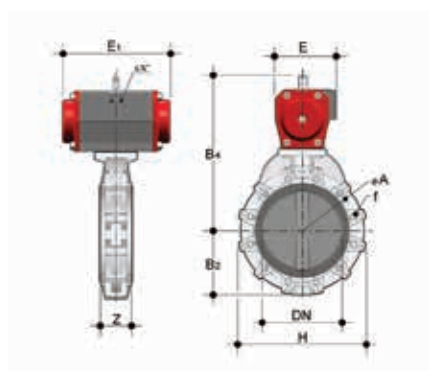

FKOM/CP DA LUG ANSI DN 250-300

LUG ANSI version butterfly valve with pneumatic actuator. Double-Acting function

d	DN	PN	B ₂	H	Z	ΦA	f	U	B ₄	E	E ₁	g	EPDM Code	FKM Code
10"	250	6	210	405	114	362	7/8"	12	453	163	390	32100	FKOALMDA810E	FKOALMDA810F
12"	300	6	245	475	114	431.8	7/8"	12	453	163	390	39000	FKOALMDA812E	FKOALMDA812F

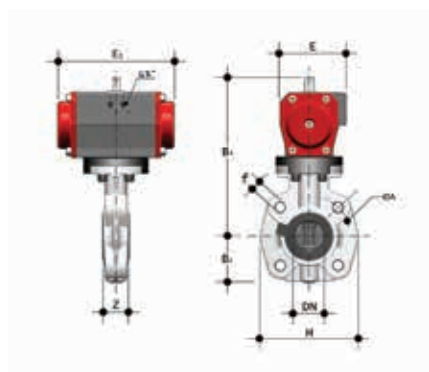

FKOM/CP NC LUG ANSI DN 65

LUG ANSI version butterfly valve with pneumatic actuator. Normally Closed function

d	DN	PN	B ₂	H	Z	ΦA	f	U	B ₄	E	E ₁	g	EPDM Code	FKM Code
2 1/2"	65	10	80	165	46	139.7	5/8"	4	239	94	210	4700	FKOALMNC212E	FKOALMNC212F

DIMENSIONS

FK/CP DN 40÷400 PP-H

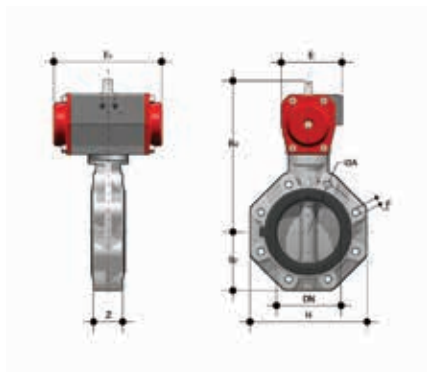

FKOM/CP NC LUG ANSI DN 80-200

LUG ANSI version butterfly valve with pneumatic actuator. Normally Closed function

d	DN	PN	B ₂	H	Z	ΦA	f	U	B ₄	E	E ₁	g	EPDM Code	FKM Code
3"	80	10	93	185	49	152.4	5/8"	12	263	104	228	6900	FKOALMNC300E	FKOALMNC300F
4"	100	10	107	211	56	190.5	5/8"	8	292	120	280	9250	FKOALMNC400E	FKOALMNC400F
5"	125	10	120	240	64	215.9	3/4"	8	339	134	310	14350	FKOALMNC500E	FKOALMNC500F
6"	150	10	134	268	70	241.3	3/4"	8	352	134	310	15100	FKOALMNC600E	FKOALMNC600F
8"	200	10	161	323	71	298.4	3/4"	8	473	176	462	36800	FKOALMNC800E	FKOALMNC800F

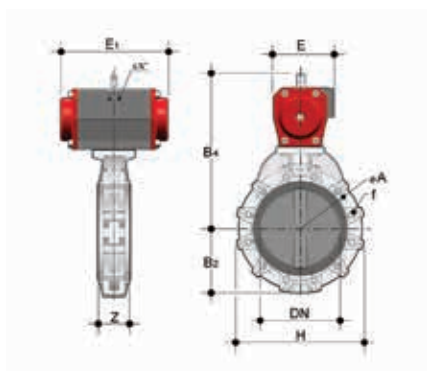

FKOM/CP NC LUG ANSI DN 250-300

LUG ANSI version butterfly valve with pneumatic actuator. Normally Closed function

d	DN	PN	B ₂	H	Z	ΦA	f	U	B ₄	E	E ₁	g	EPDM Code	FKM Code
10"	250	6	210	405	114	362	7/8"	12	538	220	575	69600	FKOALMNC810E	FKOALMNC810F
12"	300	6	245	475	114	431.8	7/8"	12	538	220	575	76500	FKOALMNC812E	FKOALMNC812F

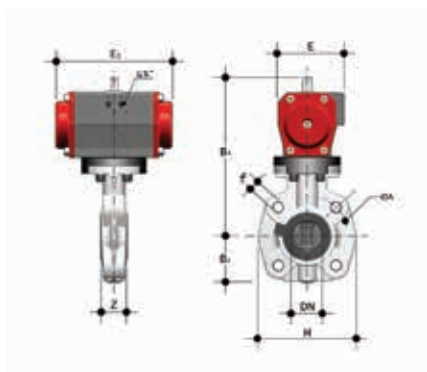

FKOM/CP NO LUG ANSI DN 65

LUG ANSI version butterfly valve with pneumatic actuator. Normally Open function

d	DN	PN	B ₂	H	Z	ΦA	f	U	B ₄	E	E ₁	g	EPDM Code	FKM Code
2 1/2"	65	10	80	165	46	136.7	5/8"	4	239	94	210	4700	FKOALMNO212E	FKOALMNO212F

DIMENSIONS

FK/CP DN 40÷400 PP-H

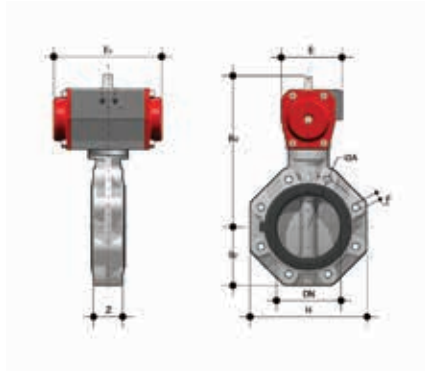

FKOM/CP NO LUG ANSI DN 80-200

LUG ANSI version butterfly valve with pneumatic actuator. Normally Open function

d	DN	PN	B ₂	H	Z	ΦA	f	U	B ₄	E	E ₁	g	EPDM Code	FKM Code
3"	80	10	93	185	49	152.4	5/8"	12	263	104	228	6900	FKOALMNO300E	FKOALMNO300F
4"	100	10	107	211	56	190.5	5/8"	8	292	120	280	9250	FKOALMNO400E	FKOALMNO400F
5"	125	10	120	240	64	215.9	3/4"	8	339	134	310	14350	FKOALMNO500E	FKOALMNO500F
6"	150	10	134	268	70	241.3	3/4"	8	352	134	310	15100	FKOALMNO600E	FKOALMNO600F
8"	200	10	161	323	71	298.4	3/4"	8	473	176	462	36800	FKOALMNO800E	FKOALMNO800F

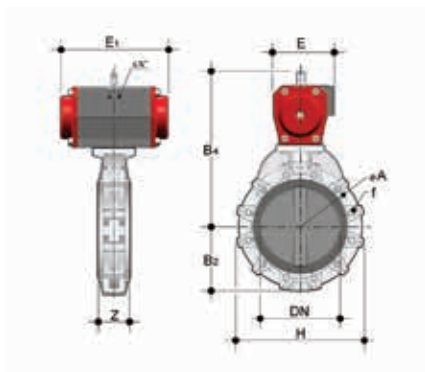

FKOM/CP NO LUG ANSI DN 250-300

LUG ANSI version butterfly valve with pneumatic actuator. Normally Open function

d	DN	PN	B ₂	H	Z	ΦA	f	U	B ₄	E	E ₁	g	EPDM Code	FKM Code
10"	250	6	210	405	114	362	7/8"	12	538	220	575	69600	FKOALMNO810E	FKOALMNO810F
12"	300	6	245	475	114	431.8	7/8"	12	538	220	575	76500	FKOALMNO812E	FKOALMNO812F

DIMENSIONS

FK/CP DN 40÷400 PVDF

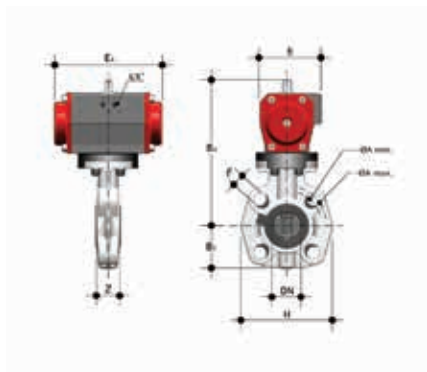

FKOF/CP DA DN 40-65

Butterfly valve with pneumatic actuator, Double-Acting function

d	DN	PN	B ₂	H	Z	A _{min}	A _{max}	f	U	B ₄	E	E ₁	g	FKM Code
50-1 1/2"	40	16	60	132	33	99	109	19	4	209	86	155	2274	FKOFDA050F
63-2"	50	16	70	147	43	115	125.5	19	4	215	86	155	2454	FKOFDA063F
75-2 1/2"	65	10	80	165	46	128	144	19	4	222	86	155	2700	FKOFDA075F



FKOF/CP DA DN 80-200

Butterfly valve with pneumatic actuator, Double-Acting function

d	DN	PN	B ₂	H	Z	A _{min}	A _{max}	f	U	B ₄	E	E ₁	g	FKM Code
90-3"	80	10	93	185	49	145	160	19	12	253	94	210	4450	FKOFDA090F
110-4"	100	10	107	211	56	165	190	19	8	110	104	228	6100	FKOFDA110F
140-5"	125	10	120	240	64	204	215	23	8	297	104	228	6950	FKOFDA140F
160-6"	150	10	134	268	70	230	242	23	8	325	120	280	9350	FKOFDA160F
225-8"	200	10	161	323	71	280	298	23	8	399	134	310	15500	FKOFDA225F

DIMENSIONS

FK/CP DN 40÷400 PVDF

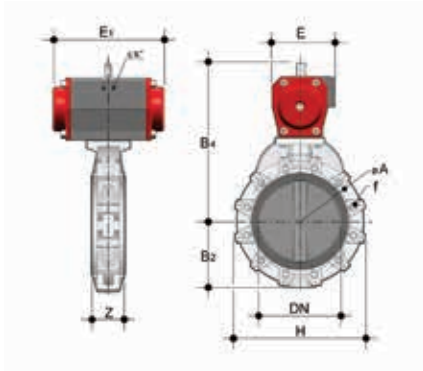

FKOF/CP DA DN 250-300

Butterfly valve with pneumatic actuator, Double-Acting function

d	DN	PN	B ₂	H	Z	ΦA	f	U	B ₄	E	E ₁	g	FKM Code
250/280	*250	10	210	405	114	350	22	12	453	163	390	28500	FKOFDA280F
315	*300	8	245	475	114	400	22	12	510	163	390	36500	FKOFDA315F
10"	**250	10	210	405	114	362	25.4	12	453	163	390	28500	FKOAFDA810F
12"	**300	8	245	475	114	432	25.4	12	510	163	390	36500	FKOAFDA812F

*ISO-DIN
**ANSI B16.5 cl.150

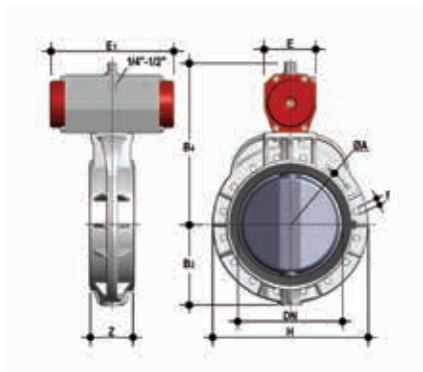

FKOF/CP DA DN 350-400

Butterfly valve with pneumatic actuator, Double-Acting function

d	DN	PN	B ₂	H	Z	ΦA	f	U	B ₄	E	E ₁	g	FKM Code
355	*350	7	280	530	129	460	22	16	550	196	474	58895	FKOFDA355F
400	*400	6	306	594	169	515	26	16	570	196	474	67795	FKOFDA400F
14"	**350	7	280	530	129	476	28.5	12	550	196	474	58895	FKOAFDA814F
16"	**400	6	306	594	169	540	28.5	16	570	196	474	67795	FKOAFDA816F

*ISO-DIN
**ANSI B16.5 cl.150

DIMENSIONS

FK/CP DN 40÷400 PVDF

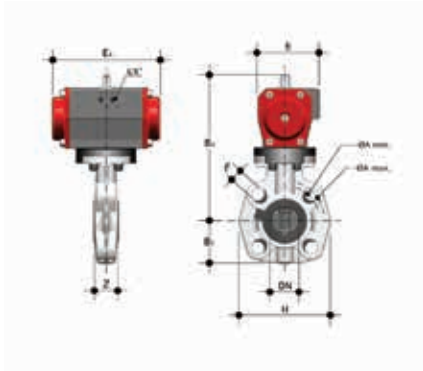

FKOF/CP NC DN 40-65

Butterfly valve with pneumatic actuator, Normally Closed function

d	DN	PN	B ₂	H	Z	A _{min}	A _{max}	f	U	B ₄	E	E ₁	g	FKM Code
50-1 1/2"	40	16	60	132	33	99	109	19	4	209	86	155	2470	FKOFNC050F
63-2"	50	16	70	147	43	115	125.5	19	4	232	94	210	4220	FKOFNC063F
75-2 1/2"	65	10	80	165	46	128	144	19	4	239	94	210	4500	FKOFNC075F

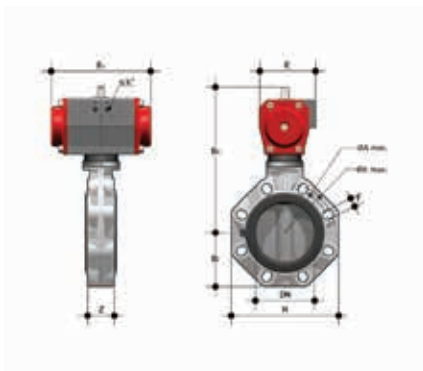

FKOF/CP NC DN 80-200

Butterfly valve with pneumatic actuator, Normally Closed function

d	DN	PN	B ₂	H	Z	A _{min}	A _{max}	f	U	B ₄	E	E ₁	g	FKM Code
90-3"	80	10	93	185	49	145	160	19	12	263	104	228	6350	FKOFNC090F
110-4"	100	10	107	211	56	165	190	19	8	292	120	280	8700	FKOFNC110F
140-5"	125	10	120	240	64	204	215	23	8	339	134	310	13050	FKOFNC140F
160-6"	150	10	134	268	70	230	242	23	8	352	134	310	13850	FKOFNC160F
225-8"	200	10	161	323	71	280	298	23	8	473	176	462	35600	FKOFNC225F

DIMENSIONS

FK/CP DN 40÷400 PVDF

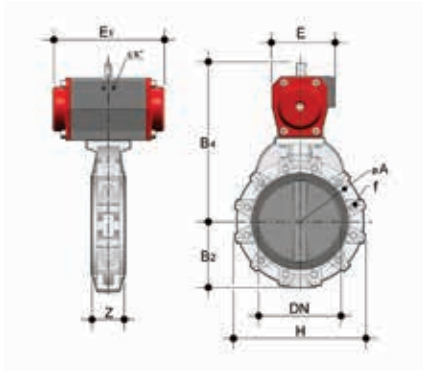

FKOF/CP NC DN 250-300

Butterfly valve with pneumatic actuator, Normally Closed function

d	DN	PN	B ₂	H	Z	ΦA	f	U	B ₄	E	E ₁	g	FKM Code
250/280	*250	10	210	405	114	350	22	12	538	220	575	66000	FKOFNC280F
315	*300	8	245	475	114	400	22	12	595	220	575	74000	FKOFNC315F
10"	**250	10	210	405	114	362	25.4	12	538	220	575	66000	FKOAFNC810F
12"	**300	8	245	475	114	432	25.4	12	595	220	575	74000	FKOAFNC812F

*ISO-DIN
**ANSI B16.5 cl.150

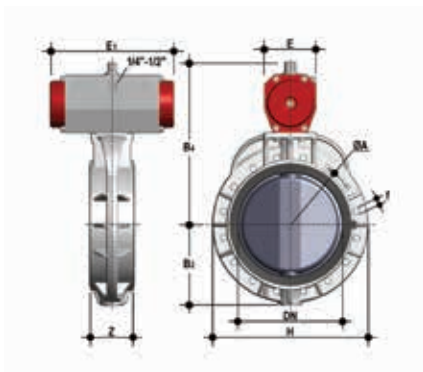

FKOF/CP NC DN 350-400

Butterfly valve with pneumatic actuator, Normally Closed function

d	DN	PN	B ₂	H	Z	ΦA	f	U	B ₄	E	E ₁	g	FKM Code
355	*350	7	280	530	129	460	22	16	628	300	604	102795	FKOFNC355F
400	*400	6	306	594	169	515	26	16	648	300	604	111695	FKOFNC400F
14"	**350	7	280	530	129	476	28.5	12	628	300	604	102795	FKOAFNC814F
16"	**400	6	306	594	169	540	28.5	16	648	300	604	111695	FKOAFNC816F

*ISO-DIN
**ANSI B16.5 cl.150

DIMENSIONS

FK/CP DN 40÷400 PVDF

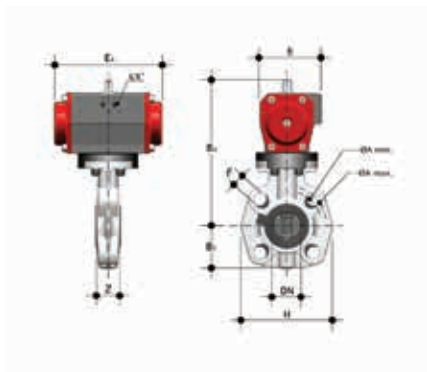

FKOF/CP NO DN 40-65

Butterfly valve with pneumatic actuator, Normally Open function

d	DN	PN	B ₂	H	Z	A _{min}	A _{max}	f	U	B ₄	E	E ₁	g	FKM Code
50-1 1/2"	40	16	60	132	33	99	109	19	4	209	86	155	2470	FKOFNO050F
63-2"	50	16	70	147	43	115	125.5	19	4	232	94	210	4220	FKOFNO063F
75-2 1/2"	65	10	80	165	46	128	144	19	4	239	94	210	4500	FKOFNO075F



FKOF/CP NO DN 80-200

Butterfly valve with pneumatic actuator, Normally Open function

d	DN	PN	B ₂	H	Z	A _{min}	A _{max}	f	U	B ₄	E	E ₁	g	FKM Code
90-3"	80	10	93	185	49	145	160	19	12	263	104	228	6350	FKOFNO090F
110-4"	100	10	107	211	56	165	190	19	8	292	120	280	8700	FKOFNO110F
140-5"	125	10	120	240	64	204	215	23	8	339	134	310	13050	FKOFNO140F
160-6"	150	10	134	268	70	230	242	23	8	352	134	310	13850	FKOFNO160F
225-8"	200	10	161	323	71	280	298	23	8	473	176	462	35600	FKOFNO225F

DIMENSIONS

FK/CP DN 40÷400 PVDF

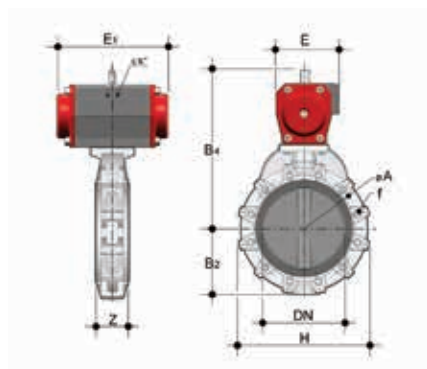

FKOF/CP NO DN 250-300

Butterfly valve with pneumatic actuator, Normally Open function

d	DN	PN	B ₂	H	Z	ΦA	f	U	B ₄	E	E ₁	g	FKM Code
250/280	*250	10	210	405	114	350	22	12	538	220	575	66000	FKOFNO280F
315	*300	8	245	475	114	400	22	12	595	220	575	74000	FKOFNO315F
10"	**250	10	210	405	114	362	25.4	12	538	220	575	66000	FKOAFNO810F
12"	**300	8	245	475	114	432	25.4	12	595	220	575	74000	FKOAFNO812F

*ISO-DIN
**ANSI B16.5 cl.150

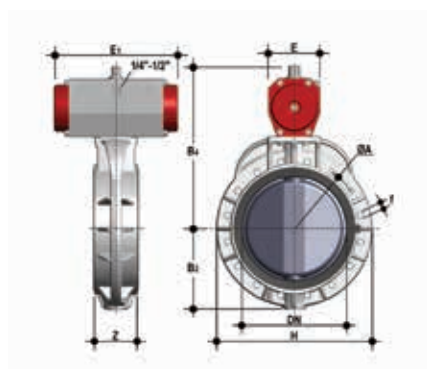

FKOF/CP NO DN 350-400

Butterfly valve with pneumatic actuator, Normally Open function

d	DN	PN	B ₂	H	Z	ΦA	f	U	B ₄	E	E ₁	g	FKM Code
355	*350	7	280	530	129	460	22	16	628	300	604	100395	FKOFNO355F
400	*400	6	306	594	169	515	26	16	648	300	604	109295	FKOFNO400F
14"	**350	7	280	530	129	476	28.5	12	628	300	604	100395	FKOAFNO814F
16"	**400	6	306	594	169	540	28.5	16	648	300	604	109295	FKOAFNO816F

*ISO-DIN
**ANSI B16.5 cl.150

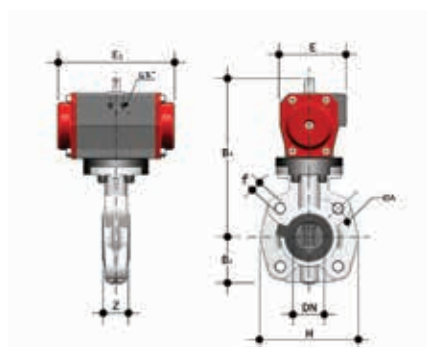

FKOF/CP DA LUG ISO-DIN DN 65

LUG ISO-DIN version butterfly valve with pneumatic actuator Double-Acting function

d	DN	PN	B ₂	H	Z	ΦA	f	U	B ₄	E	E ₁	g	FKM Code
75	65	10	80	165	46	145	M16	4	222	86	155	3100	FKOLFDA075F

DIMENSIONS

FK/CP DN 40÷400 PVDF

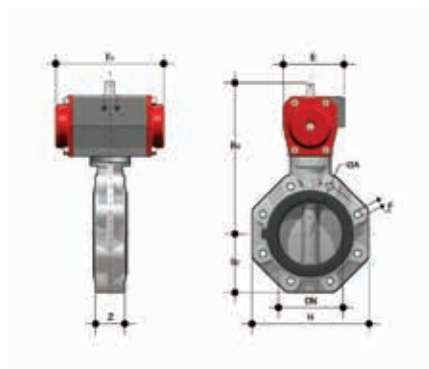

FKOF/CP DA LUG ISO-DIN DN 80-200

LUG ISO-DIN version butterfly valve with pneumatic actuator Double-Acting function

d	DN	PN	B ₂	H	Z	ΦA	f	U	B ₄	E	E ₁	g	FKM Code
90	80	10	93	185	49	160	M16	12	253	94	210	5250	FKOLFDA090F
110	100	10	107	211	56	180	M16	8	110	104	228	6900	FKOLFDA110F
140	125	10	120	240	64	210	M16	8	297	104	228	8550	FKOLFDA140F
160	150	10	134	268	70	240	M20	8	325	120	280	10950	FKOLFDA160F
225	200	10	161	323	71	295	M20	8	399	134	310	17100	FKOLFDA225F

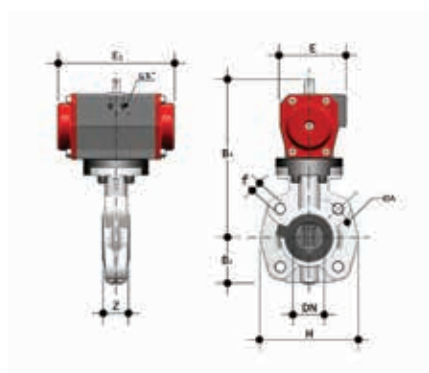

FKOF/CP NC LUG ISO-DIN DN 65

LUG ISO-DIN version butterfly valve with pneumatic actuator Normally Closed function

d	DN	PN	B ₂	H	Z	ΦA	f	U	B ₄	E	E ₁	g	FKM Code
75	65	10	80	165	46	145	M16	4	239	94	210	4900	FKOLFNC075F

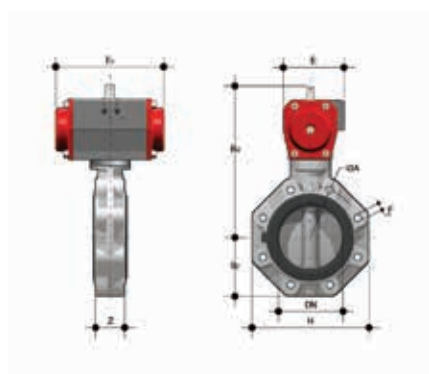

FKOF/CP NC LUG ISO-DIN DN 80-200

LUG ISO-DIN version butterfly valve with pneumatic actuator Normally Closed function

d	DN	PN	B ₂	H	Z	ΦA	f	U	B ₄	E	E ₁	g	FKM Code
90	80	10	93	185	49	160	M16	12	263	104	228	7150	FKOLFNC090F
110	100	10	107	211	56	180	M16	8	292	120	280	9500	FKOLFNC110F
140	125	10	120	240	64	210	M16	8	339	134	310	14650	FKOLFNC140F
160	150	10	134	268	70	240	M20	8	352	134	310	15450	FKOLFNC160F
225	200	10	161	323	71	295	M20	8	473	176	462	37200	FKOLFNC225F

DIMENSIONS

FK/CP DN 40÷400 PVDF

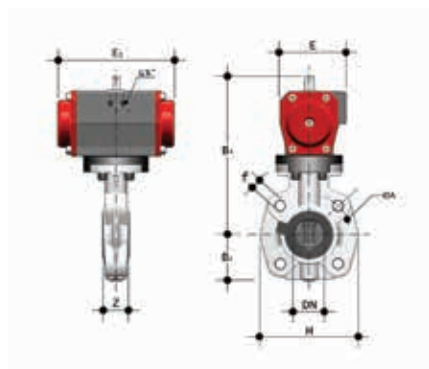

FKOF/CP NO LUG ISO-DIN DN 65

LUG ISO-DIN version butterfly valve with pneumatic actuator Normally Open function

d	DN	PN	B ₂	H	Z	ΦA	f	U	B ₄	E	E ₁	g	FKM Code
75	65	10	80	165	46	145	M16	4	239	94	210	4900	FKOLFNO075F

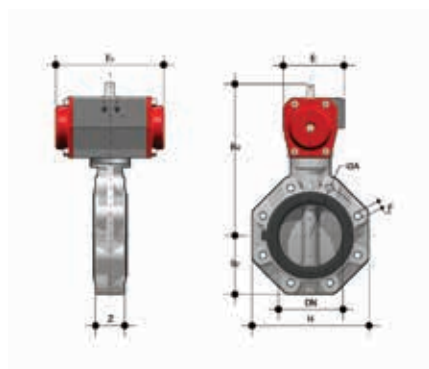

FKOF/CP NO LUG ISO-DIN DN 80-200

LUG ISO-DIN version butterfly valve with pneumatic actuator Normally Open function

d	DN	PN	B ₂	H	Z	ΦA	f	U	B ₄	E	E ₁	g	FKM Code
90	80	10	93	185	49	160	M16	12	263	104	228	7150	FKOLFNO090F
110	100	10	107	211	56	180	M16	8	292	120	280	9500	FKOLFNO110F
140	125	10	120	240	64	210	M16	8	339	134	310	14650	FKOLFNO140F
160	150	10	134	268	70	240	M20	8	352	134	310	15450	FKOLFNO160F
225	200	10	161	323	71	295	M20	8	473	176	462	37200	FKOLFNO225F

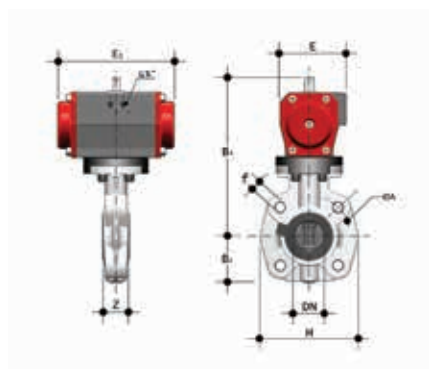

FKOF/CP DA LUG ANSI DN 65

LUG ANSI version butterfly valve with pneumatic actuator. Double-Acting function

d	DN	PN	B ₂	H	Z	ΦA	f	U	B ₄	E	E ₁	g	FKM Code
2 1/2	65	10	80	165	46	139.7	5/8"	4	222	86	155	3100	FKOALFDA212F

DIMENSIONS

FK/CP DN 40÷400 PVDF

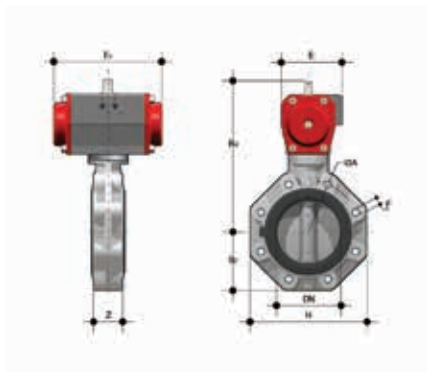

FKOF/CP DA LUG ANSI DN 80-200

LUG ANSI version butterfly valve with pneumatic actuator. Double-Acting function

d	DN	PN	B ₂	H	Z	ΦA	f	U	B ₄	E	E ₁	g	FKM Code
3"	80	10	93	185	49	152.4	5/8"	12	253	94	210	5250	FKOALFDA300F
4"	100	10	107	211	56	190.5	5/8"	8	110	104	228	6900	FKOALFDA400F
5"	125	10	120	240	64	215.9	3/4"	8	297	104	228	8550	FKOALFDA500F
6"	150	10	134	268	70	241.3	3/4"	8	325	120	280	10950	FKOALFDA600F
8"	200	10	161	323	71	298.4	3/4"	8	399	134	310	17100	FKOALFDA800F

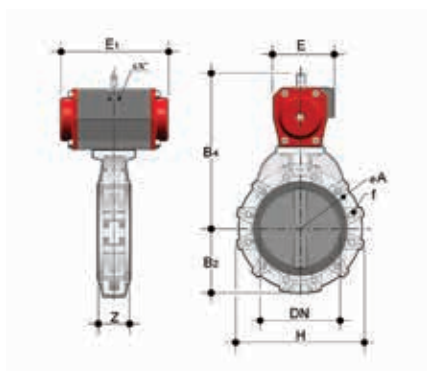

FKOF/CP DA LUG ANSI DN 250-300

LUG ANSI version butterfly valve with pneumatic actuator. Double-Acting function

d	DN	PN	B ₂	H	Z	ΦA	f	U	B ₄	E	E ₁	g	FKM Code
10"	250	6	210	405	114	362	7/8"	12	453	163	390	33300	FKOALFDA810F
12"	300	6	245	475	114	431.8	7/8"	12	453	163	390	41300	FKOALFDA812F

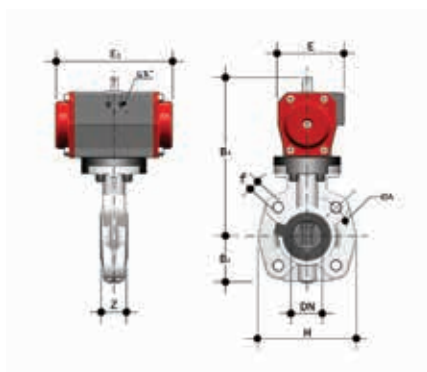

FKOF/CP NC LUG ANSI DN 65

LUG ANSI version butterfly valve with pneumatic actuator. Normally Closed function

d	DN	PN	B ₂	H	Z	ΦA	f	U	B ₄	E	E ₁	g	FKM Code
2 1/2"	65	10	80	165	46	139.7	5/8"	4	239	94	210	4900	FKOALFNC212F

DIMENSIONS

FK/CP DN 40÷400 PVDF

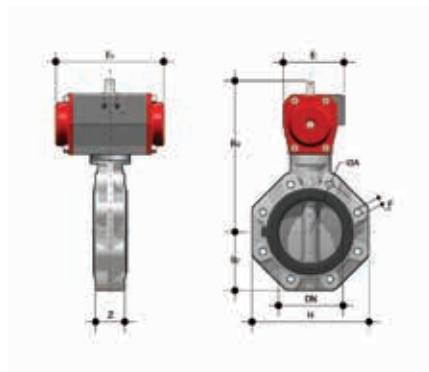

FKOF/CP NC LUG ANSI DN 80-200

LUG ANSI version butterfly valve with pneumatic actuator. Normally Closed function

d	DN	PN	B ₁	H	Z	ΦA	f	U	B ₄	E	E ₁	g	FKM Code
3"	80	10	93	185	49	152.4	5/8"	12	263	104	228	7150	FKOALFNC300F
4"	100	10	107	211	56	190.5	5/8"	8	292	120	280	9500	FKOALFNC400F
5"	125	10	120	240	64	215.9	3/4"	8	339	134	310	14650	FKOALFNC500F
6"	150	10	134	268	70	241.3	3/4"	8	352	134	310	15450	FKOALFNC600F
8"	200	10	161	323	71	298.4	3/4"	8	473	176	462	37200	FKOALFNC800F

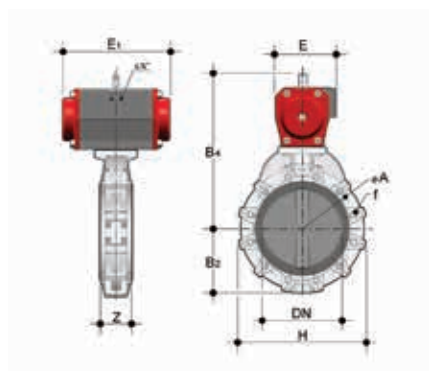

FKOF/CP NC LUG ANSI DN 250-300

LUG ANSI version butterfly valve with pneumatic actuator. Normally Closed function

d	DN	PN	B ₂	H	Z	ΦA	f	U	B ₄	E	E ₁	g	FKM Code
10"	250	6	210	405	114	362	7/8"	12	538	220	575	70800	FKOALFNC810F
12"	300	6	245	475	114	431.8	7/8"	12	538	220	575	78800	FKOALFNC812F

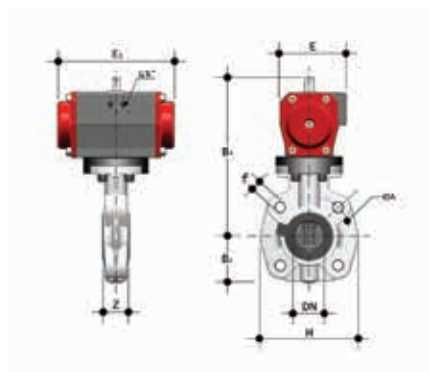

FKOF/CP NO LUG ANSI DN 65

LUG ANSI version butterfly valve with pneumatic actuator. Normally Open function

d	DN	PN	B ₂	H	Z	ΦA	f	U	B ₄	E	E ₁	g	FKM Code
2 1/2"	65	10	80	165	46	139.7	5/8"	4	239	94	210	4900	FKOALFNO212F

DIMENSIONS

FK/CP DN 40÷400 PVDF

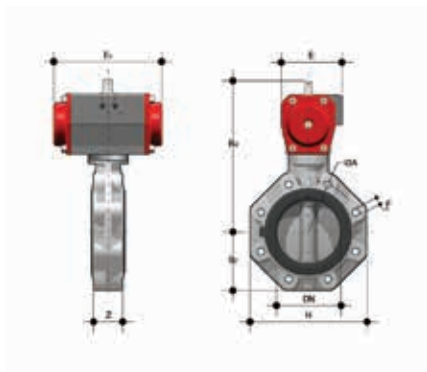

FKOF/CP NO LUG ANSI DN 80-200

LUG ANSI version butterfly valve with pneumatic actuator. Normally Open function

d	DN	PN	B ₂	H	Z	ΦA	f	U	B ₄	E	E ₁	g	FKM Code
3"	80	10	93	185	49	152.4	5/8"	12	263	104	228	7150	FKOALFNO300F
4"	100	10	107	211	56	190.5	5/8"	8	292	120	280	9500	FKOALFNO400F
5"	125	10	120	240	64	215.9	3/4"	8	339	134	310	14650	FKOALFNO500F
6"	150	10	134	268	70	241.3	3/4"	8	352	134	310	15450	FKOALFNO600F
8"	200	10	161	323	71	298.4	3/4"	8	473	176	462	37200	FKOALFNO800F

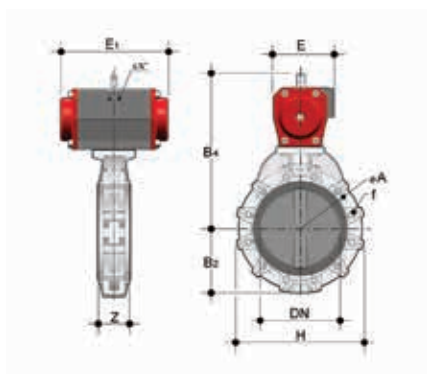

FKOF/CP NO LUG ANSI DN 250-300

LUG ANSI version butterfly valve with pneumatic actuator. Normally Open function

d	DN	PN	B ₂	H	Z	ΦA	f	U	B ₄	E	E ₁	g	FKM Code
10"	250	6	210	405	114	362	7/8"	12	538	220	575	70800	FKOALFNO810F
12"	300	6	245	475	114	431.8	7/8"	12	538	220	575	78800	FKOALFNO812F

COMPONENTS

EXPLODED VIEW DN 40÷50

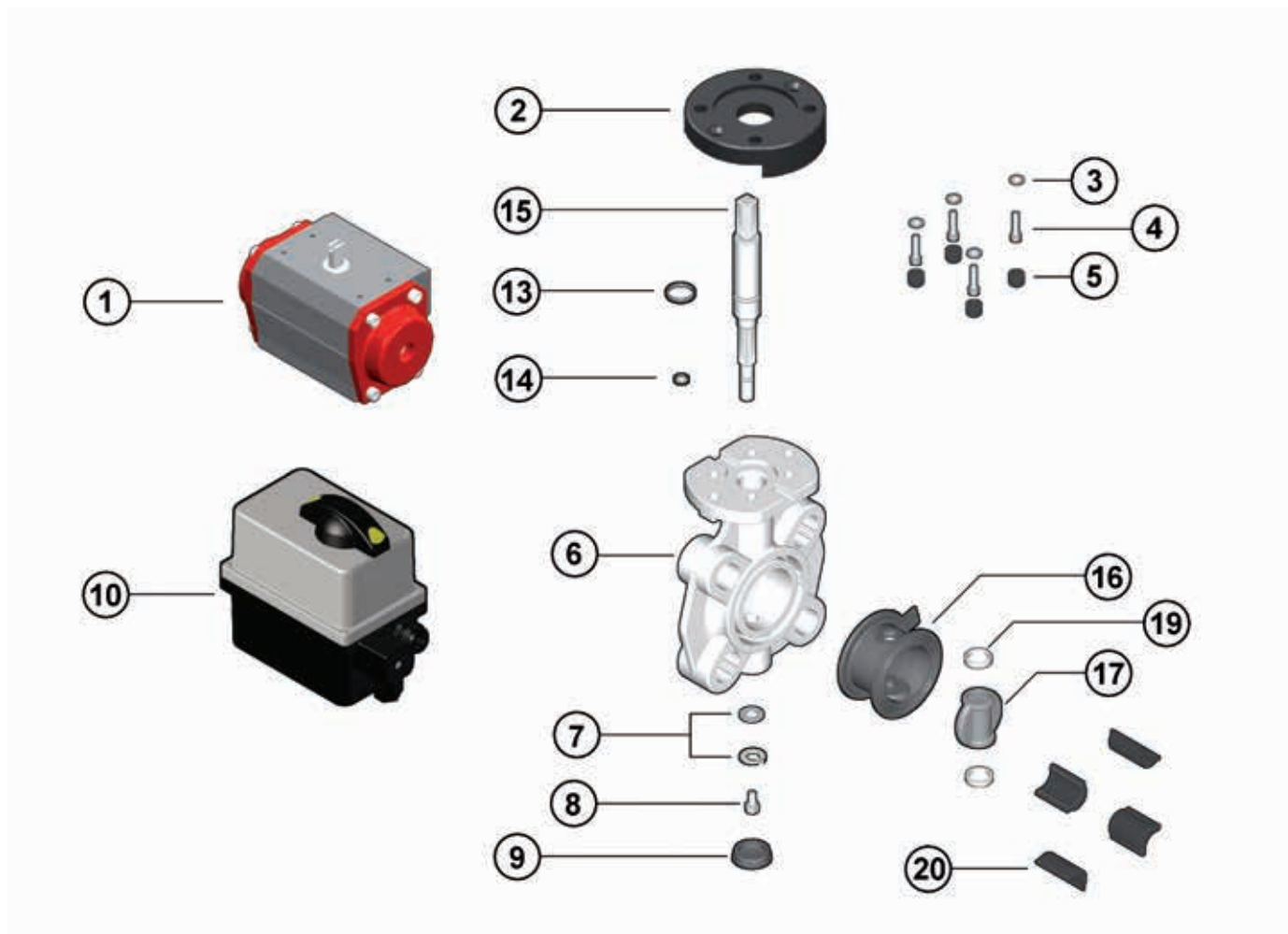

- 1** Pneumatic actuator (Finished aluminium - 1)
- 10** Electric actuator (PA6-Nylon** - 1)
- 2** Actuation flange (PP-GR-1)
- 3** Washer (STAINLESS steel - 4)*
- 4** Fixing screws (stainless steel - 4)*
- 5** Protection plug (PE - 4)*

- 6** Body (PP-GR - 1)
- 7** Washer (Acciaio INOX - 2)
- 8** Fixing screws (stainless steel - 1)
- 9** Protection plug (PE - 1)
- 13** Stem O-Ring (EPDM - FKM - 1)*
- 14** Stem O-Ring (EPDM - FKM - 1)*
- 15** Stem (STAINLESS steel - 1)*

- 16** Primary gasket (EPDM or FKM - 1)*
- 17** Disk (PVC-U/PVC-C/PP-H/PVDF - 1)*
- 19** Anti-friction ring (PTFE - 2)*
- 20** Inserts (ABS - 4)*

* Spare parts

The material the component is made of and the quantity supplied are shown in brackets

EXPLODED VIEW DN 80÷200

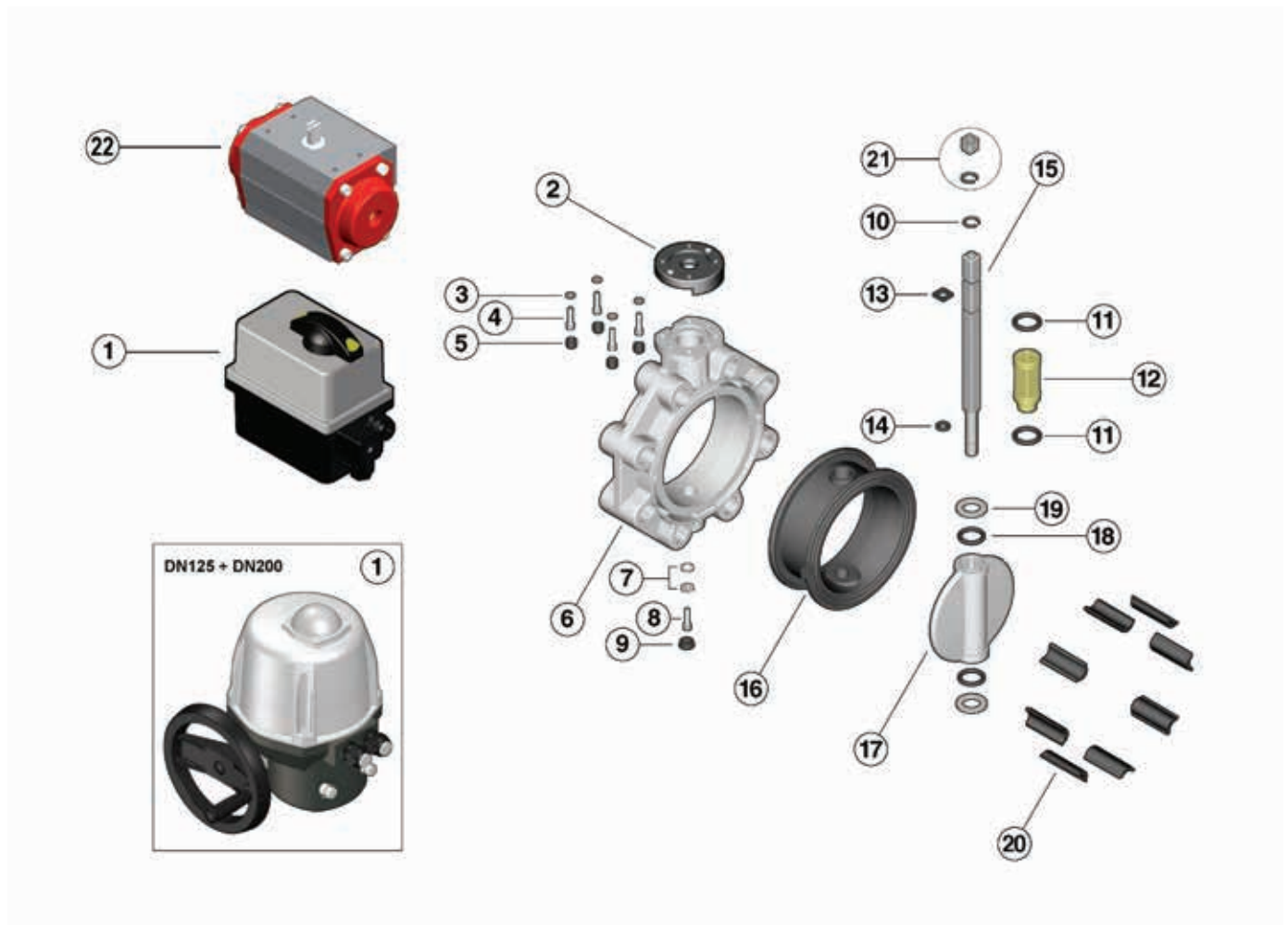

- | | | | | | |
|-----------|--|-----------|-------------------------------------|-----------|--|
| 1 | Electric actuator (PA6-Nylon** - 1)* | 8 | Fixing screws (stainless steel - 1) | 17 | Disk (PVC-U/PVC-C/PP-H/PVDF - 1)* |
| 22 | Pneumatic actuator (Finished aluminium - 1)* | 9 | Protection plug (PE - 1) | 18 | Disk O-Ring (EPDM - FKM - 2)* |
| 2 | Actuation flange (PP-GR-1) | 10 | Seeger ring (STAINLESS steel - 1) | 19 | Anti-friction ring (PTFE - 2)* |
| 3 | Washer (STAINLESS steel - 4)* | 11 | Bush O-Ring (EPDM - FKM - 2)* | 20 | Inserts (ABS - 8)* |
| 4 | Fixing screws (stainless steel - 4)* | 12 | Bush (Nylon - 1) | 21 | Square reduction (STAINLESS steel - 1) |
| 5 | Protection plug (PE - 4)* | 13 | Stem O-Ring (EPDM - FKM - 1)* | | |
| 6 | Body (PP-GR - 1) | 14 | Stem O-Ring (EPDM - FKM - 1)* | | |
| 7 | Washer (Acciaio INOX - 2) | 15 | Stem (STAINLESS steel - 1)* | | |
| | | 16 | Primary gasket (EPDM or FKM - 1)* | | |

* Spare parts

**DN125-200: PA6-Nylon + aluminium

The material the component is made of and the quantity supplied are shown in brackets

EXPLODED VIEW DN 250÷300

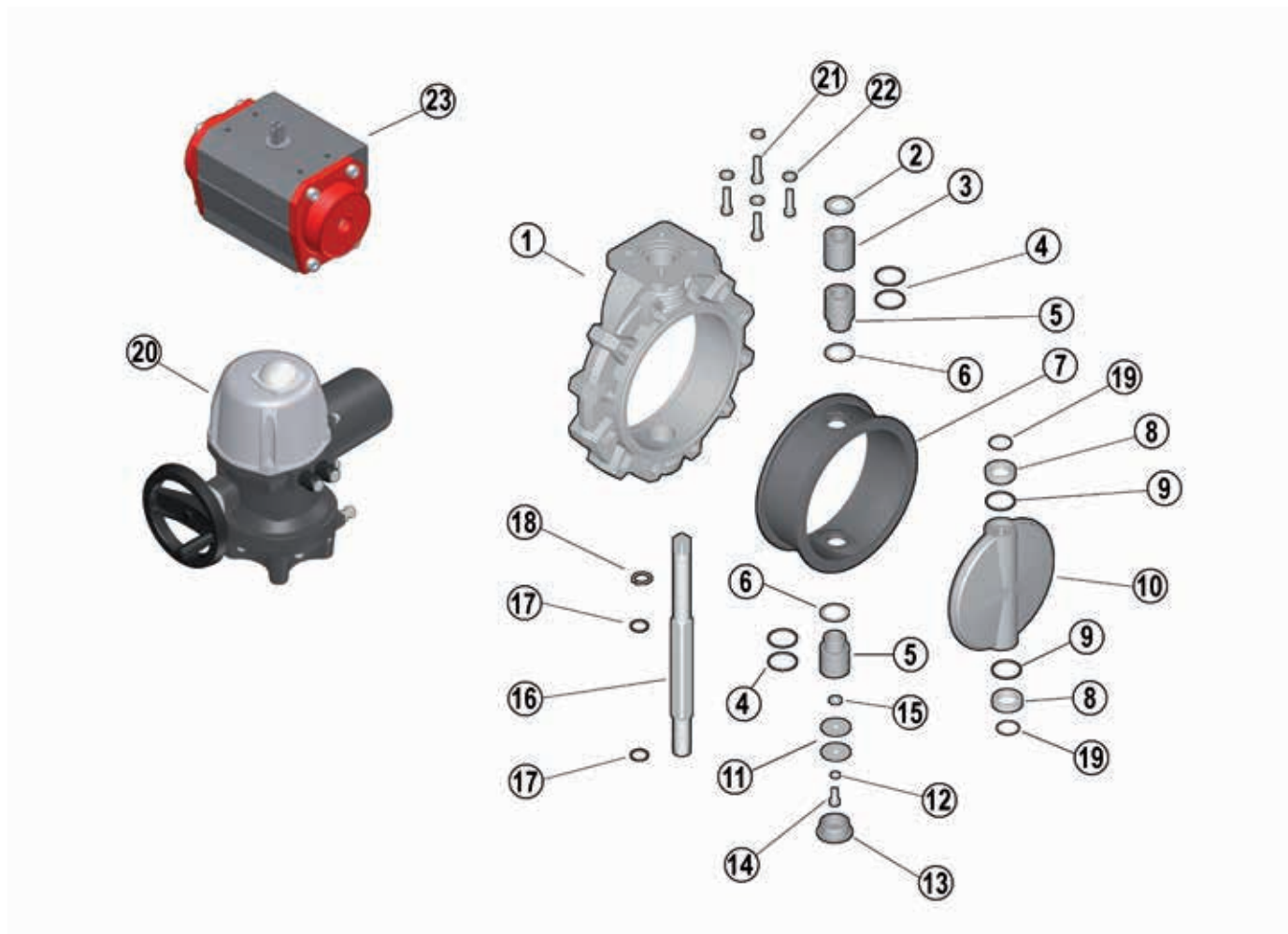

1	Body (PP-GR - 1)	10	Disk (PVC-U/PVC-C/PP-H/PVDF - 1)*	18	Seeger ring (STAINLESS steel - 1)
2	Washer (Acciaio INOX - 1)	11	Washer (Acciaio INOX - 2)	19	O-Ring (EPDM - FKM - 2)*
3	Bush (PP - 1)	12	Washer (Acciaio INOX - 1)	21	Screw (STAINLESS steel - 4)*
4	Bush O-Ring (EPDM - FKM - 4)*	13	Protection plug (PE - 1)	22	Washer (STAINLESS steel - 4)*
5	Bush (PP - 2)	14	Screw (STAINLESS steel - 1)	20	Electric actuator (PA6-Nylon + Aluminium** - 1)*
6	Washer (PTFE - 2)*	15	Washer (Acciaio INOX - 1)	23	Pneumatic actuator (Finished aluminium - 1)
7	Primary gasket (EPDM or FKM - 1)*	16	Stem (Stainless steel 316 - 1)*		
8	Anti-friction ring (PTFE - 2)*	17	Stem O-Ring (EPDM - FKM - 2)*		
9	Disk O-Ring (EPDM - FKM - 2)*				

* Spare parts

** 230V AC: PA6-Nylon+aluminium, 24V AC/DC: aluminium

The material the component is made of and the quantity supplied are shown in brackets

EXPLODED VIEW DN 350÷400



- | | | | | | |
|----------|-----------------------------------|-----------|---|-----------|---|
| 1 | Body (PP-GR - 1) | 10 | Disk (PVC-U / PVC-C / PP-H / PVDF - 1)* | 22 | Washer (Acciaio INOX - 1) |
| 2 | Washer (Acciaio INOX - 1) | 11 | Washer (Acciaio INOX - 1) | 23 | Position indicator (PA - 1) |
| 3 | Bush (PP-H - 1) | 12 | Washer (Acciaio INOX - 1) | 24 | Pneumatic actuator (Finished aluminium - 1) |
| 4 | Bush O-Ring (EPDM or FKM - 6)* | 13 | Protection plug (PE - 1) | 25 | Electric actuator (PA6-Nylon + Aluminium** - 1) |
| 5 | Bush (PP-H - 1) | 14 | Screw (STAINLESS steel - 1) | 26 | Square reduction (STAINLESS steel - 1) |
| 6 | Washer (STAINLESS steel - 2)* | 15 | Stem (Stainless steel 316 - 1)* | 27 | Screw (STAINLESS steel - 4)* |
| 7 | Primary gasket (EPDM or FKM - 1)* | 16 | Stem O-Ring (EPDM or FKM - 2)* | 28 | Washer (STAINLESS steel - 4)* |
| 8 | Anti-friction ring (PTFE - 2) | 17 | Stem O-Ring (EPDM or FKM - 2)* | | |
| 9 | Disk O-Ring (EPDM or FKM - 2)* | 18 | Seeger ring (STAINLESS steel - 1) | | |
| | | 19 | Elastic Pin (STAINLESS steel - 2) | | |

* Spare parts

** 230V AC: PA6-Nylon+aluminium, 24V AC/DC: aluminium

The material the component is made of and the quantity supplied are shown in brackets

DISASSEMBLY

DN 40÷200

- 1) Isolate the valve from the line (release the pressure and empty the pipeline).
- 2) Disconnect the actuator from the compressed air supply and/or power mains.
- 3) Remove the protection plug (5) and screws (4) with the washers (3).
- 4) Remove the actuator (1/10/22) and plate (2) from the body (6).
- 5) Remove the protection plug (9) and screw (8) with the washer (7).
- 6) Extract the stem (15) and disk (17).
- 7) Remove the anti-friction rings (19) and O-rings (18) (DN 65÷200 only).
- 8) Remove the liner (16) from the body (6).
- 9) Remove the Seeger ring (10) and guide bush (12) (DN 65–200 only).
- 10) Remove the seals (11) (DN65–200 only), (13) and (14).

DN 250÷300

- 1) Isolate the valve from the line (release the pressure and empty the pipeline).
- 2) Disconnect the actuator from the compressed air supply and/or power mains.
- 3) Unscrew the screws (21) with their washers (22).
- 4) Remove the actuator (20/23).
- 5) Remove the protection plug (13) and screw (14) with the washers (11-12-15).
- 6) Extract the stem (16) and disk (10).
- 7) Remove the seal (7) from the body (1).
- 8) Remove the Seeger ring (18) and guide bushes (5-3) with washer (2).
- 9) Extract the lower bush (5).
- 10) Remove O-Rings (4) and (17).

DN 350÷400

- 1) Isolate the valve from the line (release the pressure and empty the pipeline).
- 2) Disconnect the actuator from the compressed air supply and/or power mains.
- 3) Unscrew the screws (27) with their washers (28).
- 4) Remove the actuator (24/25).
- 5) Remove the position indicator (23) from the stem (16).
- 6) Remove the protection plug (13) from the body (1).
- 7) Remove the screw (14) and the washers (11) and (22).
- 8) Extract the stem unit (16) from the disk (10).
- 9) Extract the lower bush unit (5) from the lower part of the body (1).
- 10) Remove the disk unit (10) from the body (1).

ASSEMBLY

DN 40÷200

- 1) Place the liner (16) on the body (6).
- 2) Insert the O-Rings (13) and (14) on the stem (15).
- 3) Insert the O-Rings (11) on the guide bush (12) and the bush on the stem. Lock the bush using the Seeger ring (10) (DN 65 – 200 only).
- 4) Position the O-Rings (18) (DN 65–200 only) and then the anti-friction rings (19) on the disk (17) and the disk inside the body, after having lubricated the liner (16).
- 5) Insert the through stem (15) in the body (6) and disk (17).
- 6) Tighten screw (8) with washer (7) and insert the protection plug (9).
- 7) Position the plate (2).
- 8) Position the actuator (1/10/22) and secure it with the screws (4) and washers (3).
- 9) Position the protection plugs (5).
- 10) Reconnect the actuator to the pneumatic and/or power supplies.

DN 250÷300

- 1) Place the liner (7) on the body (1).
- 2) Insert the O-Rings (4) and washer (6) on bushes (5).
- 3) Insert the O-Rings (17) on the stem (16); insert the upper bush (5), bush (3), washer (2) on the stem and secure them with Seeger ring (18).
- 4) Insert the O-rings(19-9) on the anti-friction washers (8).
- 5) Position the washers (8) in the seatings on the disk (10), and the disk inside the body (1) after having lubricated the liner (7).
- 6) Insert the through stem (16) in the body and disk.
- 7) Position the lower bush (5) from below.
- 8) Tighten the screw (14) with washers (11-15) and insert the protection plug (13).
- 9) Position the actuator (20/23) and secure it with the screws (21) and washers (22).
- 10) Reconnect the actuator to the pneumatic and/or power supplies.

DN 350÷400

- 1) Insert the lower bush (5) complete with O-rings (4) on the body (1), subsequently inserting the gland packing washer (6) between the bush and the body.
- 2) Insert the second gland packing washer (6) on the liner (7) and fit these inside the body (1)
- 3) Insert the O-rings (9) and anti-friction rings (8) on the disks (10).
- 4) Lubricate the disk (10) and insert it into the liner (7).
- 5) Insert the upper bush complete with O-rings (3 + -4) on the stem (16) joined to the O-rings (17); insert the washer (2) above the upper bush (3) and insert Seeger ring (18) in the appropriate housing on the stem (16). Insert this unit in the body's upper hole (1).
- 6) Overlap washer (22) on washer (11) equipped with pins (21), and insert this unit on the lower part of the stem (16), fastening it with screw (14) and locking washer (12).
- 7) Insert the protection plug (13) on the body (1).
- 8) Insert the position indicator (23) on the upper part of the stem (16) and square reduction (26).
- 9) Position the actuator (24/25) and secure it with the screws (27) and washers (28).



All operations on equipment under pressure or containing compressed springs must be carried out under safe conditions for the operator.

Note: during mounting operations, it is advisable to lubricate the rubber seals. Mineral oils are not recommended for this task as they react aggressively with EPDM rubber.

INSTALLATION

JOINTS

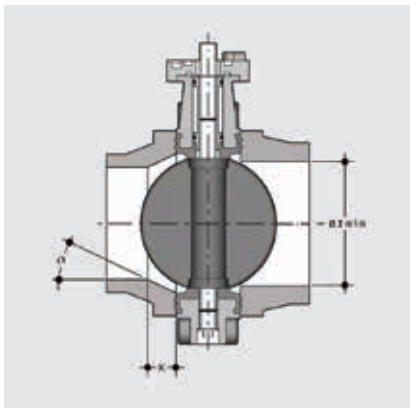

Before proceeding with the installation of the stubs, check that the bore of the fittings has sufficient clearance to allow the valve disk to open correctly. Also check the maximum coupling distance for the liner. Before proceeding with the installation of the FK valve, check that the bore of the stub allows the correct opening of the disk.

DN	l min.
40	25
50	28
65	47
80	64
100	84
125	108
150	134
200	187
250	225
300	280
350	324
400	362

To install on PVC-U collars, check the valve-collar-flange couplings in the following table.

d	DN	50	63	75	90	110	125	140	160	180	200	225	250	280	315	355	400
		40	50	65	80	100	100	125	150	150	200	200	250	250	300	350	400
50	40																
63	50																
75	65																
90	80																
110	100																
140	125						*										
160	150																
225	200									**							
280	250																
315	300																
355	350																
400	400																

Stub with female end for solvent welding according to EN ISO 1452 and DIN 8063- 4

* With special collar d125 DN125 for FE d140 DN125 and flange d140 DN125

** With special collar d200 DN200 for FE d225 DN200 and flange d225 DN200

For the installation of PP-PE stubs, for butt welding a short spigot or electrofusion/
 butt welding a long spigot, check the valve-stub-flange couplings and the K - a
 chamfer dimensions where necessary according to the different SDRs in the
 following table.

	d	DN	50	63	75	90	110	125	140	160	180	200	225	250	280	315	355	400
			40	50	65	80	100	100	125	150	150	200	200	250	250	300	350	400
FK	50	40	■															
	63	50		■														
	75	65			■													
	90	80				■												
	110	100					■	■										
	140	125							■									
	160	150								■	■							
	225	200										■	■					
	280	250												■	■			
	315	300														■		
	355	350																■
	400	400																
SDR		17/17,6										k=26,5 a=20°		k=15,7 a=25°		k=13,3 a=25°	k=45 a=25°	k=55 a=25°
		11										k=35 a=25°	k=40 a=15°	k=32,5 a=25°	k=35 a=25°	k=34,5 a=25°	k=55 a=25°	k=80 a=25°
		7,4			k=10 a=35°	k=15 a=35°		k=20 a=30°	k=35 a=20°	k=15 a=35°	k=40 a=20°	k=35 a=30°	k=55 a=30°	k=35 a=30°	k=65 a=30°			
		33															k=17 a=30°	k=25 a=35°

Short/long spigot stubs according to EN ISO 15494 and DIN 16962/16963 and flange

POSITIONING THE INSERTS

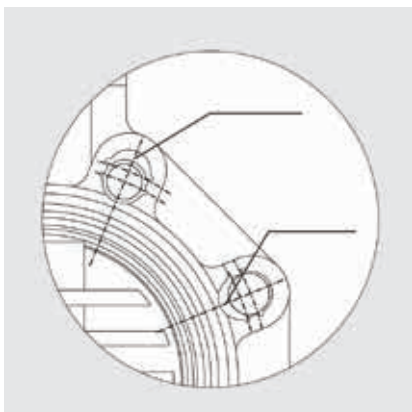

Place the inserts in the holes according to the positions indicated in the table, from the side corresponding to the letters D and DN in order to facilitate the insertion of the stud-bolts and the coupling with the flanges (DN 40 ÷ 200). The self-centring inserts must be inserted in the guides in the slots in the valve body on the side with the writing, with the writing facing upwards, and positioned according to the type of flange drilling, as indicated in the following table:

DN	DIN 2501 PN6 EN 1092-1 BS 4504 PN6 DIN 8063 PN6	DIN 2501 PN10/16 EN 1092-1, BS 4504 PN10/16, DIN 8063 PN10/16, EN ISO 15493, EN ISO 1452	BS 10 table A-D-E Spec D-E	BS 1560 cl.150 ANSI B16.5 cl.150*	JIS B 2220 K5	JIS 2211 K110**
40	Pos. 1	Pos. 2	Pos. 1	Pos. 1	Pos. 1	-
50	Pos. 1	Pos. 2	Pos. 1	-	N/A	-
65	Pos. 1	Pos. 2	Pos. 1	Pos. 2	Pos. 1	Pos. 2
80	Pos. 1	Pos. 2	Pos. 1	Pos. 2	Pos. 1	Pos. 1
100	Pos. 1	Pos. 2	Pos. 1	Pos. 2	Pos. 1	Pos. 1
125	Pos. 1	Pos. 2	Pos. 1	Pos. 2	Pos. 1	-
150	Pos. 1	Pos. 2	Pos. 1	Pos. 2	Pos. 1	Pos. 2
200	Pos. 1	PN 10 Pos. 2	Pos. 2	Pos. 2	Pos. 1	N/A

* DN 50 without inserts

** DN 40, 50, 125 without inserts

POSITIONING THE VALVE

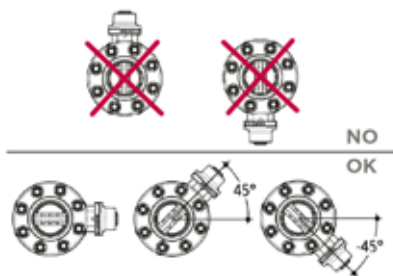

Position the valve between two flanged stubs, taking care to respect the installation tolerances Z. It is advisable to always install the valve with the disk partially closed (it must not exit the body) and avoid any misalignment of the flanges, as this would cause leaks. Where possible comply with the following requirements:

- conveyance of dirty fluids: position the valve with the stem inclined at an angle of 45° to the pipe support plane.
- Conveying fluids with sediment: position the valve with the stem parallel to the pipe support plane.
- Conveying clean fluids: position the valve with the stem perpendicular to the pipe support plane.

TIGHTENING THE STUD-BOLTS

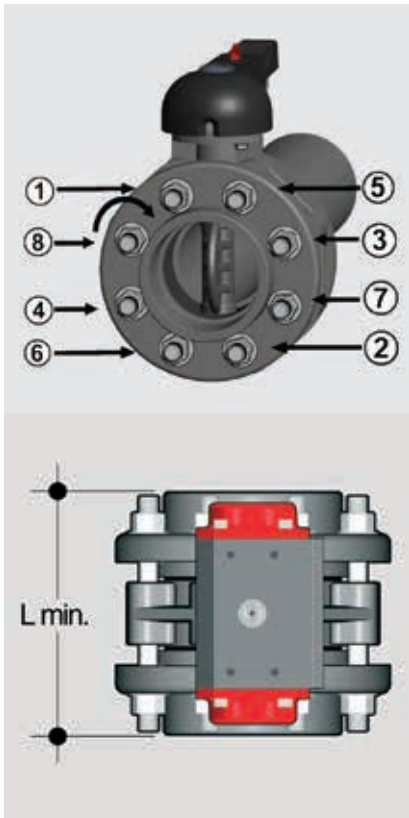

Before tightening the stud-bolts, it is advisable to open the disk in order to prevent damage to the seal. Tighten the stud-bolts in a uniform manner, in the order indicated in the figure, to the nominal operating torque value indicated in the table. The stud-bolts do not need to be excessively tightened in order to produce a perfect hydraulic seal. Overtightening could adversely affect the operating torque of the valve.

DN	L min.	*Nm
40	M16 x150	9
50	M16 x150	12
65	M16 x170	15
80	M16 x180	18
100	M16 x180	20
125	M16 x210	35
150	M20 x 240	40
200	M20 x 260	55
250	M20 x 310	70
300	M20 x 340	70
350	M20 x 360	75
400	M24 x 420	75

* Tightening torques for nuts and bolts on couplings with backing rings.

Values required to obtain the hydraulic test seal (1.5xPN at 20°C) (new or lubricated nuts and bolts)

JIS FLANGED OPTIONS

FK suited for wafer flanged installation in JIS K10 standard available upon request in sizes 10" (DN250), 14" (DN350) and 16" (DN400) and in JIS K5 in sizes 10" (DN250) and 12" (DN300)

WARNINGS

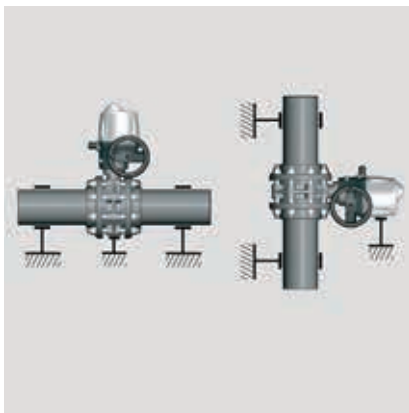

Make sure that the valves installed on the system are suitably supported for their weight.

Always avoid sudden manoeuvres and protect the valve from accidental operations. To this end, it is advisable to install a reduction gear, available on request.



S1 - S2

PVC-U

TWO-WAY RADIAL DISMOUNTING SOLENOID VALVE



S1 – S2 DN 4÷15

The solenoid valve is the ideal solution for applications requiring many rapid actuation cycles and installations in confined spaces. Thanks to the absence of metal parts in contact with the fluid or the external environment, it can also be used in the presence of aggressive fluids. Ideal for use in fertigation benches.

TWO-WAY RADIAL DISMOUNTING SOLENOID VALVE

- 2-Way PVC-U body
- Installation flexibility and ease of maintenance: high-performance solenoid electric actuator designed to exceed 5 million maintenance-free operating cycles
- Adjustable circular section coil with IP65 protection class.
- Integrated override with the possibility of being installed in 3 different positions.
- Lever shutter in EPDM or FKM and lever in stainless steel.
- DIN 43650 electrical connector supplied as standard: includes LED indicator light and rectifier (in the case of an AC coil).

Technical specifications - S1-S3

Construction	2-way solenoid valve
Size range	S12: DN 4-6-8 S22: DN 8-10-15
Temperature range	0 °C ÷ 50 °C
Coupling standards	Solvent welding: EN ISO 1452, EN ISO 493, ISO 727, DIN 8063, ASTM D2467, BS 4346-1, ISO 727-2. Can be coupled to pipes according to ISO 161/1, DIN 8062, ASTM D11785/76, BS 3506, BS 3505 Thread: ISO 228-1, DIN 2999, ASTM D 2467 (NPT), BS 21, BS 10226, ISO 7-1
Valve material	PVC-U
Seal material	EPDM, FKM

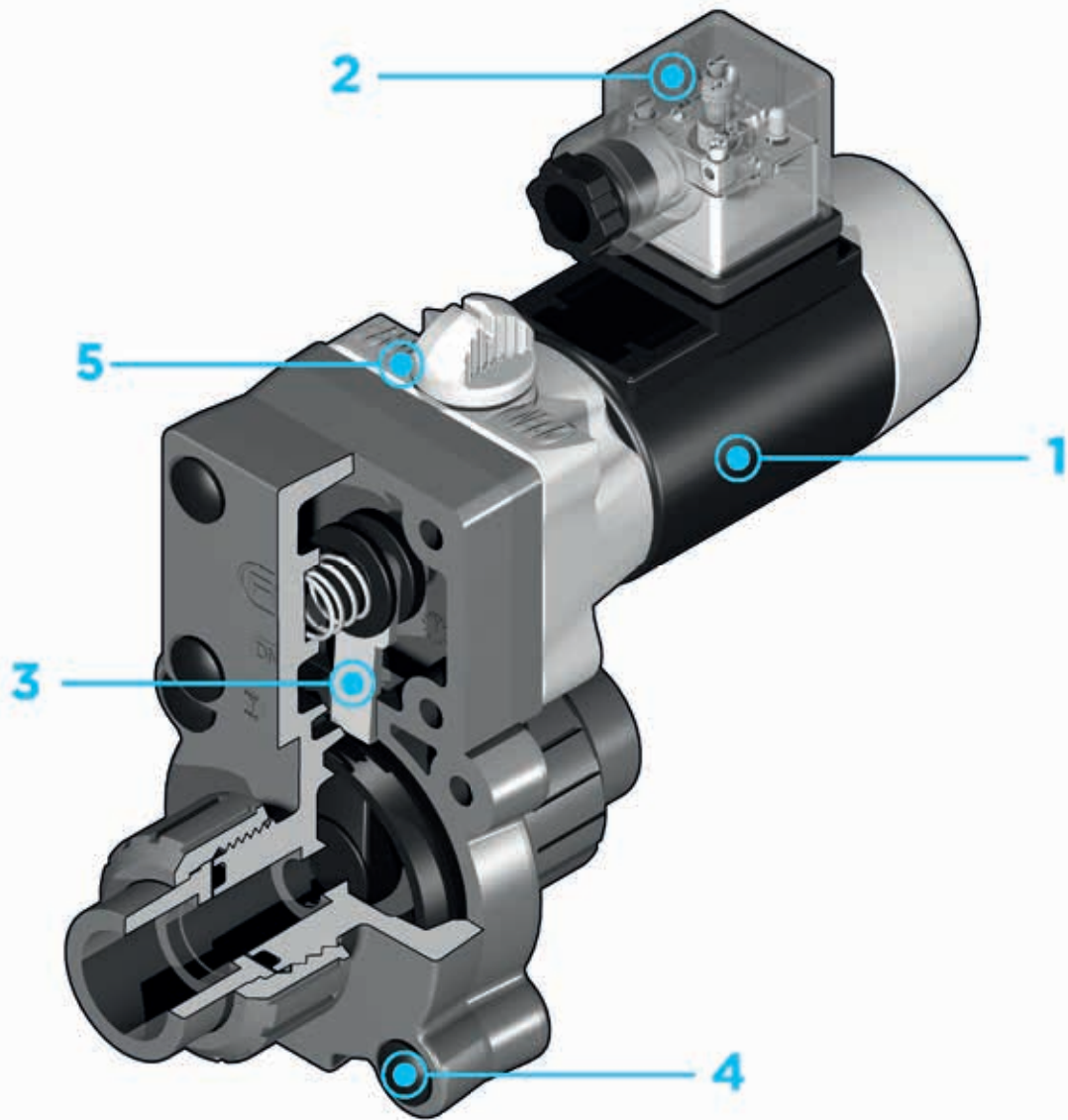

- | | | |
|--|--|---|
| <p>1 Installation flexibility and ease of maintenance: high-performance solenoid electric actuator with internal moving parts designed to exceed 5 million maintenance-free operating cycles Adjustable circular section coil with IP65 protection class.</p> | <p>2 DIN 43650 electrical connector supplied as standard: includes LED indicator light and rectifier (in the case of an AC coil).</p> | <p>4 Suitable for use with aggressive fluids: no metal component in contact with the fluid or the external environment; all the screws are covered by PE protection plugs.</p> |
| | <p>3 Lever shutter in EPDM or FKM and lever in stainless steel.</p> | <p>5 Emergency override.</p> |

CONTROL OPTIONS

2/2 NORMALLY CLOSED

Off

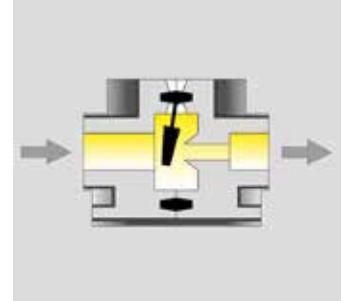
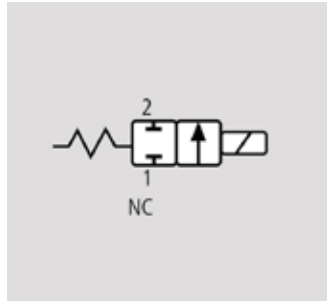
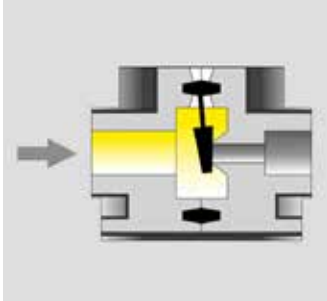

TECHNICAL DATA

TYPE S12 2-WAY VALVE PERFORMANCE

DN	4	6	8
PN	6	4	2
Kv(l/min)*	6.7	12.1	15.3

TYPE S22 2-WAY VALVE PERFORMANCE

DN	8	10	15
PN	6	4	2
Kv(l/min)*	27.5	34.2	58.3

* Q flow of litres per minute of water at a temperature of 20°C that will generate $\Delta p = 1$ bar pressure drop at a certain valve position.

The values shown in the table are calculated with the valve completely open.

GENERAL CHARACTERISTICS

Functional characteristics	lever shutter
S12 and S22 2-way valve control functions	NC
Body material	PVC-U
Seal material	EPDM or FKM.
Maximum environmental temperature	50° C
Maximum working fluid viscosity	38 cSt
Service	100% ED
Close time	~ 20 ms
Open time	~ 20 ms
Alternating current voltages	24V - 110V* - 230V
Frequency	50-60 Hz
Direct current voltages	24 V
Voltage tolerance	± 10%
S12 absorbed power	10 W
S22 absorbed power	20 W
Electrical protection	IP 65
Electrical connection	DIN 43650 connector with LED (1)
Coil thermal class	F (155°C)
Installation	In any position
Coil rotation	over 360°

*Voltage upon request

(1) Connector with internal electronic circuit specific to coil used

S1 – S2 PVC-U

TWO-WAY RADIAL DISMOUNTING SOLENOID VALVE

CODE

Character positions

	1	2	3	4	5	6	7	8	9	10	11	12	13	14
Valve type	de S													
Series	S1	1												
Number of ways	S2	2												
	Two-way		2											
Joint type	ISO female solvent welding (metric)			I										
	BSP female thread (inches)			F										
	ASTM female solvent welding (metric)			A										
	BS female solvent welding (metric)			L										
	NPT female solvent welding (metric)			N										
Material				PVC-U	V									
						DN 4	0	4						
						DN 6	0	6						
						DN 8	0	8						
						DN 10	1	0						
						DN 15	1	5						
Rated diameter														
						d10 metric	1	0						
						d12 metric	1	2						
						d16 metric	1	6						
						d20 metric	2	0						
						BSP - ASTM - BS - NPT - (inches) 1/4"	1	4						
						BSP - ASTM - BS - NPT - (inches) 3/8"	3	8						
						BSP - ASTM - BS - NPT - (inches) 1/2"	1	2						
Dimensions														
										EPDM	E			
Seal material										FKM	F			
										12V	0	1	2	
										24V	0	2	4	
										48V	0	4	8	
										110V	1	1	0	
Coil voltage										230V	2	3	0	
Current												Alternating	A	
												Direct	C	

E.g.: S12IV0616E024C 2-way solenoid valve, S1 series, DN6 d16, ISO unions, PVC-U solvent welding, EPDM seal, 24V DC

DIMENSIONS

S1 - S2 PVC-U

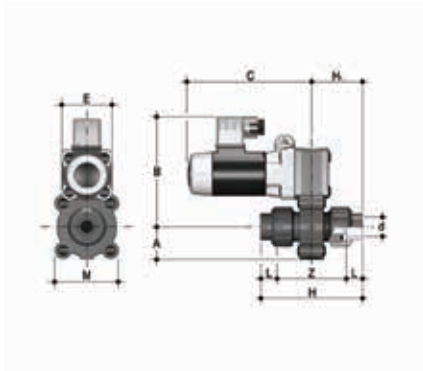

S12IV

2 way solenoid valve with female union ends for solvent welding Function: Normally closed

d	DN	A	B	C	H	H ₁	L	Z	E	M	g	EPDM Code	FKM Code
10	4-6-8	24	100	103	84	42	12	60	42	52	400	See code page	See code page
12	4-6-8	24	100	103	84	42	12	60	42	52	400	See code page	See code page
16	4-6-8	24	100	103	88	44	14	60	42	52	400	See code page	See code page

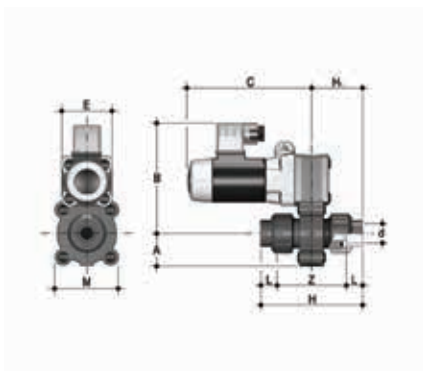

S22IV

2 way solenoid valve with female union ends for solvent welding Function: Normally closed

d	DN	A	B	C	H	H ₁	L	Z	E	M	g	EPDM Code	FKM Code
16	8-10-15	34	115	130	99	50	14	71	54	67	1000	See code page	See code page
20	8-10-15	34	115	130	103	52	16	71	54	67	1000	See code page	See code page

DIMENSIONS

S1 - S2 PVC-U

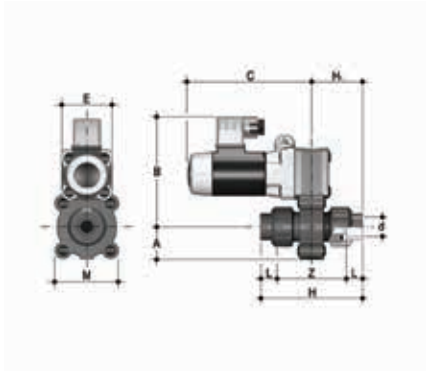

S12AV

2 way solenoid valve with BS female union ends for solvent welding.
Function: Normally closed

d	DN	A	B	C	H	H ₁	L	Z	E	M	g	EPDM Code	FKM Code
1/4"	4-6-8	24	100	103	92	46	16	60	42	52	400	See code page	See code page
3/8"	4-6-8	24	100	103	98	49	19	60	42	52	400	See code page	See code page

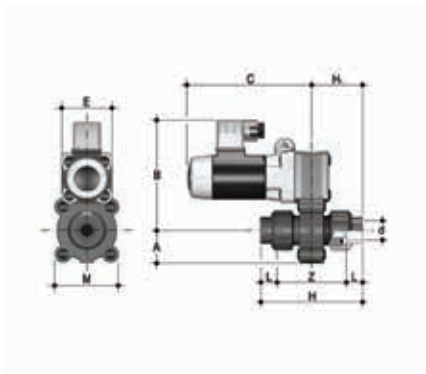

S22AV

2 way solenoid valve with ASTM female union ends for solvent welding.
Function: Normally closed

d	DN	A	B	C	H	H ₁	L	Z	E	M	g	EPDM Code	FKM Code
3/8"	8-10-15	34	115	130	109	55	19	71	54	67	1000	See code page	See code page
1/2"	8-10-15	34	115	130	116	58	22	72	54	67	1000	See code page	See code page

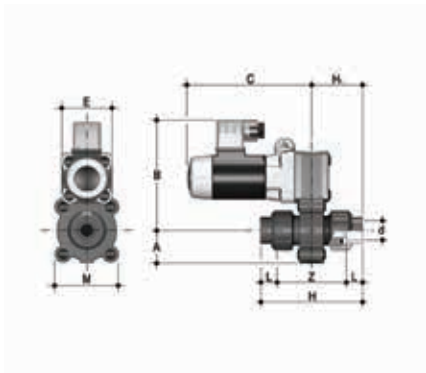

S12LV

2 way solenoid valve with BS female union ends for solvent welding.
Function: Normally closed

d	DN	A	B	C	H	H ₁	L	Z	E	M	g	EPDM Code	FKM Code
3/8"	4-6-8	24	100	103	88	44	14	60	42	52	400	See code page	See code page

DIMENSIONS

S1 - S2 PVC-U



S22LV

2 way solenoid valve with BS female union ends for solvent welding.
Function: Normally closed

d	DN	A	B	C	H	H ₁	L	Z	E	M	g	EPDM Code	FKM Code
3/8"	8-10-15	34	115	130	99	50	14	71	54	67	1000	See code page	See code page
1/2"	8-10-15	34	115	130	104	52	16.5	71	54	67	1000	See code page	See code page



S12FV

2 way solenoid valve with gas cylinder thread female union ends. Function: Normally closed

R	DN	A	B	C	H	H ₁	L	Z	E	M	g	EPDM Code	FKM Code
1/4"	4-6-8	24	100	103	85	42	11	63	42	52	400	See code page	See code page
3/8"	4-6-8	24	100	103	86	43	11.5	63	42	52	400	See code page	See code page

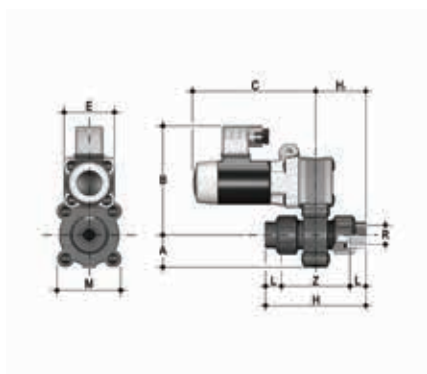

S22FV

2 way solenoid valve with gas cylinder thread female union ends. Function: Normally closed

R	DN	A	B	C	H	H ₁	L	Z	E	M	g	EPDM Code	FKM Code
3/8"	8-10-15	34	115	130	97	48.5	11.5	74	54	67	1000	See code page	See code page
1/2"	8-10-15	34	115	130	105	52.5	15	75	54	67	1000	See code page	See code page

DIMENSIONS

S1 - S2 PVC-U

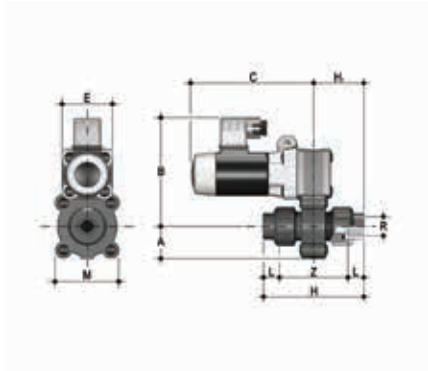

S12NV

2 way solenoid valve with NPT thread female union ends.
Function: Normally closed

R	DN	A	B	C	H	H ₁	L	Z	E	M	g	EPDM Code	FKM Code
1/4"	4-6-8	24	100	103	91	45	15	61	42	52	400	See code page	See code page
3/8"	4-6-8	24	100	103	92	46	16	60	42	52	400	See code page	See code page

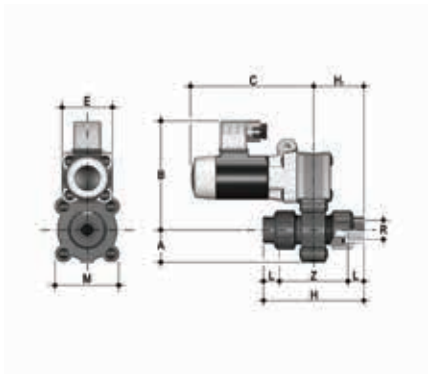

S22NV

2 way solenoid valve with NPT thread female union ends.
Function: Normally closed

R	DN	A	B	C	H	H ₁	L	Z	E	M	g	EPDM Code	FKM Code
3/8"	8-10-15	34	115	130	103	51.5	16	71	54	67	1000	See code page	See code page
1/2"	8-10-15	34	115	130	112	56	20.5	71	54	67	1000	See code page	See code page

COMPONENTS

EXPLODED VIEW

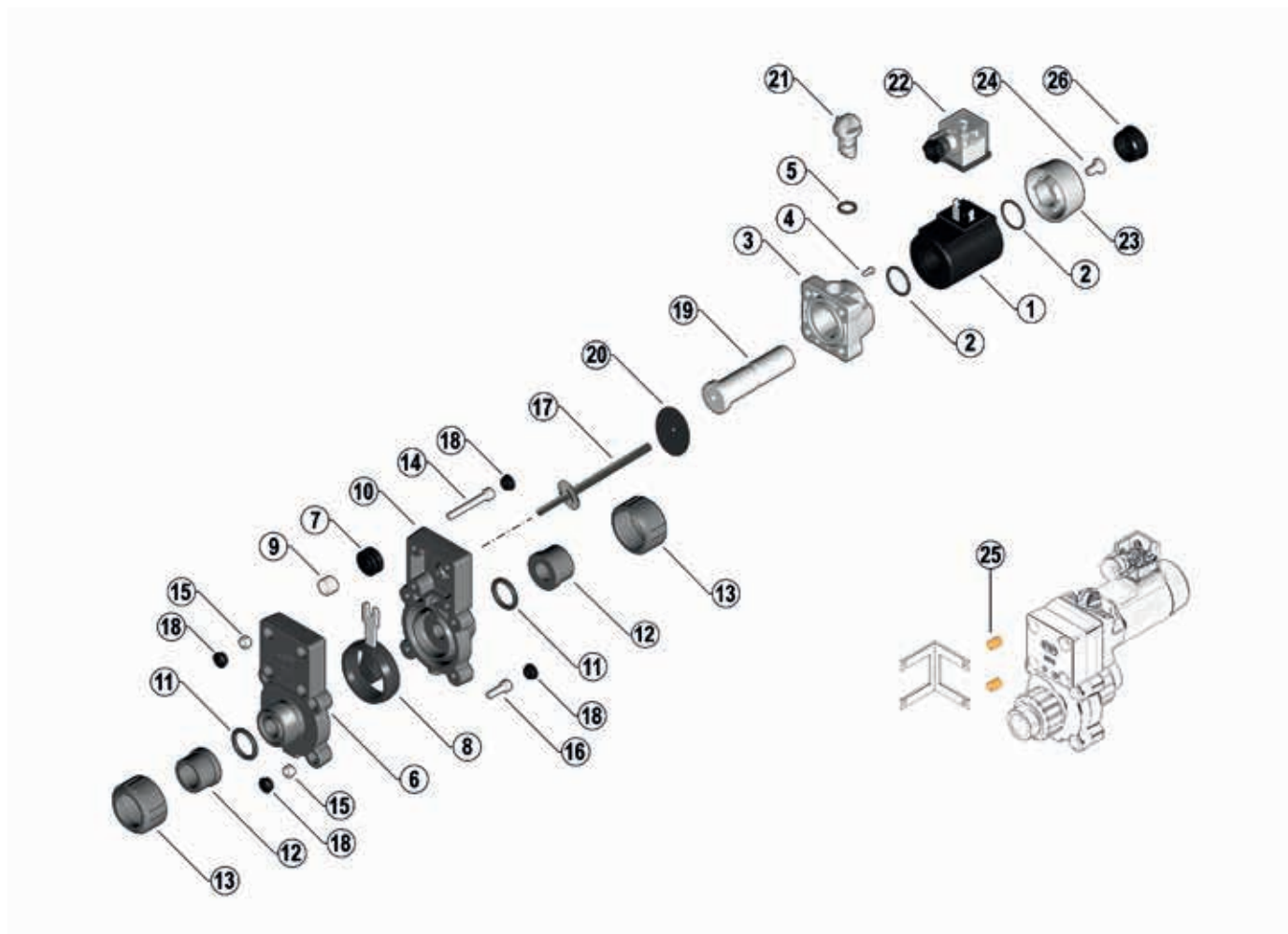

- | | | |
|--|---|--|
| 1 Coil (PA-GR - 1)* | 10 Lower semi-body (PVC-U - 1) | 19 Actuator (STAINLESS steel - 1) |
| 2 O-Ring (EPDM - 2)* | 11 O-Ring (EPDM - FKM - 2)* | 20 Diaphragm seal (VMQ-1) |
| 3 Override housing (PP-GR - 1) | 12 End connector (PVC-U - 2) | 21 Override (PP-GR - 1) |
| 4 Screw (STAINLESS steel - 1) | 13 Union nut (PVC-U - 2)* | 22 Connector (1)* |
| 5 O-Ring (EPDM - 1)* | 14 Fixing screws (stainless steel - 4) | 23 Bonnet Coil (PP-GR - 1) |
| 6 Upper semi-body (PVC-U - 1) | 15 Fixing nuts (stainless steel - 8) | 24 Bonnet fixing screws (stainless steel - 1) |
| 7 Spring return end (PP-GR - 1) | 16 Fixing screws (stainless steel - 4) | 25 Fixing nuts (Brass - 2) |
| 8 Shutter (EPDM-FKM - 1)* | 17 Stem (STAINLESS steel - 1) | 26 Protection plug (PE - 1) |
| 9 Spring return (stainless steel - 1) | 18 Protection plug (PE - 8) | |

* Spare parts

The material the component is made of and the quantity supplied are shown in brackets

DISASSEMBLY

- 1) Unscrew the union nuts (13) and extract the valve from the system and remove the O-rings (11).
- 2) Remove the protection plug (26), unscrew the coil fixing screw (24) and remove the coil bonnet (23).
- 3) Remove the coil (1) and O-rings (2).
- 4) Remove the protection plugs (18) and screws (14).
- 5) Separate the actuator unit from the valve and remove the stem (17) and diaphragm seal (20).
- 6) Unscrew the stop screw (4) and remove the override (21) and O-ring (5). Remove the actuator (19) from the override housing (3).
- 7) Unscrew the screws (16) and separate the two semi-bodies (6 - 10) extracting the shutter (8).
- 8) Remove the spring return (9) from the spring return end (7) and the latter from the shutter (8).

ASSEMBLY

- 1) Insert the spring return end (7) on the shutter rod (8) and spring (9) on the spring return end (7).
- 2) Place the shutter (8) on the upper semi-body (6) being careful that the spring (9) is correctly positioned in its seat.
- 3) Couple the two semi-bodies (6-10) cross tightening the screws (16) according to the recommended torque in the instruction sheet.
- 4) Fully insert the actuator (19) in the override housing (3).
- 5) Place the O-ring (5) on the override (21) and tighten the stop screw (4). Make sure the override freely rotates and move it to the "close" position.
- 6) Insert the stem (17) inside the actuator hole (19), place the seal (20) in the override housing seat.
- 7) Reassemble the actuator on the valve body cross tightening the screws (14) according to the recommended torque in the instruction sheet.
- 8) Reassemble the protection plugs (18), position the coil (1), the coil bonnet (23) and tighten the screw (24) according to the maximum recommended torque in the instruction sheet. Replace the protection plug (26).



Note: during mounting operations, it is advisable to lubricate the rubber seals. Mineral oils are not recommended for this task as they react aggressively with EPDM rubber.

INSTALLATION

- 1) Fluid must be clean without suspended substances. For this reason, we recommend installing an impurity filter upstream from the valve.
- 2) Two or more long bracketing nuts (25) can be used to anchor to the system.
- 3) When electrically connecting the electromagnet, remember that solenoids are powered in direct current (DC) or rectified (for alternating current AC versions). A rectifier that is supplied with the connector must be used for alternating current.

ACCESSORIES

Electrically and pneumatically
actuated valves



Electrically actuated valves

Accessories

Series VKD - TKD - FE - FK - VXE

Accessory reference in valve code

Character position examples

Valve description	Valve code (without accessories)	Reference (last three positions to be added at the end of the valve code)		
Two-way ball valve VKDIV d32 DN25, body in PVC-U and seals in EPDM, ISO fittings for solvent welding female ends, with electric actuator 90-240 V AC and Positioner 4-20 mA / 0-10V	VKDIVEM032E	0	E	-
Butterfly valve FK d90 DN80, with disk in PP-H and seals in FKM, with electric actuator 24V AC/DC with Fail Safe unit	FKOMEL090F	0	F	S
Three-way ball valve 1" 1/2 TKD, body in PVC-U and seals in EPDM, BSP threaded female fittings, ball configuration C3, with electric actuator 90-240V AC and 10W heating element kit	TKDFVEM112E	3	0	H
Only if positions 2 and 3 are used		0		
316 stainless steel stem (for FE - FK butterfly valves only)		X		
C1 ball configuration (for three-way ball valves only)		1		
C2 ball configuration (for three-way ball valves only)		2		
C3 ball configuration (for three-way ball valves only)		3		
Position 1 C4 ball configuration (for three-way ball valves only)		4		
Only if position 3 is used			0	
Positioner 4-20mA / 0-10V			E	
2 auxiliary limit switches kit			M	
4-20 mA position transmitter			T	
100 ohm potentiometer			1	
1000 ohm potentiometer			2	
5000 ohm potentiometer			3	
10000 ohm potentiometer			4	
Position 2 *Fail Safe unit			F	S
Position 3 Heating element kit 10W				H

4-20 mA/0-10V positioner and 4-20 mA transmitter***

Electronic positioner with built-in position transmitter: INPUT 4-20 mA / 0-10V DC. Feedback 4-20 mA / 0-10 V DC

For use with valves in series:	DN	POS.1*	POS.2*	POS.3*
**VKD, TKD	ALL	-	E	-
**VXE	65÷100	-	E	-
**FE, FK	<125	-	E	-
**FE, FK	≥125	-	E	-

*Reference (last three positions to be added at the end of the valve code)

**factory assembled only

*** The actuator model with the same input and power settings but with IP66 and 50% Duty Cycle will be automatically supplied when requesting this accessory on a valve model with IP65 actuator and 30% Duty Cycle

WIRING DIAGRAM

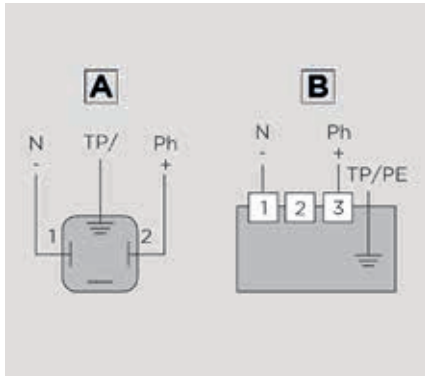

A: VKD/TKD/FE/FK DN < 125

B: FE/FK DN ≥ 125

POWER CONNECTION DIAGRAM

1 Shared

2 Open

3 Closed

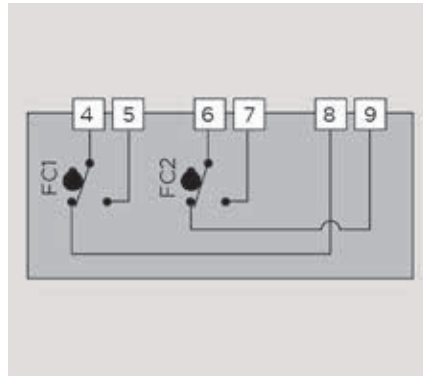

AUXILIARY LIMIT SWITCH CONNECTION DIAGRAM

FC1 Open auxiliary limit switch

FC2 Close auxiliary limit switch

4 Shared FC1

5 Open FC1

6 Shared FC2

7 Open FC2

8 Close FC1

9 Close FC2

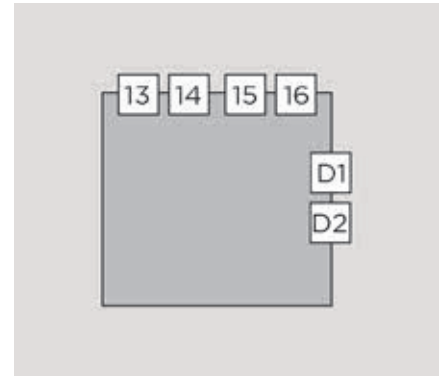

SIGNAL

13 Output +

14 Output -

15 Input -

16 Input +

D1 Error feedback

D2 Error feedback

Technical Data

Board resolution	1°
Input impedance	10 kOhm (0-10V), 100 Ohm (4-20 mA)
Input signal	4-20 mA / 0-10 V
Output signal	4-20 mA / 0-10 V
Error feedback relay capacity	24 V DC - 3 A max
Temperature	-10°, +55°

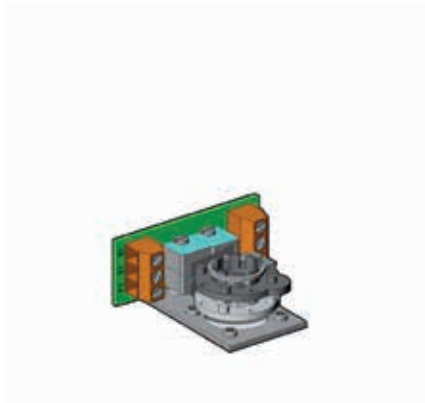

Two auxiliary limit switches

Two limit switches in addition to the standard 2 (four in total)

For use with valves in series:	DN	POS.1*	POS.2*	POS.3*
**VKD, TKD, FE, FK	ALL	-	M	-
**VXE	65÷100	-	M	-

*Reference (last three positions to be added at the end of the valve code)
 ** factory assembled only

WIRING DIAGRAM

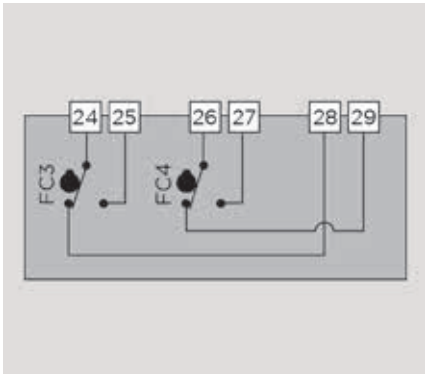

FC3 Auxiliary 3 limit switch
FC4 Auxiliary 4 limit switch

- 24** Shared FC3
- 25** Open FC3
- 26** Shared FC4
- 27** Open FC4
- 28** Close FC3
- 29** Close FC4

Technical Data	
Maximum voltage	240 AC/DC
Empty	Min 10mA - Max 5A

4-20 mA position transmitter

Valve position transmitter via 4-20 mA signal for 90°



For use with valves in series:	DN	POS.1*	POS.2*	POS.3*
**VKD, TKD, FE, FK	ALL	-	T	-
**VXE	65÷100	-	T	-

*Reference (last three positions to be added at the end of the valve code)

** factory assembled only

WIRING DIAGRAM

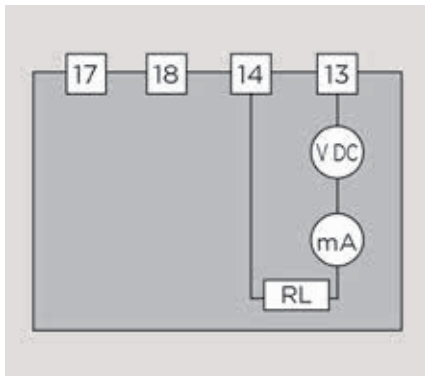

- RL** Load resistance
- 13** Output +
- 14** Output -
- 17** Power (-24V DC)
- 18** Power (+24V DC)

Technical Data	
Reading angle	90°
Tolerance	+/- 10%
Temperature	-10°, +60°
CURRENT OUTPUT	
Signal	4-20mA / 0-20mA*
Resolution	20 microA
Full-scale precision	+/- 5%
Maximum resistive load	800 Ohms
VOLTAGE OUTPUT	
Signal	0-10V*
Resolution	10mV
Full-scale precision	+/- 5%
Minimum resistive load	1 kOhms

*Settable on the actuator board



Potentiometer

Valve position feedback potentiometer with 100, 1000, 5000, 10000 Ohms per 90°

For use with valves in series:	Ohm	POS.1*	POS.2*	POS.3*
**VKD, TKD, VXE, FE, FK	100	-	1	-
**VKD, TKD, VXE, FE, FK	1,000	-	2	-
**VKD, TKD, VXE, FE, FK	5,000	-	3	-
**VKD, TKD, VXE, FE, FK	10,000	-	4	-

*Reference (last three positions to be added at the end of the valve code)

** factory assembled only

WIRING DIAGRAM

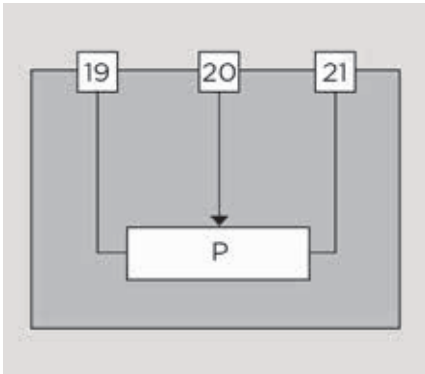

P Potentiometer
19 Shared or -
20 Value reading
21 Phase or +

Technical Data	
Reading angle	90°
Linearity	+/-5%
Tolerance	+/-10%
Max power	1W (240V AC/DC at 125°C)

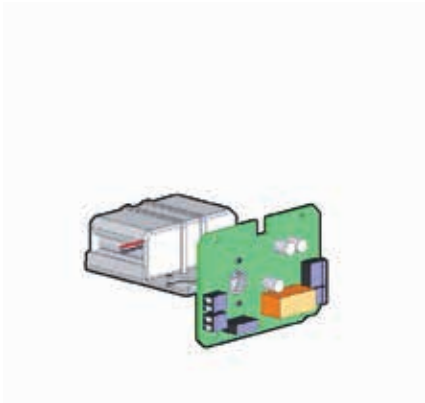

Fail Safe Unit***

Built-in unit for safe return in the event of power outage

For use with valves in series:	DN	POS.1*	POS.2*	POS.3*
**VKD, TKD, VXE, FE	ALL	-	F	S
FK	40÷200	-	F	S

*Reference (last three positions to be added at the end of the valve code)

** factory assembled only

*** The actuator model with the same input and power settings but with IP66 and 50% Duty Cycle will be automatically supplied when requesting this accessory on a valve model with IP65 actuator and 30% Duty Cycle

WIRING DIAGRAM

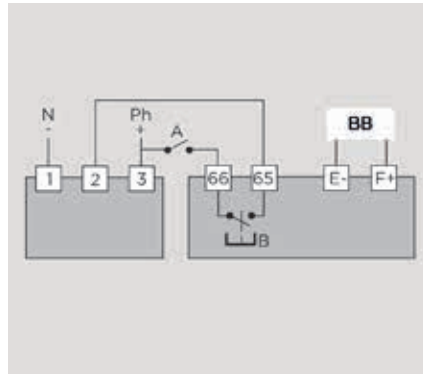
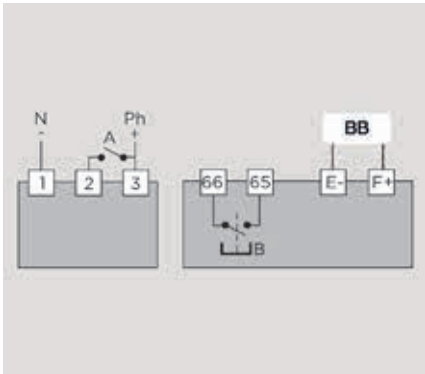

STANDARD CONFIGURATION

- A** Open command
- B** Load feedback relay
- 1** Neutral /-
- 2** Open
- 3** Phase /+
- 65** Relay B contact
- 66** Relay B contact
- BB** Battery block 18V DC

CONFIGURATION WITH LOAD CONTROL

- A** Open command
- B** Load feedback relay
- 1** Neutral /-
- 2** Open
- 3** Phase /+
- 65** Relay B contact
- 66** Relay B contact
- BB** Battery block 18V DC

Technical Data

Voltage	18V DC
Rated current	0.8A
Maximum current	2.4A
Initial load duration	14h max
Load feedback relay capacity	24V DC - 1A max
Temperature	-10°C - 40°C

Anti-condensation heating element***

Heating element kit 10W



For use with valves in series:	DN	POS.1*	POS.2*	POS.3*
**VKD, TKD	ALL	-	-	H
**VXE	65÷100	-	-	H
**FE, FK	40÷100	-	-	H

*Reference (last three positions to be added at the end of the valve code)

** factory assembled only

*** The actuator model with the same input and power settings but with IP66 and 50% Duty Cycle will be automatically supplied when requesting this accessory on a valve model with IP65 actuator and 30% Duty Cycle

WIRING DIAGRAM

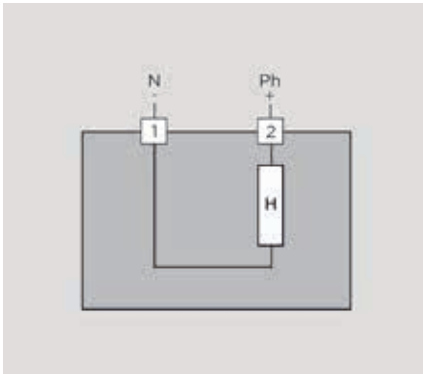

Pneumatically actuated valves

Accessories

Series VKD - TKD - FE - FK - VXE

Accessory reference in valve code

Character position examples

Valve description	Valve code (without accessories)	Reference (last three positions to be added at the end of the valve code)		
Two-way ball valve VKDIV d32 DN25, body in PVC-U and seals in EPDM, female ISO fittings for welding, with pneumatic actuator, Single-acting, Normally closed with electromechanical microswitch box	V K D I V N C 0 3 2 E	0	M	-
Butterfly valve FK d90 DN80, with disk in PP-H and seals in FKM, with pneumatic actuator Single-acting, Normally Open, with smart electro-pneumatic positioner 4-20 mA	F K O M N O 0 9 0 F	0	E	-
Three-way ball valve 1" 1/2 TKD, body in PVC-U and seals in EPDM, BSP threaded female fittings, ball configuration C3, with pneumatic actuator Single-acting, with NAMUR 3-5/2 way pilot solenoid valve 230V AC	T K D F V S E 1 1 2 E	3	0	4
Only if positions 2 and 3 are used		0		
316 stainless steel stem (for FE - FK butterfly valves only)		X		
C1 ball configuration (for three-way ball valves only)		1		
C2 ball configuration (for three-way ball valves only)		2		
C3 ball configuration (for three-way ball valves only)		3		
Position 1 C4 ball configuration (for three-way ball valves only)		4		
Only if position 3 is used			0	
• Optical position indicator			V	
Electromechanical microswitch box			M	
NAMUR inductive microswitch box			N	
PNP10000 ohm inductive microswitch box			I	
Position 2 Smart electro-pneumatic positioner 4-20 mA			E	
3-5/2 way pilot solenoid valve Namur "2EV" 24V DC				1
3-5/2 way pilot solenoid valve Namur "2EV" 24V AC				2
3-5/2 way pilot solenoid valve Namur "2EV" 110V AC				3
Position 3 3-5/2 way pilot solenoid valve Namur "2EV" 230V AC				4



Optical position indicator

Optical position indicator (cannot be assembled with microswitch box)

For use with valves in series:	DN	Code	POS.1*	POS.2*	POS.3*
VKD	ALL	OPI01	-	V	-
VXE	65 ÷ 100	OPI01	-	V	-
FE/FK NC	40 ÷ 100	OPI01	-	V	-
FE/FK NC	125 ÷ 200	OPI02	-	V	-
FE/FK NC	250 ÷ 300	OPI03	-	V	-
FK NC	350 ÷ 400	OPI04	-	V	-
FE/FK DA	40 ÷ 150	OPI01	-	V	-
FE/FK DA	200 ÷ 300	OPI02	-	V	-
FK/DA	350 ÷ 400	OPI03	-	V	-

*Reference (last three positions to be added at the end of the valve code)
 Note: standard on VKD, VXE, FE, FK Normally Open (NO) and on all TKD

NAMUR "2EV" pilot solenoid valve

3-5/2 way pilot solenoid valve, NAMUR for direct assembly on actuator



For use with valves in series:	Voltage	Code	POS.1*	POS.2*	POS.3*
VKD, VXE, TKD, FE, FK	24V DC	2EV024DC	-	-	1
VKD, VXE, TKD, FE, FK	24V AC	2EV024AC	-	-	2
VKD, VXE, TKD, FE, FK	110V AC	2EV110AC	-	-	3
VKD, VXE, TKD, FE, FK	220V AC	2EV220AC	-	-	4

*Reference (last three positions to be added at the end of the valve code)

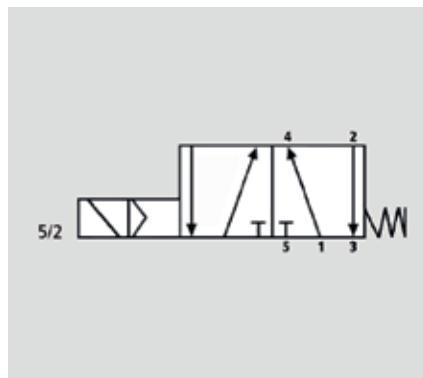
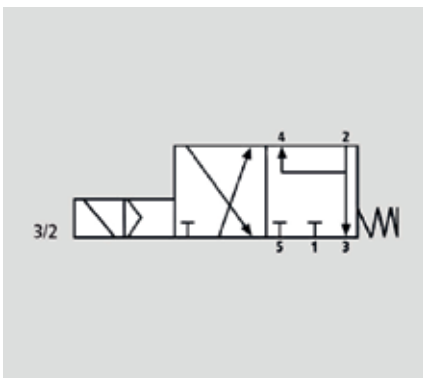

PNEUMATIC CONNECTIONS

- 1 Power
- 3-5 Discharge
- 2 Output (SA)
- 2- Outputs (DA)

Technical Data	
Function	3/2 way (SA) and 5/2 way (DA)
Voltage	24, 110, 220V AC 50-60 Hz, 24V DC
Max absorption	5.5 VA (AC), 4.8W (DC)
Working pressure	2-10 bar
Air flow	950 l/min
Protection class	IP65
Pneumatic connections	G1/4"
Cable inlet	PG9 (6÷9 mm)
Temperature range	-20° ÷ +50 °C
Service	100% ED
Weight	280g
Material	Body: aluminium Gaskets: NBR

Direct assembly as per VDI/VDE 3845
Special and ATEX versions upon request



LSQT limit switch box

New **Technopolymer** limit switch box for quarter turn valves combining easy installation with great versatility of use, even in corrosive environments.

- **Compact design** with threaded cover
- Plastic installation clips and brackets
- Protection class **IP67** or higher guaranteed by safety pin insert
- **Configurable optical indicator** with high visibility yellow arrows
- Label with QR code for digital installation assistance
- Versatility of installation on all quarter turn actuators and FIP manual valves

LSQTMEC

IP67 box containing two electro-mechanical microswitches and configurable optical indicator

For use with valves in series:	DN	Code	POS.1*	POS.2*	POS.3*
VKD, TKD, FE, FK	ALL	LSQTMEC	-	M	-
VXE	65 ÷ 100	LSQTMEC	-	M	-

*Reference (last three positions to be added at the end of the valve code)

WIRING DIAGRAM

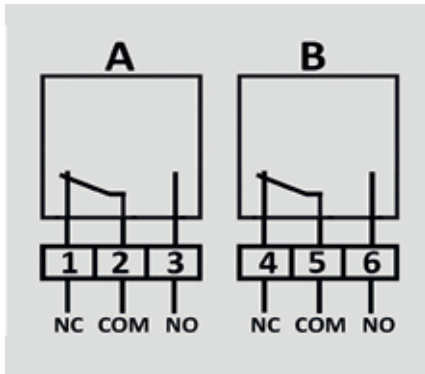

TECHNICAL DATA

Switch type	SPDT, OMRON D3V-16-1C5
Contacts rate	0.3A (250 VDC) - 0.6A (125 VDC) - 10A (250 VAC)
Protection class	IP67 / DIN EN 60529
Temperature range	-10°/+50°C
Cable inlet	1 M20x1.5 / 6-12mm cable gland

LSQTPNP

IP68 box containing two inductive PNP (3 wire) microswitches with configurable optical indicator

For use with valves in series:	DN	Code	POS.1*	POS.2*	POS.3*
VKD, TKD, FE, FK	ALL	LSQTPNP	-	I	-
VXE	65 ÷ 100	LSQTPNP	-	I	-

*Reference (last three positions to be added at the end of the valve code)

Note: for the version with NAMUR inductive microswitches and ATEX certification, contact our technical assistance service.

WIRING DIAGRAM

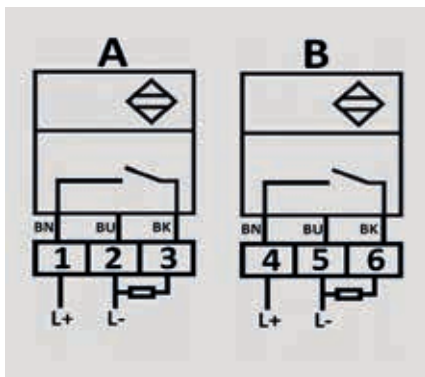

TECHNICAL DATA

Switch type	Inductive PNP 3-wire, P+F NBN4-V3-E2
Voltage	10-30 V DC
Frequency	0-500 Hz
Operating current	0-100mA
No-load current	<=15mA
Protection class	IP68 / DIN EN 60529
Temperature range	-10°/+50°C
Cable inlet	1 M20x1.5 / 6-12mm cable gland

Dimensions common to all versions

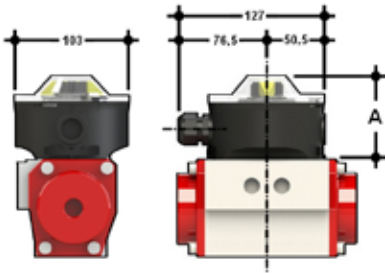

For use with valves in series:	DN	A
VKD	10 ÷ 100	71.5
VXE	65 ÷ 100	71.5
TKD	10 ÷ 50	71.5
FE-FK/CP NC-NO	40 ÷ 100	71.5
FE-FK/CP NC-NO	125 ÷ 400	126.5
FE-FK/CP DA	40 ÷ 150	71.5
FE-FK/CP DA	200 ÷ 400	126.5

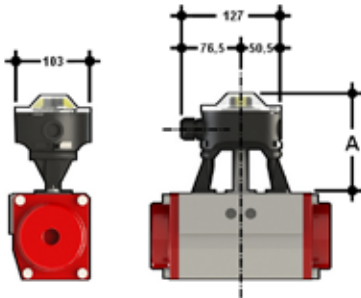

For use with valves in series:	DN	A
VKD	10 ÷ 100	71.5

Electro-pneumatic positioner

Single and Double-acting smart electro-pneumatic positioner with 4 - 20 mA input plus 4-20 mA transmitter



For use with valves in series:	DN	POS.1*	POS.2*	POS.3*
**VKD, VXE, TKD, FE, FK	ALL	-	E	-

*Reference (last three positions to be added at the end of the valve code)
**factory assembled only

Technical Data	
Input signal	4-20mA
Protection class	IP65 / EN 60529
Temperature range	0°C ÷ +60°C
Pneumatic connections	G 1/4"
Maximum supply pressure	7 bar
Air consumption	150 NI/min at 6 bar
Consumption	≤ 3,5W
Material	Body, cover: Painted aluminium
Voltage	24 V DC

Abbreviation Legend

ABS	Acrilonitrile butadiene styrene
b	bolts
c	O-Ring code
d	nominal external diameter of the pipe in mm
DA	double-acting
DN	nominal internal diameter of the pipe in mm
EPDM	Ethylene-Propylene-Diene-Monomer
FKM (FPM)	fluoroelastomer
g	weight in grams
HIPVC	PVC high impact
K	lid key
Kg	weight in kilograms
L	length in metres
MRS	minimum guaranteed value of the breaking strength of the material at 20°C - water - for 50 years' service
n	number of flange holes
NBR	nitrile butadiene rubber
OP	working pressure
P	pipe holder
PA	polyamide
PA-GR	fibreglass reinforced polyamide
PBT	polybutylene terephthalate
PE	polyethylene
PN	nominal pressure in bar (max. operating pressure at 20°C water)
POM	polyoxymethylene
PP-GR	fibreglass reinforced polypropylene
PP-H	polypropylene homopolymer

PPS	Polyphenylene sulphide
PPSU	Polyphenylsulfone
PTFE	polyethrafluorethylene
PVC-C	chlorinated polyvinyl chloride
PVC-U	unplasticized polyvinylchloride
PVDF	polyvinylidene difluoride
R	nominal thread size in inches
s	pipe thickness in mm
SA	single-acting
SDR	standard dimension ratio = d / s
Sp	flange thickness on flanged valvesa
U	number of flange holes for flanged valves

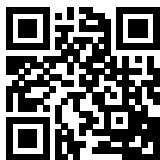

COD. LEVAECTBUTSOLO1



FIP Formatura Iniezione Polimeri

Loc. Pian di Parata, 16015 Casella Genova Italy

Tel. +39 0109621.1 - Fax +39 010 9621.209

info.fip@alixis.com

www.fipnet.com

UNI EN
ISO 9001
QUALITY

UNI EN
ISO 14001
ENVIRONMENTAL
MANAGEMENT

